

**International Standards
and Recommended Practices**



**Annex 6
to the Convention on
International Civil Aviation**

Operation of Aircraft

**Part I
International Commercial
Air Transport — Aeroplanes**

This edition incorporates all amendments adopted by the Council prior to 27 February 2010 and supersedes, on 18 November 2010, all previous editions of Part I of Annex 6.

For information regarding the applicability of the Standards and Recommended Practices, see Foreword.

**Ninth Edition
July 2010**

International Civil Aviation Organization

**International Standards
and Recommended Practices**



**Annex 6
to the Convention on
International Civil Aviation**

Operation of Aircraft

**Part I
International Commercial
Air Transport — Aeroplanes**

This edition incorporates all amendments adopted by the Council prior to 27 February 2010 and supersedes, on 18 November 2010, all previous editions of Part I of Annex 6.

For information regarding the applicability of the Standards and Recommended Practices, see Foreword.

**Ninth Edition
July 2010**

International Civil Aviation Organization

Published in separate English, Arabic, Chinese, French, Russian
and Spanish editions by the
INTERNATIONAL CIVIL AVIATION ORGANIZATION
999 University Street, Montréal, Quebec, Canada H3C 5H7

For ordering information and for a complete listing of sales agents
and booksellers, please go to the ICAO website at www.icao.int

First edition 1969
Eighth edition 2001
Ninth edition 2010

Annex 6, Operation of Aircraft
Part I, International Commercial Air Transport — Aeroplanes
Order Number: AN 6-1
ISBN 978-92-9231-536-8

© ICAO 2010

All rights reserved. No part of this publication may be reproduced, stored in a
retrieval system or transmitted in any form or by any means, without prior
permission in writing from the International Civil Aviation Organization.

AMENDMENTS

Amendments are announced in the supplements to the *Catalogue of ICAO Publications*; the Catalogue and its supplements are available on the ICAO website at www.icao.int. The space below is provided to keep a record of such amendments.

RECORD OF AMENDMENTS AND CORRIGENDA

AMENDMENTS			
No.	Date applicable	Date entered	Entered by
1-34	Incorporated in this edition		
35	15/12/11	—	ICAO
36	15/11/12	—	ICAO

CORRIGENDA			
No.	Date of issue	Date entered	Entered by
1	Did not affect this language version.		
2	10/10/11	—	ICAO

TABLE OF CONTENTS

	<i>Page</i>
Abbreviations and symbols.....	(xi)
Publications	(xiv)
FOREWORD	(xvii)
CHAPTER 1. Definitions	1-1
CHAPTER 2. Applicability.....	2-1
CHAPTER 3. General.....	3-1
3.1 Compliance with laws, regulations and procedures.....	3-1
3.2 Compliance by a foreign operator with laws, regulations and procedures of a State	3-2
3.3 Safety management.....	3-2
3.4 Dangerous goods	3-3
3.5 Use of psychoactive substances	3-4
CHAPTER 4. Flight operations.....	4-1
4.1 Operating facilities.....	4-1
4.2 Operational certification and supervision	4-1
4.3 Flight preparation	4-6
4.4 In-flight procedures	4-13
4.5 Duties of pilot-in-command.....	4-16
4.6 Duties of flight operations officer/flight dispatcher.....	4-16
4.7 Additional requirements for operations by aeroplanes with turbine engines beyond 60 minutes to an en-route alternate aerodrome including extended diversion time operations (EDTO).....	4-17
4.8 Carry-on baggage.....	4-19
4.9 Additional requirements for single pilot operations under the instrument flight rules (IFR) or at night	4-19
4.10 Fatigue management.....	4-19
CHAPTER 5. Aeroplane performance operating limitations.....	5-1
5.1 General	5-1
5.2 Applicable to aeroplanes certificated in accordance with Parts IIIA and IIIB of Annex 8.....	5-1
5.3 Obstacle data.....	5-3
5.4 Additional requirements for operations of single-engine turbine-powered aeroplanes at night and/or in Instrument Meteorological Conditions (IMC).....	5-3
CHAPTER 6. Aeroplane instruments, equipment and flight documents	6-1
6.1 General	6-1

	<i>Page</i>
6.2 All aeroplanes on all flights	6-1
6.3 Flight recorders	6-4
6.4 All aeroplanes operated as VFR flights	6-10
6.5 All aeroplanes on flights over water	6-10
6.6 All aeroplanes on flights over designated land areas	6-11
6.7 All aeroplanes on high altitude flights	6-11
6.8 All aeroplanes in icing conditions	6-12
6.9 All aeroplanes operated in accordance with instrument flight rules	6-12
6.10 All aeroplanes when operated at night.....	6-13
6.11 Pressurized aeroplanes when carrying passengers — weather radar	6-14
6.12 All aeroplanes operated above 15 000 m (49 000 ft) — radiation indicator.....	6-14
6.13 All aeroplanes complying with the noise certification Standards in Annex 16, Volume I	6-14
6.14 Mach number indicator.....	6-14
6.15 Aeroplanes required to be equipped with ground proximity warning systems (GPWS)	6-14
6.16 Aeroplanes carrying passengers — cabin crew seats.....	6-15
6.17 Emergency locator transmitter (ELT).....	6-16
6.18 Aeroplanes required to be equipped with an airborne collision avoidance system (ACAS II).....	6-16
6.19 Requirements for pressure-altitude reporting transponders	6-16
6.20 Microphones	6-17
6.21 Turbo-jet aeroplanes — forward-looking wind shear warning system.....	6-17
6.22 All aeroplanes operated by a single pilot under the instrument flight rules (IFR) or at night.....	6-17
6.23 Aeroplanes equipped with head-up displays (HUD) and/or enhanced vision systems (EVS).....	6-18
CHAPTER 7. Aeroplane communication and navigation equipment.....	7-1
7.1 Communication equipment.....	7-1
7.2 Navigation equipment.....	7-1
7.3 Installation	7-3
7.4 Electronic navigation data management	7-4
CHAPTER 8. Aeroplane maintenance.....	8-1
8.1 Operator's maintenance responsibilities	8-1
8.2 Operator's maintenance control manual	8-1
8.3 Maintenance programme	8-2
8.4 Maintenance records.....	8-2
8.5 Continuing airworthiness information	8-3
8.6 Modifications and repairs	8-3
8.7 Approved maintenance organization	8-3
8.8 Maintenance release.....	8-6
CHAPTER 9. Aeroplane flight crew	9-1
9.1 Composition of the flight crew	9-1
9.2 Flight crew member emergency duties	9-1
9.3 Flight crew member training programmes.....	9-1
9.4 Qualifications.....	9-3
9.5 Flight crew equipment	9-5
CHAPTER 10. Flight operations officer/flight dispatcher.....	10-1

	<i>Page</i>
CHAPTER 11. Manuals, logs and records	11-1
11.1 Flight manual	11-1
11.2 Operator's maintenance control manual	11-1
11.3 Maintenance programme	11-2
11.4 Journey log book	11-2
11.5 Records of emergency and survival equipment carried	11-3
11.6 Flight recorder records	11-3
CHAPTER 12. Cabin crew	12-1
12.1 Assignment of emergency duties	12-1
12.2 Cabin crew at emergency evacuation stations	12-1
12.3 Protection of cabin crew during flight	12-1
12.4 Training	12-1
CHAPTER 13. Security	13-1
13.1 Domestic commercial operations	13-1
13.2 Security of the flight crew compartment	13-1
13.3 Aeroplane search procedure checklist	13-2
13.4 Training programmes	13-2
13.5 Reporting acts of unlawful interference	13-2
13.6 Miscellaneous	13-2
APPENDIX 1. Lights to be displayed by aeroplanes	APP 1-1
1. Terminology	APP 1-1
2. Navigation lights to be displayed in the air	APP 1-1
3. Lights to be displayed on the water	APP 1-2
APPENDIX 2. Organization and contents of an operations manual	APP 2-1
1. Organization	APP 2-1
2. Contents	APP 2-1
APPENDIX 3. Additional requirements for approved operations by single-engine turbine-powered aeroplanes at night and/or in Instrument Meteorological Conditions (IMC)	APP 3-1
1. Turbine engine reliability	APP 3-1
2. Systems and equipment	APP 3-1
3. Minimum equipment list	APP 3-2
4. Flight manual information	APP 3-2
5. Event reporting	APP 3-2
6. Operator planning	APP 3-3
7. Flight crew experience, training and checking	APP 3-3
8. Route limitations over water	APP 3-3
9. Operator certification or validation	APP 3-4
APPENDIX 4. Altimetry system performance requirements for operations in RVSM airspace	APP 4-1

APPENDIX 5. Safety oversight of air operators	APP 5-1
1. Primary aviation legislation.....	APP 5-1
2. Specific operating regulations	APP 5-1
3. CAA structure and safety oversight functions	APP 5-1
4. Technical guidance.....	APP 5-2
5. Qualified technical personnel	APP 5-2
6. Licensing and certification obligations.....	APP 5-2
7. Continued surveillance obligations	APP 5-2
8. Resolution of safety issues	APP 5-3
APPENDIX 6. Air operator certificate	APP 6-1
1. Purpose and scope	APP 6-1
2. AOC template.....	APP 6-1
3. Operations specifications for each aircraft model	APP 6-2
APPENDIX 7. Framework for safety management systems (SMS)	APP 7-1
APPENDIX 8. Fatigue risk management system requirements	APP 8-1
1. FRMS policy and documentation	APP 8-1
2. Fatigue risk management processes	APP 8-2
3. FRMS safety assurance processes	APP 8-3
4. FRMS promotion processes	APP 8-4
APPENDIX 9. Flight recorders	APP 9-1
1. General requirements.....	APP 9-1
2. Flight Data Recorder (FDR)	APP 9-2
3. Cockpit Voice Recorder (CVR) and Cockpit Audio Recording System (CARS).....	APP 9-5
4. Airborne Image Recorder (AIR)	APP 9-6
5. Data Link Recorder (DLR).....	APP 9-6
6. Aircraft Data Recording Systems (ADRS)	APP 9-7
7. Inspections of flight recorder systems	APP 9-7
ATTACHMENT A. Guidance material for development of prescriptive fatigue management regulations	ATT A-1
1. Purpose and scope	ATT A-1
2. Operational concepts	ATT A-1
3. Types of limitations.....	ATT A-2
4. Guidelines for establishing prescriptive limitations for fatigue management	ATT A-3
ATTACHMENT B. Medical supplies	ATT B-1
1. Types	ATT B-1
2. Number of first-aid kits and universal precaution kits.....	ATT B-1
3. Location.....	ATT B-2
4. Contents.....	ATT B-2

	<i>Page</i>
ATTACHMENT C. Aeroplane operating limitations	ATT C-1
1. Purpose and scope	ATT C-1
2. Definitions	ATT C-1
3. General	ATT C-3
4. Aeroplane take-off performance limitations	ATT C-3
5. Take-off obstacle clearance limitations	ATT C-4
6. En-route limitations	ATT C-5
7. Landing limitations	ATT C-6
 Example 1	
1. Purpose and scope	ATT C-8
2. Stalling speed — minimum steady flight speed	ATT C-8
3. Take-off	ATT C-9
4. En route	ATT C-11
5. Landing	ATT C-12
 Appendix to Example 1	
1. General	ATT C-13
2. Take-off	ATT C-14
3. Landing	ATT C-18
 Example 2	
1. Purpose and scope	ATT C-20
2. Take-off	ATT C-22
3. En route	ATT C-22
4. Landing	ATT C-23
 Appendix to Example 2	
1. General	ATT C-24
2. Take-off	ATT C-24
3. Landing	ATT C-30
 ATTACHMENT D. Guidance for operations by turbine-engined aeroplanes beyond 60 minutes to an en-route alternate aerodrome including extended diversion time operations (ETDO)	ATT D-1
1. Introduction	ATT D-1
2. Operations by aeroplanes with turbine engines beyond 60 minutes to an en-route alternate aerodrome	ATT D-1
3. Extended diversion time operations (EDTO) requirements	ATT D-5
 ATTACHMENT E. Air operator certification and validation	ATT E-1
1. Purpose and scope	ATT E-1
2. Required technical safety evaluations	ATT E-1
3. Approval actions	ATT E-3
4. Acceptance actions	ATT E-6
5. Other approval or acceptance considerations	ATT E-7
6. Validation of the standard of operations	ATT E-8
7. Amendment of air operator certificates	ATT E-8

ATTACHMENT F. Minimum equipment list (MEL)	ATT F-1
ATTACHMENT G. Flight safety documents system	ATT G-1
1. Introduction	ATT G-1
2. Organization	ATT G-1
3. Validation	ATT G-2
4. Design.....	ATT G-2
5. Deployment	ATT G-2
6. Amendment	ATT G-2
ATTACHMENT H. Additional guidance for approved operations by single-engine turbine-powered aeroplanes at night and/or in Instrument Meteorological Conditions (IMC)	ATT H-1
1. Purpose and scope	ATT H-1
2. Turbine engine reliability	ATT H-1
3. Operations manual.....	ATT H-2
4. Operator certification or validation	ATT H-2
5. Operational and maintenance programme requirements	ATT H-3
6. Route limitations over water	ATT H-3
ATTACHMENT I. Framework for the State safety programme (SSP)	ATT I-1
ATTACHMENT J. Head-up displays (HUD) and enhanced vision systems (EVS).....	ATT J-1
1. HUD	ATT J-1
2. EVS	ATT J-3
ATTACHMENT K. Rescue and fire fighting service (RFFS) levels	ATT K-1
1. Purpose and scope	ATT K-1
2. Glossary of terms.....	ATT K-1
3. Minimum acceptable aerodrome RFFS category	ATT K-2

ABBREVIATIONS AND SYMBOLS*(used in this Annex)**Abbreviations*

AC	Alternating current
ACAS	Airborne collision avoidance system
ADRS	Aircraft data recording system
ADS	Automatic dependent surveillance
ADS-C	Automatic dependent surveillance — contract
AEO	All engines operative
AFCS	Automatic flight control system
AGA	Aerodromes, air routes and ground aids
AIG	Accident investigation and prevention
AIR	Airborne image recorder
AIRS	Airborne image recording system
AOC	Aeronautical operational control
AOC	Air operator certificate
APU	Auxiliary power unit
ASDA	Accelerate stop distance available
ASE	Altimetry system error
ASIA/PAC	Asia/Pacific
ATC	Air traffic control
ATM	Air traffic management
ATS	Air traffic services
CARS	Cockpit audio recording system
CAS	Calibrated airspeed
CAT I	Category I
CAT II	Category II
CAT III	Category III
CAT IIIA	Category IIIA
CAT IIIB	Category IIIB
CAT IIIC	Category IIIC
CDL	Configuration deviation list
CFIT	Controlled flight into terrain
cm	Centimetre
CPDLC	Controller-pilot data link communications
CVR	Cockpit voice recorder
DA	Decision altitude
DA/H	Decision altitude/height
DC	Device control
D-FIS	Data link-flight information services
DH	Decision height
DLR	Data link recorder
DLRS	Data link recording system
DME	Distance measuring equipment
DSTRK	Desired track
ECAM	Electronic centralized aircraft monitor
EDTO	Extended diversion time operations
EFIS	Electronic flight instrument system
EGT	Exhaust gas temperature

EICAS	Engine indication and crew alerting system
ELT	Emergency locator transmitter
ELT(AD)	Automatic deployable ELT
ELT(AF)	Automatic fixed ELT
ELT(AP)	Automatic portable ELT
ELT(S)	Survival ELT
EPR	Engine pressure ratio
EUROCAE	European Organization for Civil Aviation Equipment
EVS	Enhanced vision system
FDAP	Flight data analysis programmes
FDAU	Flight data acquisition unit
FDR	Flight data recorder
FL	Flight level
FM	Frequency modulation
ft	Foot
ft/min	Feet per minute
g	Normal acceleration
GCAS	Ground collision avoidance system
GNSS	Global navigation satellite system
GPWS	Ground proximity warning system
hPa	Hectopascal
HUD	Head-up display
IFR	Instrument flight rules
ILS	Instrument landing system
IMC	Instrument meteorological conditions
INS	Inertial navigation system
ISA	International standard atmosphere
kg	Kilogram
kg/m ²	Kilogram per metre squared
km	Kilometre
km/h	Kilometre per hour
kt	Knot
kt/s	Knots per second
lb	Pound
LDA	Landing distance available
m	Metre
MDA	Minimum descent altitude
MDA/H	Minimum descent altitude/height
MDH	Minimum descent height
MEL	Minimum equipment list
MHz	Megahertz
MLS	Microwave landing system
MMEL	Master minimum equipment list
MNPS	Minimum navigation performance specifications
MOPS	Minimum Operational Performance Specification
m/s	Metres per second
m/s ²	Metres per second squared

N	Newton
N ₁	Low pressure compressor speed (two-stage compressor); fan speed (three-stage compressor)
N ₂	High pressure compressor speed (two-stage compressor); intermediate pressure compressor speed (three-stage compressor)
N ₃	High pressure compressor speed (three stage compressor)
NAV	Navigation
NM	Nautical mile
OCA	Obstacle clearance altitude
OCA/H	Obstacle clearance altitude/height
OCH	Obstacle clearance height
OEI	One engine inoperative
PANS	Procedures for Air Navigation Services
PBN	Performance-based navigation
RCP	Required communication performance
RNAV	Area navigation
RNP	Required navigation performance
RVR	Runway visual range
RVSM	Reduced vertical separation minima
SICASP	Secondary Surveillance Radar Improvements and Collision Avoidance Systems Panel
SOP	Standard operating procedures
SST	Supersonic transport
STOL	Short take-off and landing
TAS	True airspeed
TAWS	Terrain awareness warning system
TCAS	Traffic alert and collision avoidance system
TLA	Thrust lever angle
TLS	Target level of safety
TODA	Take-off distance available
TORA	Take-off run available
TVE	Total vertical error
UTC	Coordinated universal time
VFR	Visual flight rules
V _D	Design diving speed
VMC	Visual meteorological conditions
V _{MC}	Minimum control speed with the critical engine inoperative
VOR	VHF omnidirectional radio range
V _{s0}	Stalling speed or the minimum steady flight speed in the landing configuration
V _{s1}	Stalling speed or the minimum steady flight speed in a specified configuration
VTOL	Vertical take-off and landing
WXR	Weather

Symbols

°C	Degrees Celsius
%	Per cent

PUBLICATIONS
(referred to in this Annex)

Convention on International Civil Aviation (Doc 7300)

European Organization for Civil Aviation Equipment (EUROCAE)
Documents ED55 and ED56A

International Regulations for Preventing Collisions at Sea

Policy and Guidance Material on the Economic Regulation of International Air Transport (Doc 9587)

Protocol Relating to an Amendment to the Convention on International Civil Aviation (Article 83 bis) (Doc 9318)

Annexes to the Convention on International Civil Aviation

Annex 1 — *Personnel Licensing*

Annex 2 — *Rules of the Air*

Annex 3 — *Meteorological Service for International Air Navigation*

Annex 4 — *Aeronautical Charts*

Annex 5 — *Units of Measurement to be Used in Air and Ground Operations*

Annex 6 — *Operation of Aircraft*
Part II — *International General Aviation — Aeroplanes*
Part III — *International Operations — Helicopters*

Annex 7 — *Aircraft Nationality and Registration Marks*

Annex 8 — *Airworthiness of Aircraft*

Annex 9 — *Facilitation*

Annex 10 — *Aeronautical Telecommunications*
Volume III (Part I — *Digital Data Communication Systems*;
Part II — *Voice Communication Systems*)
Volume IV (*Surveillance and Collision Avoidance Systems*)

Annex 11 — *Air Traffic Services*

Annex 12 — *Search and Rescue*

Annex 13 — *Aircraft Accident and Incident Investigation*

Annex 14 — *Aerodromes*
Volume I — *Aerodrome Design and Operations*

Annex 15 — *Aeronautical Information Services*

Annex 16 — Environmental Protection
Volume I — *Aircraft Noise*

Annex 18 — *The Safe Transport of Dangerous Goods by Air*

Procedures for Air Navigation Services

ATM — Air Traffic Management (Doc 4444)
OPS — Aircraft Operations (Doc 8168)
Volume I — *Flight Procedures*
Volume II — *Construction of Visual and Instrument Flight Procedures*
TRG — Training (Doc 9868)

Regional Supplementary Procedures (Doc 7030)

Manuals

Airport Services Manual (Doc 9137)
Part 1 — *Rescue and Fire Fighting*
Part 8 — *Airport Operational Services*

Airworthiness Manual (Doc 9760)

Fatigue Risk Management Systems Manual for Regulators (Doc 9966)

Flight Planning and Fuel Management Manual (Doc 9976)

Human Factors Training Manual (Doc 9683)

Manual of Aircraft Ground De-icing/Anti-icing Operations (Doc 9640)

Manual of All-Weather Operations (Doc 9365)

Manual of Criteria for the Qualification of Flight Simulation Training Devices (Doc 9625)

Manual of Procedures for Establishment and Management of a State's Personnel Licensing System (Doc 9379)

Manual of Procedures for Operations Inspection, Certification and Continued Surveillance (Doc 8335)

Manual on Flight Data Analysis Programmes (FDAP) (Doc 10000)

Manual on Implementation of a 300 m (1 000 ft) Vertical Separation Minimum Between FL 290 and FL 410 Inclusive (Doc 9574)

Manual on Required Communications Performance (RCP) (Doc 9869)

Performance-based Navigation (PBN) Manual (Doc 9613)

Preparation of an Operations Manual (Doc 9376)

Safety Management Manual (SMM) (Doc 9859)

Safety Oversight Manual (Doc 9734)
Part A — *The Establishment and Management of a State's Safety Oversight System*

Training Manual (Doc 7192)

Part D-3 — Flight Operations Officers/Flight Dispatchers

Circulars

Guidance Material on SST Aircraft Operations (Cir 126)

Guidance on the Implementation of Article 83 bis of the Convention on International Civil Aviation (Cir 295)

ANNEX 6 — PART I

INTERNATIONAL COMMERCIAL AIR TRANSPORT — AEROPLANES

FOREWORD

Historical background

Standards and Recommended Practices for the Operation of Aircraft — International Commercial Air Transport were first adopted by the Council on 10 December 1948 pursuant to the provisions of Article 37 of the Convention on International Civil Aviation (Chicago, 1944) and designated as Annex 6 to the Convention. They became effective on 15 July 1949. The Standards and Recommended Practices were based on recommendations of the Operations Division at its first session in April 1946, which were further developed at the second session of the Division in February 1947.

Amendments to the Annex, which included additional Standards and Recommended Practices as well as modifications to existing Standards, and which were based on recommendations of the Operations Division at its third and fourth sessions in February–March 1949 and March–April 1951, were adopted by the Council on 5 December 1950 (Amendments 1–127), 4 December 1951 (Amendments 128–131), 28 November 1952 (Amendments 132 and 133), 2 December 1952 (Amendment 134), 20 October 1953 (Amendment 135), 23 February 1956 (Amendment 136), 8 May 1956 (Amendment 137) and 15 May 1956 (Amendment 138), and became effective on 1 June 1951, 1 May 1952, 1 April 1953, 1 May 1953, 1 March 1954, 1 July 1956, 1 September 1956 and 15 September 1956, respectively.

The Third Air Navigation Conference (Montreal, September–October 1956) made, among other things, a complete review of Chapter 5 of the Annex. As a result of those recommendations, their submission to all Contracting States, and their review by the Air Navigation Commission, a complete new text of Chapter 5 was adopted by the Council as Amendment 139 on 13 June 1957 and became effective on 1 October 1957.

Additionally, the Council adopted Amendment 140 on 13 June 1957, containing amendments to Chapter 6 covering the marking of break-in points on aircraft and the characteristics of navigation lights, to Chapter 8 respecting the qualification of persons to certify aircraft as airworthy, to Chapter 9 respecting the route and aerodrome qualification of pilots and to Chapter 10 respecting requirements for licensing of flight operations officers, which became effective on 1 October 1957. Subsequent to the issuance of the fifth edition, Amendment 141 (4.1.1 and 4.1.2) was adopted by the Council on 12 May 1958 and became applicable on 1 December 1958. On 8 December 1959 the Council adopted Amendment 142 relating to the provisions in Chapter 6 for the carriage of portable emergency radio transmitters. The Amendment became effective on 1 May 1960 and applicable on 1 August 1960. On 2 December 1960 the Council adopted Amendment 143 relating to the provisions in Chapter 4 for coordination of operational instructions involving a change in the air traffic control flight plan. The Amendment became effective on 1 April 1961 and applicable on 1 July 1961. On 24 March 1961 the Council adopted Amendment 144 relating to the establishment of limitations upon flight duty periods and provision of rest periods for flight crew members, and the Attachment to the Annex of guidance material on the establishment of flight time and flight duty period limitations and rest periods. The Amendment became effective on 1 August 1961 and applicable on 1 October 1961. The Council on 24 March 1961 approved Amendment 145 containing the Note under 6.2.2 a). On 13 December 1961 the Council adopted Amendments 146 and 147 and approved Amendment 148. These relate respectively to the modernizing of the specifications concerning the provision and use of oxygen supply systems, the installation of high intensity anti-collision lights on aeroplanes and to purely editorial changes respecting references to other documents. The Amendments became effective on 1 April 1962 and applicable on 1 July 1962. On 8 April 1963 the Council adopted Amendment 149. This Amendment related to the specification of the circumstances under

which emergency and survival equipment shall be carried on long-range over-water flights. The Amendment became effective on 1 August 1963 and applicable on 1 November 1963.

As a result of the adoption of Amendment 150, a sixth edition of the Annex was published. This was necessitated by the extensive nature of the Amendment which followed recommendations of the Fourth Air Navigation Conference (Montreal, November–December 1965) for extensive revision of the Annex, chiefly with the aim of bringing it up to date to meet the operational needs of high performance turbo-jet aeroplanes. Furthermore, on the recommendation of the Conference, the applicability of the Annex is now limited to “aeroplanes” engaged in scheduled and non-scheduled international air transport operations. Previously this limitation applied only to non-scheduled international air transport operations. Amendment 150 was adopted by the Council on 14 December 1966, became effective on 14 April 1967 and applicable on 24 August 1967.

The Council, on 8 November 1967, adopted Amendment 151 which redefined “Aircraft” as a result of adoption by Council of Amendment 2 to Annex 7 to the Convention and amended 5.2.7.2.2 to cater for three-engined aeroplanes. The Amendment became effective on 8 March 1968 and applicable on 22 August 1968.

Amendment 152 was adopted by the Council on 23 January 1969. Besides revising certain paragraphs in Chapters 4, 7 and 8 to give them more precision, the Amendment also adds a provision in Chapter 4 which prohibits, when passengers are being carried, the in-flight simulation of emergency situations affecting the flight characteristics of the aeroplane. The opportunity presented by this Amendment was also taken to introduce changes to the Annex as a consequence of the adoption by the Council of a companion document — International Standards and Recommended Practices — *Operation of Aircraft* — Annex 6, Part II — *International General Aviation*. These changes consisted of designating this document, previously known as Annex 6, “Annex 6, Part I, First Edition”. Amendment 152 became effective on 23 May 1969 and applicable on 18 September 1969.

Consequent to the adoption of Annex 6, Part III, *International Operations — Helicopters*, an amendment to the title was introduced to indicate that Annex 6, Part I was applicable only to aeroplanes.

Table A shows the origin of subsequent amendments together with a list of the principal subjects involved and the dates on which the Annex and the amendments were adopted by the Council, when they became effective and when they became applicable.

Applicability

The present edition of Annex 6, Part I, contains Standards and Recommended Practices adopted by the International Civil Aviation Organization as the minimum Standards applicable to the operation of aeroplanes by operators authorized to conduct international commercial air transport operations. These international commercial air transport operations include scheduled international air services and non-scheduled international air transport operations for remuneration or hire.

In conjunction, these two types of operations include all international air transport operations conducted for remuneration or hire by aeroplanes. The distinction between them lies in the fact that scheduled international air services are especially provided for in the Convention in contradistinction to international air transport operations in general, of which non-scheduled international air transport operations for remuneration or hire were considered most urgently to require the establishment of International Standards and Recommended Practices. It is no longer considered necessary to differentiate in the Standards and Recommended Practices between scheduled international air services and non-scheduled international air transport operations.

The purpose of Annex 6, Part I, is to contribute to the safety of international air navigation by providing criteria of safe operating practice and to contribute to the efficiency and regularity of international air navigation by encouraging States to facilitate the passage over their territories of aeroplanes in international commercial air transport belonging to other States that operate in conformity with such Standards.

Chapter 5

An element of the safety of an operation is the intrinsic safety of the aircraft, that is, its level of airworthiness. The level of airworthiness of an aircraft is, however, not fully defined by the application of the airworthiness Standards of Annex 8, but also requires the application of those Standards in the present Annex that are complementary to them.

As originally adopted and also as amended by Amendments 1 to 138, the Annex contained a chapter “Aeroplane Operating Limitations” which included general provisions applicable to the operation of all aeroplanes within the scope of the Annex, a section or sections applicable to aeroplanes certificated in ICAO categories according to the then existent Annex 8, and a section applicable to aeroplanes not so certificated.

At its fourth session, the Operations Division, collaborating with the Airworthiness Division, made, in addition to the proposals that resulted in Amendments 128 to 133, recommendations concerning the use of a performance code as an alternative to the one prescribed for ICAO Category A aeroplanes in which some essential climb values had the status of Recommended Practices. Further, the Airworthiness Division made recommendations concerning certain aspects of the certification in ICAO categories. As a result of those recommendations, the Council, on 2 December 1952, adopted Amendment 134 (which became effective 1 May 1953), and approved the incorporation of the alternative performance code as Attachment A but stated its belief that since agreement had not yet been reached on Standards covering performance, there existed no basis for certification in ICAO Category A. It urged the Contracting States to refrain from such certification pending the becoming effective of Standards on performance or until such time as the Council decides on the basic policy on airworthiness.

The Assembly at its seventh session (June 1953) endorsed the action already taken by the Council and the Air Navigation Commission to initiate a fundamental study of ICAO policy on international airworthiness and directed the Council to complete the study as rapidly as practicable.

In pursuing such study, the Air Navigation Commission was helped by an international body of experts designated as the “Airworthiness Panel”, which contributed to the preparation of the work of the Third Air Navigation Conference.

As a result of these studies, a revised policy on international airworthiness was developed and it was approved by the Council in 1956. According to this policy the principle of certification in an ICAO Category was abandoned. Instead, Annex 8 included broad Standards which defined, for application by the competent national authorities, the complete minimum international basis for the recognition by States of certificates of airworthiness for the purpose of the flight of aircraft of other States into or over their territories, thereby achieving, among other purposes, protection of other aircraft, third persons and property. It was considered that this met the obligation of the Organization under Article 37 of the Convention to adopt international Standards of airworthiness.

It was recognized that the ICAO Standards of airworthiness would not replace national regulations and that national codes of airworthiness containing the full scope and extent of detail considered necessary by individual States would be necessary as the basis for the certification of individual aircraft. Each State would establish its own comprehensive and detailed code of airworthiness or would select a comprehensive and detailed code established by another Contracting State. The level of airworthiness defined by this code would be indicated by the Standards, supplemented, if necessary, by Acceptable Means of Compliance.

A revised text consistent with the above principles was prepared for Chapter 5 of Annex 6. It included: a) broad Standards that were complementary to the Standards related to aeroplane performance in Annex 8; and b) two Acceptable Means of Compliance which illustrated by examples the level of performance intended by the broad Standards. To adopt a code giving an appreciably lower level of performance than that illustrated by these Acceptable Means of Compliance was considered to be a violation of the Standards in Chapter 5 of this Annex.

Present policy on international airworthiness. There had been some concern about the slow progress that had been made over the years with respect to developing supplementary airworthiness specifications in the form of Acceptable Means of Compliance. It was noted that the majority of the Acceptable Means of Compliance in Annexes 6 and 8 had been developed in

1957 and were therefore applicable to only those aeroplane types operating at that time. No effort had been made to update the specifications in these Acceptable Means of Compliance nor had there been any recommendations from the Airworthiness Committee for upgrading of any of the Provisional Acceptable Means of Compliance, which had been developed as potential material for full-fledged Acceptable Means of Compliance. The Air Navigation Commission therefore requested the Airworthiness Committee to review the progress made by it since its inception with a view to determining whether or not desired results had been achieved and to recommend any changes to improve the development of detailed airworthiness specifications.

The Airworthiness Committee at its Ninth Meeting (Montreal, November/December 1970) made a detailed study of the problems and recommended that the concept of developing airworthiness specifications in the form of Acceptable Means of Compliance and Provisional Acceptable Means of Compliance be abandoned and a provision be made for an airworthiness technical manual to be prepared and published by ICAO to include guidance material intended to facilitate the development and uniformity of national airworthiness codes by Contracting States.

The Air Navigation Commission reviewed the recommendations of the Airworthiness Committee in the light of the history of the development of the airworthiness policy approved by the Council in 1956. It came to the conclusion that the basic objectives and principles on which the ICAO airworthiness policy had been based were sound and did not require any significant change. It was also concluded that the main reason for the slow progress in the development of airworthiness specifications in the form of Acceptable Means of Compliance and Provisional Acceptable Means of Compliance was the degree of mandatory status to the former implied by the following statement included in the Forewords of Annexes 6 and 8:

“To adopt a code giving an appreciably lower level of airworthiness than that given in an Acceptable Means of Compliance would be a violation of the Standard supplemented by that Acceptable Means of Compliance.”

Several approaches were examined by the Air Navigation Commission to eliminate this difficulty. Finally, it came to the conclusion that the idea of developing airworthiness specifications in the form of Acceptable Means of Compliance and Provisional Acceptable Means of Compliance should be abandoned and ICAO should declare that the States' obligations, for the purpose of Article 33 of the Convention, shall be met by their compliance with the broad Standards in Annex 8 supplemented, as necessary, by airworthiness technical guidance material, devoid of all mandatory implications or obligations. Also the requirement that each Contracting State should either establish its own comprehensive and detailed code of airworthiness or select a comprehensive and detailed code established by another Contracting State should be retained.

The Council on 15 March 1972 approved the above approach to form the basis for the present policy of ICAO in the field of airworthiness.

It also approved the issuance of the airworthiness guidance material under the title of *Airworthiness Technical Manual*. It was understood that the guidance material would have no formal status and its main purpose would be to provide guidance to Contracting States in developing the detailed national airworthiness code mentioned in 2.2 of Part II of Annex 8.

With respect to Annex 6, Part I, it was agreed that the guidance material in the Acceptable Means of Compliance for Aeroplane Performance Operating Limitations should be edited suitably and retained in the Annex but in the form of an Attachment (green pages).

Performance Standards of Annex 8. Chapter 2, Part IIIA, and Sub-part B, Part IIIB, of Annex 8 contain aeroplane performance Standards that are complementary to the Standards in Chapter 5 of this Annex. Both state broad objectives. The Council has urged Contracting States not to impose on visiting aeroplanes, not exempted by Article 41, operational requirements other than those established by the State of Registry, provided that those requirements assure the level of performance equivalent to that intended by the Standards of Chapter 5 of this Annex and the complementary Standards of Chapter 2, Part IIIA, and Sub-part B, Part IIIB, of Annex 8.

In respect of aircraft exempted by Article 41, Chapter 5 of this Annex contains a Recommended Practice to the effect that the State of Registry should ensure that the level of performance specified in 5.2 applicable to aeroplanes not exempted should be met as far as practicable by those aeroplanes. The Council has urged Contracting States not to impose on visiting aircraft

exempted by Article 41 requirements other than those established by the State of Registry provided that in establishing those requirements the State of Registry complied with the Recommended Practice. These recommendations complement one made by the Council in respect of aircraft exempted by Article 41, to the effect that Contracting States apply as far as practicable to aeroplanes over 5 700 kg mass intended for the carriage of passengers or cargo or mail in international air navigation, the Standards of Parts IIIA and IIIB of Annex 8.

Action by Contracting States

Notification of differences. The attention of Contracting States is drawn to the obligation imposed by Article 38 of the Convention by which Contracting States are required to notify the Organization of any differences between their national regulations and practices and the International Standards contained in this Annex and any amendments thereto. Contracting States are invited to extend such notification to any differences from the Recommended Practices contained in this Annex, and any amendments thereto when the notification of such differences is important for the safety of air navigation. Further, Contracting States are invited to keep the Organization currently informed of any differences which may subsequently occur or of the withdrawal of any differences previously notified. A specific request for notification of differences will be sent to Contracting States immediately after the adoption of each Amendment to this Annex.

Attention of States is also drawn to the provision of Annex 15 related to the publication of differences between their national regulations and practices and the related ICAO Standards and Recommended Practices through the Aeronautical Information Service, in addition to the obligation of States under Article 38 of the Convention.

Promulgation of information. The establishment and withdrawal of and changes to facilities, services and procedures affecting aircraft operations provided in accordance with the Standards and Recommended Practices specified in this Annex should be notified and take effect in accordance with the provisions of Annex 15.

Status of Annex components

An Annex is made up of the following component parts, not all of which, however, are necessarily found in every Annex; they have the status indicated.

1.—Material comprising the Annex proper

- a) *Standards and Recommended Practices* adopted by the Council under the provisions of the Convention. They are defined as follows:

Standard: Any specification for physical characteristics, configuration, matériel, performance, personnel or procedure, the uniform application of which is recognized as necessary for the safety or regularity of international air navigation and to which Contracting States will conform in accordance with the Convention; in the event of impossibility of compliance, notification to the Council is compulsory under Article 38.

Recommended Practice: Any specification for physical characteristics, configuration, matériel, performance, personnel or procedure, the uniform application of which is recognized as desirable in the interest of safety, regularity or efficiency of international air navigation, and to which Contracting States will endeavour to conform in accordance with the Convention.

- b) *Appendices* comprising material grouped separately for convenience but forming part of the Standards and Recommended Practices adopted by the Council.

- c) *Definitions* of terms used in the Standards and Recommended Practices which are not self-explanatory in that they do not have accepted dictionary meanings. A definition does not have an independent status but is an essential part of each Standard and Recommended Practice in which the term is used, since a change in the meaning of the term would affect the specification.
- d) *Tables* and *Figures* which add to or illustrate a Standard or Recommended Practice and which are referred to therein, form part of the associated Standard or Recommended Practice and have the same status.

It is to be noted that some Standards in this Annex incorporate, by reference, other specifications having the status of Recommended Practices. In such cases, the text of the Recommended Practice becomes part of the Standard.

2.— *Material approved by the Council for publication in association with the Standards and Recommended Practices*

- a) *Forewords* comprising historical and explanatory material based on the action of the Council and including an explanation of the obligations of States with regard to the application of the Standards and Recommended Practices ensuing from the Convention and the Resolution of Adoption;
- b) *Introductions* comprising explanatory material introduced at the beginning of parts, chapters or sections of the Annex to assist in the understanding of the application of the text;
- c) *Notes* included in the text, where appropriate, to give factual information or references bearing on the Standards or Recommended Practices in question but not constituting part of the Standards or Recommended Practices;
- d) *Attachments* comprising material supplementary to the Standards and Recommended Practices or included as a guide to their application.

Selection of language

This Annex has been adopted in six languages — English, Arabic, Chinese, French, Russian and Spanish. Each Contracting State is requested to select one of those texts for the purpose of national implementation and for other effects provided for in the Convention, either through direct use or through translation into its own national language, and to notify the Organization accordingly.

Editorial practices

The following practice has been adhered to in order to indicate at a glance the status of each statement: *Standards* have been printed in light face roman; *Recommended Practices* have been printed in light face italics, the status being indicated by the prefix **Recommendation**; *Notes* have been printed in light face italics, the status being indicated by the prefix *Note*.

The following editorial practice has been followed in the writing of specifications: for Standards the operative verb “shall” is used, and for Recommended Practices the operative verb “should” is used.

The units of measurement used in this document are in accordance with the International System of Units (SI) as specified in Annex 5 to the Convention on International Civil Aviation. Where Annex 5 permits the use of non-SI alternative units, these are shown in parentheses following the basic units. Where two sets of units are quoted it must not be assumed that the pairs of values are equal and interchangeable. It may, however, be inferred that an equivalent level of safety is achieved when either set of units is used exclusively.

Any reference to a portion of this document, which is identified by a number and/or title, includes all subdivisions of that portion.

Throughout this Annex, the use of the male gender should be understood to include male and female persons.

Table A. Amendments to Annex 6, Part I

<i>Amendment</i>	<i>Source(s)</i>	<i>Subject(s)</i>	<i>Adopted Effective Applicable</i>
1st Edition	Derived from Sixth Edition of Annex 6, including Amendment 152		23 January 1969 23 May 1969 18 September 1969
1 (2nd Edition)	Sixth Air Navigation Conference	<ul style="list-style-type: none"> a) A shift in emphasis of the responsibility for the establishment of minimum en-route flight altitudes from the operator to the State flown over; b) the requirement for additional instruments in aeroplanes operated as controlled VFR flights in the en-route phase; and, of special importance; c) the permitting of aeroplanes, when unable to navigate by visual references to landmarks, to be navigated by equipment other than radio navigation equipment, e.g. solely by self-contained navigation means, provided that certain equipment capabilities are met, thus eliminating any requirement for the carriage of radio navigation equipment. 	25 May 1970 25 September 1970 4 February 1971
2	Special Meeting on Aircraft Noise in the Vicinity of Aerodromes (1969) and the Second Meeting of the Supersonic Transport Panel	<ul style="list-style-type: none"> a) The weight of an aeroplane at the start of take-off or at the expected time of landing not to exceed, except in prescribed circumstances, the relative maximum weights at which compliance has been demonstrated with the applicable Noise Certification Standards; b) the carriage on board an aeroplane of a document attesting noise certification; c) all aeroplanes intended to be operated above 15 000 m (49 000 ft) to carry equipment to measure and indicate continuously the total cosmic radiation being received. 	2 April 1971 2 August 1971 6 January 1972
3	Council action in pursuance of Assembly Resolution A17-10	Inclusion in the Annex of a Recommended Practice to the effect that, in all passenger-carrying aeroplanes, the flight crew compartment door should be capable of being locked from within the compartment.	10 December 1971 10 April 1972 7 December 1972
4 (3rd Edition)	Air Navigation Commission Review of the Annex	<ul style="list-style-type: none"> a) Deletion from Chapter 2 of the provision which allowed, in prescribed circumstances, certain specifications classed as Standards to have the status of Recommended Practices; b) introduction of the term “Aerodrome operating minima” in lieu of “Aerodrome meteorological minima”; c) introduction of the terms “Decision height”, “Instrument meteorological conditions”, “Runway visual range” and “Visual meteorological conditions”; d) introduction of provisions to require the operator to provide a copy of its Operations Manual to the State of Registry and to incorporate in the Manual certain mandatory material; e) the inclusion of an updated list of the supplies, etc., to be carried aboard aircraft in first-aid kits; f) a change in the equivalent of 5 700 kg from 12 500 lb to 12 566 lb; g) the introduction of a reference to the need for certain types of aeroplanes to be equipped with a Mach number indicator; h) the introduction of a provision for cabin attendants to be seated and secured during certain prescribed flight phases. 	27 June 1972 27 October 1972 1 March 1973

<i>Amendment</i>	<i>Source(s)</i>	<i>Subject(s)</i>	<i>Adopted Effective Applicable</i>
5	Seventh Air Navigation Conference	Inclusion in the Annex of definitions of “Flight recorder” and “Maximum weight” (of aircraft) and revision of the specifications for the carriage, recording parameters and operation of flight recorders.	29 May 1973 1 October 1973 23 May 1974
6	In pursuance of new policy on international airworthiness and action in pursuance of Assembly Resolution A18-16	Replacement of the Acceptable Means of Compliance on Aeroplane Performance Operating Limitations by guidance material on the subject in the form of an Attachment, and incorporation of provisions for emergency power supply to operate attitude indicating instruments on the total failure of the main electrical generating system. The opportunity presented by this Amendment was also taken to revise the Introductory Note to Chapter 3 of the Annex. The revision points to a practical method for States to discharge their functions in the cases of lease, charter, and interchange of aircraft in international operations.	30 October 1973 28 February 1974 23 May 1974
7	Council action in pursuance of Assembly Resolutions A17-10 and A18-10	Introduced provisions relating to practices to be followed in the event that an aircraft is being subjected to unlawful interference.	7 December 1973 7 April 1974 23 May 1974
8	Pursuant to an Air Navigation Commission study concerning the interception of civil aircraft	Introduced provisions designed to reduce the risk for intercepted aircraft.	4 February 1975 4 June 1975 9 October 1975
9	Accident Investigation and Prevention Divisional Meeting (1974). Fifth Meeting of the Supersonic Transport Panel. Consequent to amendments to Annexes 3 and 14	Introduced requirements for the safeguarding and preservation of flight recorder records of aeroplanes involved in accidents and incidents, provision and use of flight crew restraining devices, procedures to be followed in the event of excessive cosmic radiation exposure during flight, and the maintenance of records for crew members on total cosmic radiation dosages. The Amendment also provided amplification of the specifications for the type of timepiece required for operations in accordance with Instrument Flight Rules and controlled VFR flights and provided a cross-reference to guidance material on SST fuel supplies. The opportunity presented by this Amendment was also taken to introduce changes to the Annex as a result of the adoption by the Council of amendments to companion documents — Annex 3 and Annex 14. These changes consist of the elimination of reference to PANS-MET and the revision of the definitions of Aerodrome, Runway Visual Range, Take-off Run Available and Landing Distance Available.	7 April 1976 7 August 1976 30 December 1976
10	ASIA/PAC Regional Air Navigation Meeting (1973)	The requirement for the carriage of survival radio equipment over those areas in which search and rescue would be especially difficult to be determined by States rather than regional air navigation agreement.	16 June 1976 16 October 1976 6 October 1977
11	Seventh Air Navigation Conference and Air Navigation Commission Study	Required the operator to establish operational procedures designed to ensure that an aeroplane conducting precision approaches crosses the threshold by a safe margin.	23 June 1977 23 October 1977 23 February 1978
12	Air Navigation Commission Study	Required the fitting of ground proximity warning systems to certain aeroplanes.	15 December 1977 15 April 1978 10 August 1978
13	Air Navigation Commission Study	Required the fitting of seats with safety harness and their use by cabin attendants assigned emergency evacuation duties.	13 December 1978 13 April 1979 29 November 1979

<i>Amendment</i>	<i>Source(s)</i>	<i>Subject(s)</i>	<i>Adopted Effective Applicable</i>
14	Air Navigation Commission Study	New definition of “operational control” and introduction of requirements for navigation equipment to meet minimum navigation performance specifications (MNPS)	2 April 1980 2 August 1980 27 November 1980
15	Air Navigation Commission Study	Revision of the provisions relating to exterior lights to align with new provisions in Annexes 2 and 8, and requirements to include a checklist of emergency and safety equipment, including instructions for its use, in the Operations Manual.	22 March 1982 22 July 1982 25 November 1982
16 (4th Edition)	Third and Fourth meetings of the Operations Panel, AGA Divisional Meeting (1981), amendments consequent to adoption of Annex 18 and an Air Navigation Study	Introduced provisions related to aircraft operating procedures for noise abatement, development and use of instrument flight procedures, authority and competence to taxi aeroplanes and refuelling with passengers on board. Changes to the Annex were introduced as a result of adoption by the Council of Annex 18 in respect to the carriage of dangerous goods and requirements for crew training programmes in their carriage in commercial aeroplanes. The provisions in respect of aerodromes operating minima were revised to clarify the requirements and to include a requirement for RVR information. Units of measurement were brought in line with the provisions of Annex 5, and the Note in Chapter 3 concerning lease, charter and interchange was updated.	29 March 1983 29 July 1983 24 November 1983
17	Accident Prevention and Investigation Divisional Meeting, AIG (1979)	Revision of the provisions relating to flight recorders. Introduction of related guidance material in an attachment.	6 March 1985 29 July 1985 21 November 1985
18	Seventh meeting of the Obstacle Clearance Panel, Air Navigation Commission studies and a proposal by a State	Provision of climb performance data with all engines operating; extended range operations by aeroplanes with two engines; the provision of obstacle data; take-off alignment distance accountability.	25 March 1986 27 July 1986 20 November 1986
19 (5th Edition)	Air Navigation Commission review of the Annex, Stage I. Third meeting of the Visual Flight Rules Operations Panel. Air Navigation Commission Study	<ul style="list-style-type: none"> a) Introduction of new definitions for commercial air transport operations, air operator certificate, master minimum equipment list and minimum equipment list. Introduction of revised definitions of aerial work and general aviation to Annex 6, Part I. Revision of the definition of alternate aerodrome to introduce take-off, en-route and destination alternate aerodromes; b) elimination of the differences between the specifications for scheduled and non-scheduled operations; c) introduction of the concept of the applicability of Annex 6, Part I to the operation of aeroplanes by operators authorized to conduct international commercial air transport operations; d) requirements for the issue of an air operator certificate and the introduction of guidance material; e) requirements for the development of minimum equipment lists and the introduction of guidance material; f) requirements for the specification of alternate aerodromes; g) requirement for the provision of an aircraft operating manual; h) requirement for the operator to establish an accident prevention and flight safety programme and specifications related to carry-on baggage; 	19 March 1990 30 July 1990 15 November 1990

<i>Amendment</i>	<i>Source(s)</i>	<i>Subject(s)</i>	<i>Adopted Effective Applicable</i>
		<ul style="list-style-type: none"> i) differentiation in Annex 6, Part I between operational and ATS flight plans; j) requirements for the pilot-in-command to demonstrate knowledge of long-range navigation procedures where appropriate; k) elimination of the term “controlled VFR flight” and recognition that a VFR flight may be a controlled flight; l) amendment to Chapter 13 — Security to make the recommendation on the provision of a lockable flight crew compartment door applicable to all aeroplanes rather than only passenger-carrying aeroplanes, to require guidance material to support the aeroplane search procedure checklist, and to require the operator to establish a training programme for employees in preventative measures and techniques in relation to acts of sabotage or unlawful interference; m) introduction of guidance material concerning flight data recording of important operational information in aeroplanes with electronic displays; n) revision of the requirements for the contents of the operations manual; o) requirements concerning carry-on baggage; p) change of the expression “flight check system” to “checklist”; 	
20	Fifth meeting of the Operations Panel, Seventh and Eighth meetings of the Review of the General Concept of Separation Panel, Accident Investigation Divisional meeting (AIG/1992), Third meeting of the Continuing Airworthiness Panel, Air Navigation Commission studies	<ul style="list-style-type: none"> a) Revision of definitions of aerodrome operating minima, decision altitude/height, minimum descent altitude/height and obstacle clearance altitude/height; b) introduction of new definitions for emergency locator transmitters (ELTs), required navigation performance (RNP) and RNP type; c) introduction of the definition for the classification of instrument approach and landing operations; d) introduction of a reference to the Continuing Airworthiness Manual; e) revision of the requirements concerning the use of engraving metal foil flight data recorders; f) introduction of carriage requirements for emergency locator transmitters (ELTs) to replace provisions regarding survival radio equipment and emergency location beacon; g) introduction of a requirement that the navigation equipment carried shall enable the aircraft to proceed in accordance with RNP types prescribed for the intended route(s) or areas(s), provisions to permit the uniform implementation of 300 m (1 000 ft) VSM above FL 290 and reference to the requirements relating to operations in RNP airspace in the operations manual; h) revision of the requirements concerning maintenance inspection, modifications and repairs and continuing airworthiness information. 	21 March 1994 25 July 1994 10 November 1994

<i>Amendment</i>	<i>Source(s)</i>	<i>Subject(s)</i>	<i>Adopted Effective Applicable</i>
21 (6th Edition)	Air Navigation Commission studies, Fourteenth meeting of the Dangerous Goods Panel, editorial amendment, text alignment with Annex 6, Part II and/or Part III, consequential amendment	<ul style="list-style-type: none"> a) Introduction of new and revised definitions for cabin attendant, flight manual, large aeroplane, operations manual and small aeroplane; b) revision of the provisions concerning operating facilities, flight preparation, flight time, flight duty periods and rest periods for crew members, oxygen supply and extended range operations (ETOPS); c) new requirements for determining the length of the runway available; d) revised and new provisions concerning ground proximity warning systems (GPWS), medical supplies, oxygen equipment for aeroplanes on high altitude flights; e) revision of the provisions concerning aeroplanes operated in accordance with instrument flight rules (IFR); f) inclusion of references to the ICAO <i>Manual of Criteria for the Qualification of Flight Simulators</i> (Doc 9625) and new requirements for the flight crew training programme concerning knowledge and skills related to human performance and limitations; g) revision of the denomination of flight operations officer to align with Annex 1; h) revision of the contents of the operations manual and new provisions concerning aerodrome operating minima, oxygen supply, flight and duty time limitations, departure contingency procedures, instructions for mass and balance control and instructions and training requirements for the avoidance of controlled flight into terrain (CFIT) and policy for the use of ground proximity warning systems (GPWS); i) new provisions on flight time, flight duty periods and rest periods for cabin attendants and revision of the provisions concerning training; and j) revised and new requirements related to the incorporation of security into aircraft design. 	8 March 1995 24 July 1995 9 November 1995
22	Fourth and Fifth meetings of the Secondary Surveillance Radar Improvements and Collision Avoidance Systems Panel (SICAS/4 and 5)	Requirements concerning pressure-altitude reporting transponders and carriage of airborne collision avoidance systems (ACAS).	19 February 1996 15 July 1996 7 November 1996
23 (7th Edition)	First meeting of the Flight Recorder Panel, Fourth meeting of the Continuing Airworthiness Panel, ICAO and Industry CFIT Task Force, Air Navigation Commission studies, Amendment 162 to Annex 1, Amendment 38 to Annex 11, editorial amendment	<ul style="list-style-type: none"> a) Introduction of new and revised definitions for aircraft operating manual, configuration deviation list, ETOPS en-route alternate, Human Factors principles, human performance, master minimum equipment list, maintenance, psychoactive substances and required navigation performance; b) revision of the notes concerning lease and interchange; c) new and revised requirements concerning flight recorders; d) introduction of a note concerning the use of psychoactive substances; e) new provisions concerning airborne forward-looking wind shear warning systems; 	19 March 1998 20 July 1998 5 November 1998

<i>Amendment</i>	<i>Source(s)</i>	<i>Subject(s)</i>	<i>Adopted Effective Applicable</i>
		f) new and revised provisions concerning continuing airworthiness to reflect the use of approved maintenance organizations and to clarify the responsibilities of the operator and the maintenance organization;	
		g) new and revised provisions concerning the content of an operations manual relocated in an appendix and a new Recommended Practice for the carriage of the ground proximity warning system in piston-engined aeroplanes;	
		h) new provisions concerning the responsibility of States with regard to supervision of operations subject to an air operator certificate, acceptance of an operations manual and establishment of a system for certification and continued surveillance of the operator;	
		i) new provisions related to the de-icing/anti-icing of aircraft on the ground, aeroplane performance operating limitations, mass limitation, sensitive pressure altimeters and recent experience of the co-pilot;	
		j) new provisions concerning the carriage of airborne collision avoidance (ACAS) systems and pressure-altitude reporting transponders; and	
		k) new provisions concerning Human Factors.	
24	Second meeting of the Flight Recorder Panel, 32nd Session of the Assembly, Air Navigation Commission studies	a) Change of terminology from “cabin attendant” to “cabin crew”;	15 March 1999
		b) revised definitions;	19 July 1999
		c) new provisions concerning the mandatory carriage of ELTs operating on 406 MHz and 121.5 MHz, the addition of a predictive terrain hazard warning function to the ground proximity warning system (GPWS) and the introduction of an implementation date for the recording of digital communications.	4 November 1999
25	Air Navigation Commission studies	a) Revised definitions; and	15 March 2000
		b) introduction of requirements for the provision of RVR and criteria for instrument approach operations, and revision of the duties of the pilot-in-command.	17 July 2000
			2 November 2000
26 (8th Edition)	Second meeting of the Flight Recorder Panel, AIG Divisional Meeting (1999), Third meeting of the Global Navigation Satellite System Panel, Fifth meeting of the Continuing Airworthiness Panel, Air Navigation Commission studies	a) Update of the provisions pertaining to flight recorders, including the recording of digital communications; FDR requirements for new aircraft; revised parameter listings; introduction of two-hour duration CVRs;	9 March 2001
		b) new provisions pertaining to flight data analysis programmes;	16 July 2001
		c) amendment of the classification of instrument approach and landing operations;	1 November 2001
		d) new provisions pertaining to approach with vertical guidance (APV) operations;	
		e) new definitions and update of provisions pertaining to maintenance-related requirements; and	
		f) translation into English of documents attesting noise certification.	
27	Air Navigation Commission studies	a) Revised requirements for the ground proximity warning system (GPWS) and forward looking terrain avoidance function; and	15 March 2002
		b) new and revised requirements for the incorporation of security into aircraft design.	15 July 2002
			28 November 2002

<i>Amendment</i>	<i>Source(s)</i>	<i>Subject(s)</i>	<i>Adopted Effective Applicable</i>
28	Separation and Airspace Safety Panel and Air Navigation Commission studies	<ul style="list-style-type: none"> a) New provision concerning language proficiency requirements; b) new definition and provision concerning an operator's flight safety documents system; c) new definition and provisions concerning the safety aspects of ground handling arrangements; d) authorization by the State of the Operator for operations in RNP airspace; and e) new provision concerning the content of an operations manual in regard to the airborne collision avoidance system (ACAS). 	<ul style="list-style-type: none"> 13 March 2003 14 July 2003 27 November 2003
29	Sixth meeting of the Operations Panel, and the Separation and Airspace Safety Panel	<ul style="list-style-type: none"> a) New definitions related to reduced vertical separation minimum (RVSM) operations and cruise relief pilots; b) new Standards 4.9.1 and 4.9.2, concerning single pilot operations under instrument flight rules (IFR) or at night; c) an exception to the operating limitations in 5.1.2 for approved single-engine turbine-powered aeroplanes; d) new Standards 5.4.1 and 5.4.2, specifying requirements for approval of commercial operations by single-engine turbine-powered aeroplanes in instrument meteorological conditions (IMC) or at night; e) new Standard 6.22, specifying aeroplane equipment requirements for single pilot operations under instrument flight rules (IFR) or at night; f) amendments to 7.2.4 regarding flight levels for reduced vertical separation minimum (RVSM) operations, and new Standards 7.2.5, 7.2.6 and 7.2.7, specifying the responsibility of the relevant State authority to take prompt and appropriate action if the monitoring results indicate that the height-keeping performance of a particular aircraft or an aircraft type group exceeds the prescribed limits; g) new Standards 7.4.1 and 7.4.2 concerning operator management of electronic navigation data products; h) amendments to Standards 9.4.1 and 9.4.2 concerning recent experience of the pilot-in-command, co-pilot and cruise relief pilot; i) amendments to Standards 9.4.3.5 and 9.4.3.6, concerning area, route and aerodrome qualifications of the pilot-in-command; j) new Standard 9.4.5.1 requiring States to specify requirements applicable to single pilot operations under the instrument flight rules or at night; k) a new Recommended Practice 9.4.5.2, specifying pilot-in-command experience and training requirements for single pilot operations under the instrument flight rules or at night; l) amendments to Appendix 2, regarding the contents of operations manuals in relation to area, route and aerodrome qualifications of the pilot-in-command, and maximum crosswind and tailwind operating limits; and 	<ul style="list-style-type: none"> 9 March 2005 11 July 2005 24 November 2005

<i>Amendment</i>	<i>Source(s)</i>	<i>Subject(s)</i>	<i>Adopted Effective Applicable</i>
		m) a new Appendix 3 specifying additional requirements for approved operations by single-engine turbine-powered aeroplanes at night and/ or in IMC, and a new Appendix 4 regarding the height-keeping performance criteria for operations in RVSM airspace.	
30	First meeting of the Surveillance and Conflict Resolution Systems Panel, Second meeting of the Flight Crew Licensing and Training Panel, Fourteenth meeting of the Obstacle Clearance Panel, a proposal by the United States, Council request, Assembly Resolution A35-17, 35th Session of the Assembly, and the Eleventh Air Navigation Conference	<p>a) The carriage of altitude encoders with higher resolution;</p> <p>b) pilot recent experience and proficiency check requirements, cross-crew qualification and cross-crediting of experience, evaluation of competency, threat and error management and the biannual pilot proficiency check;</p> <p>c) pilot awareness of operational requirements determined by procedure design;</p> <p>d) qualifications for flight operations officers/flight dispatchers and the critical elements of a State regulatory system;</p> <p>e) the carriage of a copy of the air operator certificate in aircraft;</p> <p>f) legal guidance for the protection of information from safety data collection and processing systems; and</p> <p>g) safety management provisions and references to new guidance material on the concept of acceptable level of safety.</p>	<p>14 March 2006</p> <p>17 July 2006</p> <p>23 November 2006</p>
31	First meeting of the Operational Data Link Panel (OPLINKP/1), First meeting of the Surveillance and Conflict Resolution Systems Panel (SCRSP/1) and Air Navigation Commission study	<p>a) Amendments to Standards to facilitate implementation of the available technology in relation to the use of automatic dependent surveillance — contract (ADS-C) and to the introduction of required communication performance (RCP) in the provision of air traffic services (ATS);</p> <p>b) amendment of existing provisions related to the mandatory carriage requirements of emergency locator transmitters (ELTs) as of 1 July 2008; and</p> <p>c) changes to Standards related to pressure-altitude data sources used by transponders as of 1 January 2009 and 1 January 2012.</p>	<p>14 March 2007</p> <p>16 July 2007</p> <p>22 November 2007</p> <p>1 July 2008</p> <p>1 January 2009</p> <p>1 January 2012</p>
32	Secretariat; Secretariat with the assistance of the Required Navigation Performance and Special Operational Requirements (RNPSOR) Study Group	<p>a) Amendments to definitions and Standards and Recommended Practices to strengthen the oversight and requirements of foreign operators and to harmonize the air operator certificate in content and, as of 1 January 2010, in layout; and</p> <p>b) amendments to definitions and Standards to align required navigation performance (RNP) and area navigation (RNAV) terminology with the performance-based navigation (PBN) concept.</p>	<p>3 March 2008</p> <p>20 July 2008</p> <p>20 November 2008</p> <p>1 January 2010</p>
33-A	Seventh meeting of the Operations Panel (OPSP/7); Secretariat with the assistance of the Medical Provisions Study Group (MPSG)	<p>a) Amendment to the definition of “approach and landing operations using instrument approach procedures” to show a reduced RVR requirement for CAT II and CAT IIIA and B;</p> <p>b) amendment to the provisions regarding limits for flight time, duty periods, flight duty periods and rest periods for fatigue management;</p> <p>c) new provisions for climbs and descents to reduce unnecessary ACAS II resolution advisories;</p> <p>d) clarification of training requirements for cabin crews in the awareness of dangerous goods;</p>	<p>2 March 2009</p> <p>20 July 2009</p> <p>19 November 2009</p>

<i>Amendment</i>	<i>Source(s)</i>	<i>Subject(s)</i>	<i>Adopted Effective Applicable</i>
		<ul style="list-style-type: none"> e) clarification of fuel and oil requirements in 4.3.6.2 and 4.3.6.3 with respect to distinguishing these requirements for piston-engined aeroplanes and for turbine-engined aeroplanes (turbo-jet and turbo-propeller); f) updated guidance on the level of performance intended by the provisions of Chapter 5; g) new Note in Appendix 2, 2.1.21 on the need to implement instructions on the use of autopilots and auto-throttles in IMC as an essential part of the CFIT and ALAR programmes; and h) amendment introducing changes to Annex 6 in order to better reflect the contemporary needs regarding on-board medical supplies. 	
33-B	Secretariat	Amendment concerning the development of harmonized provisions relating to safety management by introducing a framework for the implementation and maintenance of a State safety programme as of 18 November 2010.	2 March 2009 20 July 2009 18 November 2010
34	Secretariat, with the assistance of the Separation and Airspace Safety Panel (SASP); ninth meeting of the Operations Panel Working Group of the Whole (OPSP/WG/WHL/9); twelfth meeting of the Airworthiness Panel Working Group of the Whole (AIRP/WG/WHL/12); Secretariat, with the assistance of the second meeting of the Flight Recorder Panel Working Group of the Whole (FLIRECP/WG/WHL/2)	<ul style="list-style-type: none"> a) Amendment to the provisions concerning reduced vertical separation minimum (RVSM) long-term monitoring requirements; b) new provisions for head-up displays (HUD)/enhanced vision systems (EVS); c) amendment to provisions to provide consistency in propulsion terminology; and d) new and updated provisions regarding flight recorders. 	26 February 2010 12 July 2010 18 November 2010
35	Ninth and tenth meetings of the Operations Panel Working Group of the Whole (OPSP/WGWHL/9 and 10); Fatigue Risk Management Task Force (FRMSTF); Secretariat, in order to implement the Council mandate, pursuant to Assembly Resolution A37-9	<ul style="list-style-type: none"> a) amendment to the operational requirements related to the availability of rescue and fire fighting services (RFFS) at departure, destination or alternate aerodromes; b) new requirements for the development and implementation of fatigue risk management systems; and c) a halon replacement agent in lavatory fire extinguishers on or after 31 December 2011 and 31 December 2016 for hand-held fire extinguishers. 	13 June 2011 30 October 2011 15 December 2011

<i>Amendment</i>	<i>Source(s)</i>	<i>Subject(s)</i>	<i>Adopted Effective Applicable</i>
36	Secretariat, with the assistance of the third meeting of the Flight Recorder Panel Working Group of the Whole (FLIRECP/WG/WHL/3); Secretariat, with the assistance of the Special Operations Task Force (SOTF); Secretariat, in consultation with the Operations Panel (OPSP)	Amendment concerning: a) carriage requirements for flight recorders; b) extended diversion time operations (EDTO); and c) fuel planning, in-flight fuel management and the selection of alternate aerodromes; d) minimum fuel and MAYDAY fuel declarations.	7 March 2012 16 July 2012 15 November 2012

INTERNATIONAL STANDARDS AND RECOMMENDED PRACTICES

CHAPTER 1. DEFINITIONS

When the following terms are used in the Standards and Recommended Practices for operation of aircraft in international commercial air transport, they have the following meanings:

Accelerate-stop distance available (ASDA). The length of the take-off run available plus the length of stopway, if provided.

Aerial work. An aircraft operation in which an aircraft is used for specialized services such as agriculture, construction, photography, surveying, observation and patrol, search and rescue, aerial advertisement, etc.

Aerodrome. A defined area on land or water (including any buildings, installations and equipment) intended to be used either wholly or in part for the arrival, departure and surface movement of aircraft.

Aerodrome operating minima. The limits of usability of an aerodrome for:

- a) take-off, expressed in terms of runway visual range and/or visibility and, if necessary, cloud conditions;
- b) landing in precision approach and landing operations, expressed in terms of visibility and/or runway visual range and decision altitude/height (DA/H) as appropriate to the category of the operation;
- c) landing in approach and landing operations with vertical guidance, expressed in terms of visibility and/or runway visual range and decision altitude/height (DA/H); and
- d) landing in non-precision approach and landing operations, expressed in terms of visibility and/or runway visual range, minimum descent altitude/height (MDA/H) and, if necessary, cloud conditions.

Aeroplane. A power-driven heavier-than-air aircraft, deriving its lift in flight chiefly from aerodynamic reactions on surfaces which remain fixed under given conditions of flight.

Aircraft. Any machine that can derive support in the atmosphere from the reactions of the air other than the reactions of the air against the earth's surface.

Aircraft operating manual. A manual, acceptable to the State of the Operator, containing normal, abnormal and emergency procedures, checklists, limitations, performance information, details of the aircraft systems and other material relevant to the operation of the aircraft.

Note.— The aircraft operating manual is part of the operations manual.

Air operator certificate (AOC). A certificate authorizing an operator to carry out specified commercial air transport operations.

Airworthy. The status of an aircraft, engine, propeller or part when it conforms to its approved design and is in a condition for safe operation.

Alternate aerodrome. An aerodrome to which an aircraft may proceed when it becomes either impossible or inadvisable to proceed to or to land at the aerodrome of intended landing where the necessary services and facilities are available, where aircraft performance requirements can be met and which is operational at the expected time of use. Alternate aerodromes include the following:

Take-off alternate. An alternate aerodrome at which an aircraft would be able to land should this become necessary shortly after take-off and it is not possible to use the aerodrome of departure.

En-route alternate. An alternate aerodrome at which an aircraft would be able to land in the event that a diversion becomes necessary while en route.

Destination alternate. An alternate aerodrome at which an aircraft would be able to land should it become either impossible or inadvisable to land at the aerodrome of intended landing.

Note.— *The aerodrome from which a flight departs may also be an en-route or a destination alternate aerodrome for that flight.*

Altimetry system error (ASE). The difference between the altitude indicated by the altimeter display, assuming a correct altimeter barometric setting, and the pressure altitude corresponding to the undisturbed ambient pressure.

Approach and landing operations using instrument approach procedures. Instrument approach and landing operations are classified as follows:

Non-precision approach and landing operations. An instrument approach and landing which utilizes lateral guidance but does not utilize vertical guidance.

Approach and landing operations with vertical guidance. An instrument approach and landing which utilizes lateral and vertical guidance but does not meet the requirements established for precision approach and landing operations.

Precision approach and landing operations. An instrument approach and landing using precision lateral and vertical guidance with minima as determined by the category of operation.

Note.— *Lateral and vertical guidance refers to the guidance provided either by:*

- a) *a ground-based navigation aid; or*
- b) *computer generated navigation data.*

Categories of precision approach and landing operations:

Category I (CAT I) operation. A precision instrument approach and landing with:

- a) a decision height not lower than 60 m (200 ft); and
- b) with either a visibility not less than 800 m or a runway visual range not less than 550 m.

Category II (CAT II) operation. A precision instrument approach and landing with:

- a) a decision height lower than 60 m (200 ft), but not lower than 30 m (100 ft); and
- b) a runway visual range not less than 300 m.

Category IIIA (CAT IIIA) operation. A precision instrument approach and landing with:

- a) a decision height lower than 30 m (100 ft) or no decision height; and
- b) a runway visual range not less than 175 m.

Category IIIB (CAT IIIB) operation. A precision instrument approach and landing with:

- a) a decision height lower than 15 m (50 ft), or no decision height; and
- b) a runway visual range less than 175 m but not less than 50 m.

Category IIIC (CAT IIIC) operation. A precision instrument approach and landing with no decision height and no runway visual range limitations.

Note.— Where decision height (DH) and runway visual range (RVR) fall into different categories of operation, the instrument approach and landing operation would be conducted in accordance with the requirements of the most demanding category (e.g. an operation with a DH in the range of CAT IIIA but with an RVR in the range of CAT IIIB would be considered a CAT IIIB operation or an operation with a DH in the range of CAT II but with an RVR in the range of CAT I would be considered a CAT II operation).

Area navigation (RNAV). A method of navigation which permits aircraft operation on any desired flight path within the coverage of ground- or space-based navigation aids or within the limits of the capability of self-contained aids, or a combination of these.

Note.— Area navigation includes performance-based navigation as well as other operations that do not meet the definition of performance-based navigation.

Cabin crew member. A crew member who performs, in the interest of safety of passengers, duties assigned by the operator or the pilot-in-command of the aircraft, but who shall not act as a flight crew member.

Commercial air transport operation. An aircraft operation involving the transport of passengers, cargo or mail for remuneration or hire.

Configuration deviation list (CDL). A list established by the organization responsible for the type design with the approval of the State of Design which identifies any external parts of an aircraft type which may be missing at the commencement of a flight, and which contains, where necessary, any information on associated operating limitations and performance correction.

Continuing airworthiness. The set of processes by which an aircraft, engine, propeller or part complies with the applicable airworthiness requirements and remains in a condition for safe operation throughout its operating life.

Crew member. A person assigned by an operator to duty on an aircraft during a flight duty period.

Cruise relief pilot. A flight crew member who is assigned to perform pilot tasks during cruise flight, to allow the pilot-in-command or a co-pilot to obtain planned rest.

Cruising level. A level maintained during a significant portion of a flight.

Dangerous goods. Articles or substances which are capable of posing a risk to health, safety, property or the environment and which are shown in the list of dangerous goods in the Technical Instructions or which are classified according to those Instructions.

Note.— Dangerous goods are classified in Annex 18, Chapter 3.

Decision altitude (DA) or decision height (DH). A specified altitude or height in the precision approach or approach with vertical guidance at which a missed approach must be initiated if the required visual reference to continue the approach has not been established.

Note 1.— Decision altitude (DA) is referenced to mean sea level and decision height (DH) is referenced to the threshold elevation.

Note 2.— The required visual reference means that section of the visual aids or of the approach area which should have been in view for sufficient time for the pilot to have made an assessment of the aircraft position and rate of change of position, in relation to the desired flight path. In Category III operations with a decision height the required visual reference is that specified for the particular procedure and operation.

Note 3.— For convenience where both expressions are used they may be written in the form “decision altitude/height” and abbreviated “DA/H”.

Duty. Any task that flight or cabin crew members are required by the operator to perform, including, for example, flight duty, administrative work, training, positioning and standby when it is likely to induce fatigue.

Duty period. A period which starts when a flight or cabin crew member is required by an operator to report for or to commence a duty and ends when that person is free from all duties.

EDTO critical fuel. The fuel quantity necessary to fly to an en-route alternate aerodrome considering, at the most critical point on the route, the most limiting system failure.

Note.— Attachment D contains guidance on EDTO critical fuel scenarios.

EDTO significant system. An aeroplane system whose failure or degradation could adversely affect the safety particular to an EDTO flight, or whose continued functioning is specifically important to the safe flight and landing of an aeroplane during an EDTO diversion.

Emergency locator transmitter (ELT). A generic term describing equipment which broadcast distinctive signals on designated frequencies and, depending on application, may be automatically activated by impact or be manually activated. An ELT may be any of the following:

Automatic fixed ELT (ELT(AF)). An automatically activated ELT which is permanently attached to an aircraft.

Automatic portable ELT (ELT(AP)). An automatically activated ELT which is rigidly attached to an aircraft but readily removable from the aircraft.

Automatic deployable ELT (ELT(AD)). An ELT which is rigidly attached to an aircraft and which is automatically deployed and activated by impact, and, in some cases, also by hydrostatic sensors. Manual deployment is also provided.

Survival ELT (ELT(S)). An ELT which is removable from an aircraft, stowed so as to facilitate its ready use in an emergency, and manually activated by survivors.

Engine. A unit used or intended to be used for aircraft propulsion. It consists of at least those components and equipment necessary for functioning and control, but excludes the propeller/rotors (if applicable).

Enhanced vision system (EVS). A system to display electronic real-time images of the external scene achieved through the use of image sensors.

Extended diversion time operations (EDTO). Any operation by an aeroplane with two or more turbine engines where the diversion time to an en-route alternate aerodrome is greater than the threshold time established by the State of the Operator.

Fatigue. A physiological state of reduced mental or physical performance capability resulting from sleep loss or extended wakefulness, circadian phase, or workload (mental and/or physical activity) that can impair a crew member's alertness and ability to safely operate an aircraft or perform safety-related duties.

Fatigue Risk Management System (FRMS). A data-driven means of continuously monitoring and managing fatigue-related safety risks, based upon scientific principles and knowledge as well as operational experience that aims to ensure relevant personnel are performing at adequate levels of alertness.

Flight crew member. A licensed crew member charged with duties essential to the operation of an aircraft during a flight duty period.

Flight data analysis. A process of analysing recorded flight data in order to improve the safety of flight operations.

Flight duty period. A period which commences when a flight or cabin crew member is required to report for duty that includes a flight or a series of flights and which finishes when the aeroplane finally comes to rest and the engines are shut down at the end of the last flight on which he/she is a crew member.

Flight manual. A manual, associated with the certificate of airworthiness, containing limitations within which the aircraft is to be considered airworthy, and instructions and information necessary to the flight crew members for the safe operation of the aircraft.

Flight operations officer/flight dispatcher. A person designated by the operator to engage in the control and supervision of flight operations, whether licensed or not, suitably qualified in accordance with Annex 1, who supports, briefs and/or assists the pilot-in-command in the safe conduct of the flight.

Flight plan. Specified information provided to air traffic services units, relative to an intended flight or portion of a flight of an aircraft.

Flight recorder. Any type of recorder installed in the aircraft for the purpose of complementing accident/incident investigation.

Flight safety documents system. A set of interrelated documentation established by the operator, compiling and organizing information necessary for flight and ground operations, and comprising, as a minimum, the operations manual and the operator's maintenance control manual.

Flight simulation training device. Any one of the following three types of apparatus in which flight conditions are simulated on the ground:

A flight simulator, which provides an accurate representation of the flight deck of a particular aircraft type to the extent that the mechanical, electrical, electronic, etc. aircraft systems control functions, the normal environment of flight crew members, and the performance and flight characteristics of that type of aircraft are realistically simulated;

A flight procedures trainer, which provides a realistic flight deck environment, and which simulates instrument responses, simple control functions of mechanical, electrical, electronic, etc. aircraft systems, and the performance and flight characteristics of aircraft of a particular class;

A basic instrument flight trainer, which is equipped with appropriate instruments, and which simulates the flight deck environment of an aircraft in flight in instrument flight conditions.

Flight time — aeroplanes. The total time from the moment an aeroplane first moves for the purpose of taking off until the moment it finally comes to rest at the end of the flight.

Note.— Flight time as here defined is synonymous with the term “block to block” time or “chock to chock” time in general usage which is measured from the time an aeroplane first moves for the purpose of taking off until it finally stops at the end of the flight.

General aviation operation. An aircraft operation other than a commercial air transport operation or an aerial work operation.

Ground handling. Services necessary for an aircraft's arrival at, and departure from, an airport, other than air traffic services.

Head-up display (HUD). A display system that presents flight information into the pilot's forward external field of view.

Human Factors principles. Principles which apply to aeronautical design, certification, training, operations and maintenance and which seek safe interface between the human and other system components by proper consideration to human performance.

Human performance. Human capabilities and limitations which have an impact on the safety and efficiency of aeronautical operations.

Instrument meteorological conditions (IMC). Meteorological conditions expressed in terms of visibility, distance from cloud, and ceiling*, less than the minima specified for visual meteorological conditions.

Note.— The specified minima for visual meteorological conditions are contained in Chapter 4 of Annex 2.

Isolated aerodrome. A destination aerodrome for which there is no destination alternate aerodrome suitable for a given aeroplane type.

Landing distance available (LDA). The length of runway which is declared available and suitable for the ground run of an aeroplane landing.

Large aeroplane. An aeroplane of a maximum certificated take-off mass of over 5 700 kg.

Maintenance. The performance of tasks required to ensure the continuing airworthiness of an aircraft, including any one or combination of overhaul, inspection, replacement, defect rectification, and the embodiment of a modification or repair.

Maintenance organization's procedures manual. A document endorsed by the head of the maintenance organization which details the maintenance organization's structure and management responsibilities, scope of work, description of facilities, maintenance procedures and quality assurance or inspection systems.

Maintenance programme. A document which describes the specific scheduled maintenance tasks and their frequency of completion and related procedures, such as a reliability programme, necessary for the safe operation of those aircraft to which it applies.

Maintenance release. A document which contains a certification confirming that the maintenance work to which it relates has been completed in a satisfactory manner, either in accordance with the approved data and the procedures described in the maintenance organization's procedures manual or under an equivalent system.

Master minimum equipment list (MMEL). A list established for a particular aircraft type by the organization responsible for the type design with the approval of the State of Design containing items, one or more of which is permitted to be unserviceable at the commencement of a flight. The MMEL may be associated with special operating conditions, limitations or procedures.

Maximum diversion time. Maximum allowable range, expressed in time, from a point on a route to an en-route alternate aerodrome.

Maximum mass. Maximum certificated take-off mass.

* As defined in Annex 2.

Minimum descent altitude (MDA) or minimum descent height (MDH). A specified altitude or height in a non-precision approach or circling approach below which descent must not be made without the required visual reference.

Note 1.— Minimum descent altitude (MDA) is referenced to mean sea level and minimum descent height (MDH) is referenced to the aerodrome elevation or to the threshold elevation if that is more than 2 m (7 ft) below the aerodrome elevation. A minimum descent height for a circling approach is referenced to the aerodrome elevation.

Note 2.— The required visual reference means that section of the visual aids or of the approach area which should have been in view for sufficient time for the pilot to have made an assessment of the aircraft position and rate of change of position, in relation to the desired flight path. In the case of a circling approach the required visual reference is the runway environment.

Note 3.— For convenience when both expressions are used they may be written in the form “minimum descent altitude/height” and abbreviated “MDA/H”.

Minimum equipment list (MEL). A list which provides for the operation of aircraft, subject to specified conditions, with particular equipment inoperative, prepared by an operator in conformity with, or more restrictive than, the MMEL established for the aircraft type.

Navigation specification. A set of aircraft and flight crew requirements needed to support performance-based navigation operations within a defined airspace. There are two kinds of navigation specifications:

Required navigation performance (RNP) specification. A navigation specification based on area navigation that includes the requirement for performance monitoring and alerting, designated by the prefix RNP, e.g. RNP 4, RNP APCH.

Area navigation (RNAV) specification. A navigation specification based on area navigation that does not include the requirement for performance monitoring and alerting, designated by the prefix RNAV, e.g. RNAV 5, RNAV 1.

Note 1.— The Performance-based Navigation (PBN) Manual (Doc 9613), Volume II, contains detailed guidance on navigation specifications.

Note 2.— The term RNP, previously defined as “a statement of the navigation performance necessary for operation within a defined airspace”, has been removed from this Annex as the concept of RNP has been overtaken by the concept of PBN. The term RNP in this Annex is now solely used in the context of navigation specifications that require performance monitoring and alerting, e.g. RNP 4 refers to the aircraft and operating requirements, including a 4 NM lateral performance with on-board performance monitoring and alerting that are detailed in Doc 9613.

Night. The hours between the end of evening civil twilight and the beginning of morning civil twilight or such other period between sunset and sunrise, as may be prescribed by the appropriate authority.

Note.— Civil twilight ends in the evening when the centre of the sun’s disc is 6 degrees below the horizon and begins in the morning when the centre of the sun’s disc is 6 degrees below the horizon.

Obstacle clearance altitude (OCA) or obstacle clearance height (OCH). The lowest altitude or the lowest height above the elevation of the relevant runway threshold or the aerodrome elevation as applicable, used in establishing compliance with appropriate obstacle clearance criteria.

Note 1.— Obstacle clearance altitude is referenced to mean sea level and obstacle clearance height is referenced to the threshold elevation or in the case of non-precision approaches to the aerodrome elevation or the threshold elevation if that is more than 2 m (7 ft) below the aerodrome elevation. An obstacle clearance height for a circling approach is referenced to the aerodrome elevation.

Note 2.— For convenience when both expressions are used they may be written in the form “obstacle clearance altitude/height” and abbreviated “OCA/H”.

Operational control. The exercise of authority over the initiation, continuation, diversion or termination of a flight in the interest of the safety of the aircraft and the regularity and efficiency of the flight.

Operational flight plan. The operator's plan for the safe conduct of the flight based on considerations of aeroplane performance, other operating limitations and relevant expected conditions on the route to be followed and at the aerodromes concerned.

Operations manual. A manual containing procedures, instructions and guidance for use by operational personnel in the execution of their duties.

Operations specifications. The authorizations, conditions and limitations associated with the air operator certificate and subject to the conditions in the operations manual.

Operator. A person, organization or enterprise engaged in or offering to engage in an aircraft operation.

Operator's maintenance control manual. A document which describes the operator's procedures necessary to ensure that all scheduled and unscheduled maintenance is performed on the operator's aircraft on time and in a controlled and satisfactory manner.

Performance-based navigation (PBN). Area navigation based on performance requirements for aircraft operating along an ATS route, on an instrument approach procedure or in a designated airspace.

Note.— Performance requirements are expressed in navigation specifications (RNAV specification, RNP specification) in terms of accuracy, integrity, continuity, availability and functionality needed for the proposed operation in the context of a particular airspace concept.

Pilot-in-command. The pilot designated by the operator, or in the case of general aviation, the owner, as being in command and charged with the safe conduct of a flight.

Point of no return. The last possible geographic point at which an aeroplane can proceed to the destination aerodrome as well as to an available en-route alternate aerodrome for a given flight.

Pressure-altitude. An atmospheric pressure expressed in terms of altitude which corresponds to that pressure in the Standard Atmosphere*.

Psychoactive substances. Alcohol, opioids, cannabinoids, sedatives and hypnotics, cocaine, other psychostimulants, hallucinogens, and volatile solvents, whereas coffee and tobacco are excluded.

Repair. The restoration of an aeronautical product to an airworthy condition to ensure that the aircraft continues to comply with the design aspects of the appropriate airworthiness requirements used for the issuance of the type certificate for the respective aircraft type, after it has been damaged or subjected to wear.

Required communication performance (RCP). A statement of the performance requirements for operational communication in support of specific ATM functions.

Required communication performance type (RCP type). A label (e.g. RCP 240) that represents the values assigned to RCP parameters for communication transaction time, continuity, availability and integrity.

Rest period. A continuous and defined period of time, subsequent to and/or prior to duty, during which flight or cabin crew members are free of all duties.

* As defined in Annex 8.

Runway visual range (RVR). The range over which the pilot of an aircraft on the centre line of a runway can see the runway surface markings or the lights delineating the runway or identifying its centre line.

Safe forced landing. Unavoidable landing or ditching with a reasonable expectancy of no injuries to persons in the aircraft or on the surface.

Safety management system. A systematic approach to managing safety, including the necessary organizational structures, accountabilities, policies and procedures.

Small aeroplane. An aeroplane of a maximum certificated take-off mass of 5 700 kg or less.

State of Registry. The State on whose register the aircraft is entered.

Note.— In the case of the registration of aircraft of an international operating agency on other than a national basis, the States constituting the agency are jointly and severally bound to assume the obligations which, under the Chicago Convention, attach to a State of Registry. See, in this regard, the Council Resolution of 14 December 1967 on Nationality and Registration of Aircraft Operated by International Operating Agencies which can be found in Policy and Guidance Material on the Economic Regulation of International Air Transport (Doc 9587).

State of the Operator. The State in which the operator's principal place of business is located or, if there is no such place of business, the operator's permanent residence.

State safety programme. An integrated set of regulations and activities aimed at improving safety.

Target level of safety (TLS). A generic term representing the level of risk which is considered acceptable in particular circumstances.

Threshold time. The range, expressed in time, established by the State of the Operator, to an en-route alternate aerodrome, whereby any time beyond requires an EDTO approval from the State of the Operator.

Total vertical error (TVE). The vertical geometric difference between the actual pressure altitude flown by an aircraft and its assigned pressure altitude (flight level).

Visual meteorological conditions (VMC). Meteorological conditions expressed in terms of visibility, distance from cloud, and ceiling*, equal to or better than specified minima.

Note.— The specified minima are contained in Chapter 4 of Annex 2.

* As defined in Annex 2.

CHAPTER 2. APPLICABILITY

The Standards and Recommended Practices contained in Annex 6, Part I, shall be applicable to the operation of aeroplanes by operators authorized to conduct international commercial air transport operations.

Note 1.— Standards and Recommended Practices applicable to international general aviation operations with aeroplanes are to be found in Annex 6, Part II.

Note 2.— Standards and Recommended Practices applicable to international commercial air transport operations or international general aviation operations with helicopters are to be found in Annex 6, Part III.

CHAPTER 3. GENERAL

Note 1.— Although the Convention on International Civil Aviation allocates to the State of Registry certain functions which that State is entitled to discharge, or obligated to discharge, as the case may be, the Assembly recognized, in Resolution A23-13 that the State of Registry may be unable to fulfil its responsibilities adequately in instances where aircraft are leased, chartered or interchanged — in particular without crew — by an operator of another State and that the Convention may not adequately specify the rights and obligations of the State of an operator in such instances until such time as Article 83 bis of the Convention enters into force. Accordingly, the Council urged that if, in the above-mentioned instances, the State of Registry finds itself unable to discharge adequately the functions allocated to it by the Convention, it delegate to the State of the Operator, subject to acceptance by the latter State, those functions of the State of Registry that can more adequately be discharged by the State of the Operator. It was understood that pending entry into force of Article 83 bis of the Convention the foregoing action would only be a matter of practical convenience and would not affect either the provisions of the Chicago Convention prescribing the duties of the State of Registry or any third State. However, as Article 83 bis of the Convention entered into force on 20 June 1997, such transfer agreements will have effect in respect of Contracting States which have ratified the related Protocol (Doc 9318) upon fulfilment of the conditions established in Article 83 bis.

Note 2.— In the case of international operations effected jointly with aeroplanes not all of which are registered in the same Contracting State, nothing in this Part prevents the States concerned entering into an agreement for the joint exercise of the functions placed upon the State of Registry by the provisions of the relevant Annexes.

3.1 Compliance with laws, regulations and procedures

3.1.1 An operator shall ensure that all employees when abroad know that they must comply with the laws, regulations and procedures of those States in which operations are conducted.

3.1.2 An operator shall ensure that all pilots are familiar with the laws, regulations and procedures, pertinent to the performance of their duties, prescribed for the areas to be traversed, the aerodromes to be used and the air navigation facilities relating thereto. The operator shall ensure that other members of the flight crew are familiar with such of these laws, regulations and procedures as are pertinent to the performance of their respective duties in the operation of the aeroplane.

Note.— Information for pilots and flight operations personnel on flight procedure parameters and operational procedures is contained in PANS-OPS (Doc 8168), Volume I. Criteria for the construction of visual and instrument flight procedures are contained in PANS-OPS (Doc 8168), Volume II. Obstacle clearance criteria and procedures used in certain States may differ from PANS-OPS, and knowledge of these differences is important for safety reasons.

3.1.3 An operator or a designated representative shall have responsibility for operational control.

Note.— The rights and obligations of a State in respect to the operation of aeroplanes registered in that State are not affected by this provision.

3.1.4 Responsibility for operational control shall be delegated only to the pilot-in-command and to a flight operations officer/flight dispatcher if an operator's approved method of control and supervision of flight operations requires the use of flight operations officer/flight dispatcher personnel.

Note.— Guidance on the operational control organization and the role of the flight operations officer/flight dispatcher is contained in the Manual of Procedures for Operations Inspection, Certification and Continued Surveillance (Doc 8335).

Detailed guidance on the authorization, duties and responsibilities of the flight operations officer/flight dispatcher is contained in the Preparation of an Operations Manual (Doc 9376). The requirements for age, skill, knowledge and experience for licensed flight operations officers/flight dispatchers are contained in Annex 1.

3.1.5 If an emergency situation which endangers the safety of the aeroplane or persons becomes known first to the flight operations officer/flight dispatcher, action by that person in accordance with 4.6.2 shall include, where necessary, notification to the appropriate authorities of the nature of the situation without delay, and requests for assistance if required.

3.1.6 If an emergency situation which endangers the safety of the aeroplane or persons necessitates the taking of action which involves a violation of local regulations or procedures, the pilot-in-command shall notify the appropriate local authority without delay. If required by the State in which the incident occurs, the pilot-in-command shall submit a report on any such violation to the appropriate authority of such State; in that event, the pilot-in-command shall also submit a copy of it to the State of the Operator. Such reports shall be submitted as soon as possible and normally within ten days.

3.1.7 Operators shall ensure that pilots-in-command have available on board the aeroplane all the essential information concerning the search and rescue services in the area over which the aeroplane will be flown.

Note.— This information may be made available to the pilot by means of the operations manual or such other means as is considered appropriate.

3.1.8 Operators shall ensure that flight crew members demonstrate the ability to speak and understand the language used for radiotelephony communications as specified in Annex 1.

3.2 Compliance by a foreign operator with laws, regulations and procedures of a State

3.2.1 When a State identifies a case of non-compliance or suspected non-compliance by a foreign operator with laws, regulations and procedures applicable within that State's territory, or a similar serious safety issue with that operator, that State shall immediately notify the operator and, if the issue warrants it, the State of the Operator. Where the State of the Operator and the State of Registry are different, such notification shall also be made to the State of Registry, if the issue falls within the responsibilities of that State and warrants a notification.

3.2.2 In the case of notification to States as specified in 3.2.1, if the issue and its resolution warrant it, the State in which the operation is conducted shall engage in consultations with the State of the Operator and the State of Registry, as applicable, concerning the safety standards maintained by the operator.

Note.— The Manual of Procedures for Operations Inspection, Certification and Continued Surveillance (Doc 8335) provides guidance on the surveillance of operations by foreign operators. The manual also contains guidance on the consultations and related activities, as specified in 3.2.2, including the ICAO model clause on aviation safety, which, if included in a bilateral or multilateral agreement, provides for consultations among States, when safety issues are identified by any of the parties to a bilateral or multilateral agreement on air services.

3.3 Safety management

3.3.1 States shall establish a State safety programme in order to achieve an acceptable level of safety in civil aviation.

Note.— A framework for the implementation and maintenance of a State safety programme is contained in Attachment I, and guidance on a State safety programme is contained in the Safety Management Manual (SMM) (Doc 9859).

3.3.2 The acceptable level of safety to be achieved shall be established by the State.

Note.— Guidance on defining an acceptable level of safety is contained in the Safety Management Manual (SMM) (Doc 9859).

3.3.3 States shall require, as part of their State safety programme, that an operator implement a safety management system acceptable to the State of the Operator that, as a minimum:

- a) identifies safety hazards;
- b) ensures the implementation of remedial action necessary to maintain agreed safety performance;
- c) provides for continuous monitoring and regular assessment of the safety performance; and
- d) aims at a continuous improvement of the overall performance of the safety management system.

Note.— Guidance on defining safety performance is contained in the Safety Management Manual (SMM) (Doc 9859).

3.3.4 A safety management system shall clearly define lines of safety accountability throughout the operator's organization, including a direct accountability for safety on the part of senior management.

Note.— The framework for the implementation and maintenance of a safety management system is contained in Appendix 7. Guidance on safety management systems is contained in the Safety Management Manual (SMM) (Doc 9859).

3.3.5 **Recommendation.**— *An operator of an aeroplane of a certificated take-off mass in excess of 20 000 kg should establish and maintain a flight data analysis programme as part of its safety management system.*

3.3.6 An operator of an aeroplane of a maximum certificated take-off mass in excess of 27 000 kg shall establish and maintain a flight data analysis programme as part of its safety management system.

Note.— An operator may contract the operation of a flight data analysis programme to another party while retaining overall responsibility for the maintenance of such a programme.

3.3.7 A flight data analysis programme shall be non-punitive and contain adequate safeguards to protect the source(s) of the data.

Note 1.— Guidance on flight data analysis programmes is contained in the Manual on Flight Data Analysis Programmes (FDAP) (Doc 10000).

Note 2.— Legal guidance for the protection of information from safety data collection and processing systems is contained in Annex 13, Attachment E.

3.3.8 An operator shall establish a flight safety documents system, for the use and guidance of operational personnel, as part of its safety management system.

Note.— Guidance on the development and organization of a flight safety documents system is provided in Attachment G.

3.4 Dangerous goods

Note 1.— Provisions for carriage of dangerous goods are contained in Annex 18.

Note 2.— Article 35 of the Convention refers to certain classes of cargo restrictions.

3.5 Use of psychoactive substances

Note.— Provisions concerning the use of psychoactive substances are contained in Annex 1, 1.2.7 and Annex 2, 2.5.

CHAPTER 4. FLIGHT OPERATIONS

4.1 Operating facilities

4.1.1 An operator shall ensure that a flight will not be commenced unless it has been ascertained by every reasonable means available that the ground and/or water facilities available and directly required on such flight, for the safe operation of the aeroplane and the protection of the passengers, are adequate for the type of operation under which the flight is to be conducted and are adequately operated for this purpose.

Note.— “Reasonable means” in this Standard is intended to denote the use, at the point of departure, of information available to the operator either through official information published by the aeronautical information services or readily obtainable from other sources.

4.1.2 An operator shall ensure that any inadequacy of facilities observed in the course of operations is reported to the authority responsible for them, without undue delay.

4.1.3 Subject to their published conditions of use, aerodromes and their facilities shall be kept continuously available for flight operations during their published hours of operations, irrespective of weather conditions.

4.1.4 An operator shall, as part of its safety management system, assess the level of rescue and fire fighting service (RFFS) protection available at any aerodrome intended to be specified in the operational flight plan in order to ensure that an acceptable level of protection is available for the aeroplane intended to be used.

4.1.5 Information related to the level of RFFS protection that is deemed acceptable by the operator shall be contained in the operations manual.

Note 1.— Attachment K contains guidance on assessing an acceptable level of RFFS protection at aerodromes.

Note 2.— It is not intended that this guidance limit or regulate the operation of an aerodrome. The assessment performed by the operator does not in any way affect the RFFS requirements of Annex 14, Volume I, for aerodromes.

4.2 Operational certification and supervision

4.2.1 The air operator certificate

4.2.1.1 An operator shall not engage in commercial air transport operations unless in possession of a valid air operator certificate issued by the State of the Operator.

4.2.1.2 The air operator certificate shall authorize the operator to conduct commercial air transport operations in accordance with the operations specifications.

Note.— Provisions for the content of the air operator certificate and its associated operations specifications are contained in 4.2.1.5 and 4.2.1.6.

4.2.1.3 The issue of an air operator certificate by the State of the Operator shall be dependent upon the operator demonstrating an adequate organization, method of control and supervision of flight operations, training programme as well as ground handling and maintenance arrangements consistent with the nature and extent of the operations specified.

Note.— Attachment E contains guidance on the issue of an air operator certificate.

4.2.1.4 The continued validity of an air operator certificate shall depend upon the operator maintaining the requirements of 4.2.1.3 under the supervision of the State of the Operator.

4.2.1.5 The air operator certificate shall contain at least the following information and, from 1 January 2010, shall follow the layout of Appendix 6, paragraph 2:

- a) the State of the Operator and the issuing authority;
- b) the air operator certificate number and its expiration date;
- c) the operator name, trading name (if different) and address of the principal place of business;
- d) the date of issue and the name, signature and title of the authority representative; and
- e) the location, in a controlled document carried on board, where the contact details of operational management can be found.

4.2.1.6 The operations specifications associated with the air operator certificate shall contain at least the information listed in Appendix 6, paragraph 3, and, from 1 January 2010, shall follow the layout of Appendix 6, paragraph 3.

Note.— Attachment E, paragraph 3.2.2, contains additional information that may be listed in the operations specifications associated with the air operator certificate.

4.2.1.7 Air operator certificates and their associated operations specifications first issued from 20 November 2008 shall follow the layouts of Appendix 6, paragraphs 2 and 3.

4.2.1.8 The State of the Operator shall establish a system for both the certification and the continued surveillance of the operator in accordance with Appendix 5 to ensure that the required standards of operations established in 4.2 are maintained.

4.2.2 Surveillance of operations by a foreign operator

4.2.2.1 Contracting States shall recognize as valid an air operator certificate issued by another Contracting State, provided that the requirements under which the certificate was issued are at least equal to the applicable Standards specified in this Annex.

4.2.2.2 States shall establish a programme with procedures for the surveillance of operations in their territory by a foreign operator and for taking appropriate action when necessary to preserve safety.

4.2.2.3 An operator shall meet and maintain the requirements established by the States in which the operations are conducted.

Note.— Guidance on the surveillance of operations by foreign operators may be found in the Manual of Procedures for Operations Inspection, Certification and Continued Surveillance (Doc 8335).

4.2.3 Operations manual

4.2.3.1 An operator shall provide, for the use and guidance of operations personnel concerned, an operations manual in accordance with Appendix 2. The operations manual shall be amended or revised as is necessary to ensure that the information contained therein is kept up to date. All such amendments or revisions shall be issued to all personnel that are required to use this manual.

4.2.3.2 The State of the Operator shall establish a requirement for the operator to provide a copy of the operations manual together with all amendments and/or revisions, for review and acceptance and, where required, approval. The operator shall incorporate in the operations manual such mandatory material as the State of the Operator may require.

Note 1.— Requirements for the organization and content of an operations manual are provided in Appendix 2.

Note 2.— Specific items in the operations manual require the approval of the State of the Operator in accordance with the Standards in 4.2.8, 6.1.3, 9.3.1, 12.4 and 13.4.1.

4.2.4 Operating instructions — general

4.2.4.1 An operator shall ensure that all operations personnel are properly instructed in their particular duties and responsibilities and the relationship of such duties to the operation as a whole.

4.2.4.2 An aeroplane shall not be taxied on the movement area of an aerodrome unless the person at the controls:

- a) has been duly authorized by the operator or a designated agent;
- b) is fully competent to taxi the aeroplane;
- c) is qualified to use the radiotelephone; and
- d) has received instruction from a competent person in respect of aerodrome layout, routes, signs, marking, lights, air traffic control (ATC) signals and instructions, phraseology and procedures, and is able to conform to the operational standards required for safe aeroplane movement at the aerodrome.

4.2.4.3 **Recommendation.**— *The operator should issue operating instructions and provide information on aeroplane climb performance with all engines operating to enable the pilot-in-command to determine the climb gradient that can be achieved during the departure phase for the existing take-off conditions and intended take-off technique. This information should be included in the operations manual.*

4.2.5 In-flight simulation of emergency situations

An operator shall ensure that when passengers or cargo are being carried, no emergency or abnormal situations shall be simulated.

4.2.6 Checklists

The checklists provided in accordance with 6.1.4 shall be used by flight crews prior to, during and after all phases of operations, and in emergency, to ensure compliance with the operating procedures contained in the aircraft operating manual and the aeroplane flight manual or other documents associated with the certificate of airworthiness and otherwise in the operations manual, are followed. The design and utilization of checklists shall observe Human Factors principles.

Note.— Guidance material on the application of Human Factors principles can be found in the Human Factors Training Manual (Doc 9683).

4.2.7 Minimum flight altitudes

4.2.7.1 An operator shall be permitted to establish minimum flight altitudes for those routes flown for which minimum flight altitudes have been established by the State flown over or the responsible State, provided that they shall not be less than those established by that State.

4.2.7.2 An operator shall specify the method by which it is intended to determine minimum flight altitudes for operations conducted over routes for which minimum flight altitudes have not been established by the State flown over or the responsible State, and shall include this method in the operations manual. The minimum flight altitudes determined in accordance with the above method shall not be lower than specified in Annex 2.

4.2.7.3 **Recommendation.**— *The method for establishing the minimum flight altitudes should be approved by the State of the Operator.*

4.2.7.4 **Recommendation.**— *The State of the Operator should approve such method only after careful consideration of the probable effects of the following factors on the safety of the operation in question:*

- a) *the accuracy and reliability with which the position of the aeroplane can be determined;*
- b) *the inaccuracies in the indications of the altimeters used;*
- c) *the characteristics of the terrain (e.g. sudden changes in the elevation);*
- d) *the probability of encountering unfavourable meteorological conditions (e.g. severe turbulence and descending air currents);*
- e) *possible inaccuracies in aeronautical charts; and*
- f) *airspace restrictions.*

4.2.8 Aerodrome operating minima

4.2.8.1 The State of the Operator shall require that the operator establish aerodrome operating minima for each aerodrome to be used in operations and shall approve the method of determination of such minima. Such minima shall not be lower than any that may be established for such aerodromes by the State in which the aerodrome is located, except when specifically approved by that State.

Note 1.— *This Standard does not require the State in which the aerodrome is located to establish aerodrome operating minima.*

Note 2.— *The use of head-up displays (HUD) or enhanced vision systems (EVS) may allow operations with lower visibilities than normally associated with the aerodrome operating minima.*

4.2.8.2 The State of the Operator shall require that in establishing the aerodrome operating minima which will apply to any particular operation, full account shall be taken of:

- a) the type, performance and handling characteristics of the aeroplane;

- b) the composition of the flight crew, their competence and experience;
- c) the dimensions and characteristics of the runways which may be selected for use;
- d) the adequacy and performance of the available visual and non-visual ground aids;
- e) the equipment available on the aeroplane for the purpose of navigation and/or control of the flight path during the approach to landing and the missed approach;
- f) the obstacles in the approach and missed approach areas and the obstacle clearance altitude/height for the instrument approach procedures;
- g) the means used to determine and report meteorological conditions; and
- h) the obstacles in the climb-out areas and necessary clearance margins.

Note.— *Guidance on the establishment of aerodrome operating minima is contained in the Manual of All-Weather Operations (Doc 9365).*

4.2.8.3 Category II and Category III instrument approach and landing operations shall not be authorized unless RVR information is provided.

4.2.8.4 **Recommendation.**— *For instrument approach and landing operations, aerodrome operating minima below 800 m visibility should not be authorized unless RVR information is provided.*

4.2.9 Threshold crossing height for precision approaches

An operator shall establish operational procedures designed to ensure that an aeroplane being used to conduct precision approaches crosses the threshold by a safe margin, with the aeroplane in the landing configuration and attitude.

4.2.10 Fuel and oil records

4.2.10.1 An operator shall maintain fuel records to enable the State of the Operator to ascertain that, for each flight, the requirements of 4.3.6 and 4.3.7.1 have been complied with.

4.2.10.2 An operator shall maintain oil records to enable the State of the Operator to ascertain that trends for oil consumption are such that an aeroplane has sufficient oil to complete each flight.

4.2.10.3 Fuel and oil records shall be retained by the operator for a period of three months.

4.2.11 Crew

4.2.11.1 *Pilot-in-command.* For each flight, the operator shall designate one pilot to act as pilot-in-command.

4.2.11.2 For each flight of an aeroplane above 15 000 m (49 000 ft), the operator shall maintain records so that the total cosmic radiation dose received by each crew member over a period of 12 consecutive months can be determined.

Note.— *Guidance on the maintenance of cumulative radiation records is given in Circular 126 — Guidance Material on SST Aircraft Operations.*

4.2.12 Passengers

4.2.12.1 An operator shall ensure that passengers are made familiar with the location and use of:

- a) seat belts;
- b) emergency exits;
- c) life jackets, if the carriage of life jackets is prescribed;
- d) oxygen dispensing equipment, if the provision of oxygen for the use of passengers is prescribed; and
- e) other emergency equipment provided for individual use, including passenger emergency briefing cards.

4.2.12.2 The operator shall inform the passengers of the location and general manner of use of the principal emergency equipment carried for collective use.

4.2.12.3 In an emergency during flight, passengers shall be instructed in such emergency action as may be appropriate to the circumstances.

4.2.12.4 The operator shall ensure that, during take-off and landing and whenever considered necessary by reason of turbulence or any emergency occurring during flight, all passengers on board an aeroplane shall be secured in their seats by means of the seat belts or harnesses provided.

4.3 Flight preparation

4.3.1 A flight shall not be commenced until flight preparation forms have been completed certifying that the pilot-in-command is satisfied that:

- a) the aeroplane is airworthy;
- b) the instruments and equipment prescribed in Chapter 6, for the particular type of operation to be undertaken, are installed and are sufficient for the flight;
- c) a maintenance release as prescribed in 8.8 has been issued in respect of the aeroplane;
- d) the mass of the aeroplane and centre of gravity location are such that the flight can be conducted safely, taking into account the flight conditions expected;
- e) any load carried is properly distributed and safely secured;
- f) a check has been completed indicating that the operating limitations of Chapter 5 can be complied with for the flight to be undertaken; and
- g) the Standards of 4.3.3 relating to operational flight planning have been complied with.

4.3.2 Completed flight preparation forms shall be kept by an operator for a period of three months.

4.3.3 Operational flight planning

4.3.3.1 An operational flight plan shall be completed for every intended flight. The operational flight plan shall be approved and signed by the pilot-in-command and, where applicable, signed by the flight operations officer/flight dispatcher, and a copy shall be filed with the operator or a designated agent, or, if these procedures are not possible, it shall be left with the aerodrome authority or on record in a suitable place at the point of departure.

Note.— The duties of a flight operations officer/flight dispatcher are contained in 4.6.

4.3.3.2 The operations manual must describe the content and use of the operational flight plan.

4.3.4 Alternate aerodromes

4.3.4.1 Take-off alternate aerodrome

4.3.4.1.1 A take-off alternate aerodrome shall be selected and specified in the operational flight plan if either the meteorological conditions at the aerodrome of departure are below the operator's established aerodrome landing minima for that operation or if it would not be possible to return to the aerodrome of departure for other reasons.

4.3.4.1.2 The take-off alternate aerodrome shall be located within the following flight time from the aerodrome of departure:

- a) for aeroplanes with two engines, one hour of flight time at a one-engine-inoperative cruising speed, determined from the aircraft operating manual, calculated in ISA and still-air conditions using the actual take-off mass; or
- b) for aeroplanes with three or more engines, two hours of flight time at an all engines operating cruising speed, determined from the aircraft operating manual, calculated in ISA and still-air conditions using the actual take-off mass; or
- c) for aeroplanes engaged in extended diversion time operations (EDTO) where an alternate aerodrome meeting the distance criteria of a) or b) is not available, the first available alternate aerodrome located within the distance of the operator's approved maximum diversion time considering the actual take-off mass.

4.3.4.1.3 For an aerodrome to be selected as a take-off alternate the available information shall indicate that, at the estimated time of use, the conditions will be at or above the operator's established aerodrome operating minima for that operation.

4.3.4.2 En-route alternate aerodromes

En-route alternate aerodromes, required by 4.7 for extended diversion time operations by aeroplanes with two turbine engines, shall be selected and specified in the operational and air traffic services (ATS) flight plans.

4.3.4.3 Destination alternate aerodromes

4.3.4.3.1 For a flight to be conducted in accordance with the instrument flight rules, at least one destination alternate aerodrome shall be selected and specified in the operational and ATS flight plans, unless:

- a) the duration of the flight from the departure aerodrome, or from the point of in-flight re-planning, to the destination aerodrome is such that, taking into account all meteorological conditions and operational information relevant to the flight, at the estimated time of use, a reasonable certainty exists that:

- 1) the approach and landing may be made under visual meteorological conditions; and
 - 2) separate runways are usable at the estimated time of use of the destination aerodrome with at least one runway having an operational instrument approach procedure; or
- b) the aerodrome is isolated. Operations into isolated aerodromes do not require the selection of a destination alternate aerodrome(s) and shall be planned in accordance with 4.3.6.3 d) 4);
- 1) for each flight into an isolated aerodrome a point of no return shall be determined; and
 - 2) a flight to be conducted to an isolated aerodrome shall not be continued past the point of no return unless a current assessment of meteorological conditions, traffic and other operational conditions indicate that a safe landing can be made at the estimated time of use.

Note 1.— Separate runways are two or more runways at the same aerodrome configured such that if one runway is closed, operations to the other runway(s) can be conducted.

Note 2.— Guidance on planning operations to isolated aerodromes is contained in the Flight Planning and Fuel Management Manual (Doc 9976).

4.3.4.3.2 Two destination alternate aerodromes shall be selected and specified in the operational and ATS flight plans when, for the destination aerodrome:

- a) meteorological conditions at the estimated time of use will be below the operator's established aerodrome operating minima for that operation; or
- b) meteorological information is not available.

4.3.4.4 Notwithstanding the provisions in 4.3.4.1, 4.3.4.2 and 4.3.4.3, the State of the Operator may, based on the results of a specific safety risk assessment conducted by the operator which demonstrates how an equivalent level of safety will be maintained, approve operational variations to alternate aerodrome selection criteria. The specific safety risk assessment shall include at least the:

- a) capabilities of the operator;
- b) overall capability of the aeroplane and its systems;
- c) available aerodrome technologies, capabilities and infrastructure;
- d) quality and reliability of meteorological information;
- e) identified hazards and safety risks associated with each alternate aerodrome variation; and
- f) specific mitigation measures.

Note.— Guidance on performing a safety risk assessment and on determining variations, including examples of variations, is contained in the Flight Planning and Fuel Management Manual (Doc 9976) and the Safety Management Manual (SMM) (Doc 9859).

4.3.5 Meteorological conditions

4.3.5.1 A flight to be conducted in accordance with the visual flight rules shall not be commenced unless current meteorological reports or a combination of current reports and forecasts indicate that the meteorological conditions along the route or that part of the route to be flown under the visual flight rules will, at the appropriate time, be such as to enable compliance with these rules.

4.3.5.2 A flight to be conducted in accordance with the instrument flight rules shall not:

- a) take off from the departure aerodrome unless the meteorological conditions, at the time of use, are at or above the operator's established aerodrome operating minima for that operation; and
- b) take off or continue beyond the point of in-flight re-planning unless at the aerodrome of intended landing or at each alternate aerodrome to be selected in compliance with 4.3.4, current meteorological reports or a combination of current reports and forecasts indicate that the meteorological conditions will be, at the estimated time of use, at or above the operator's established aerodrome operating minima for that operation.

4.3.5.3 To ensure that an adequate margin of safety is observed in determining whether or not an approach and landing can be safely carried out at each alternate aerodrome, the operator shall specify appropriate incremental values for height of cloud base and visibility, acceptable to the State of the Operator, to be added to the operator's established aerodrome operating minima.

Note.— Guidance on the selection of these incremental values is contained in the Flight Planning and Fuel Management Manual (Doc 9976).

4.3.5.4 The State of the Operator shall approve a margin of time established by the operator for the estimated time of use of an aerodrome.

Note.— Guidance on establishing an appropriate margin of time for the estimated time of use of an aerodrome is contained in the Flight Planning and Fuel Management Manual (Doc 9976).

4.3.5.5 A flight to be operated in known or expected icing conditions shall not be commenced unless the aeroplane is certificated and equipped to cope with such conditions.

4.3.5.6 A flight to be planned or expected to operate in suspected or known ground icing conditions shall not take off unless the aeroplane has been inspected for icing and, if necessary, has been given appropriate de-icing/anti-icing treatment. Accumulation of ice or other naturally occurring contaminants shall be removed so that the aeroplane is kept in an airworthy condition prior to take-off.

Note.— Guidance material is given in the Manual of Aircraft Ground De-icing/Anti-icing Operations (Doc 9640).

4.3.6 Fuel requirements

4.3.6.1 An aeroplane shall carry a sufficient amount of usable fuel to complete the planned flight safely and to allow for deviations from the planned operation.

4.3.6.2 The amount of usable fuel to be carried shall, as a minimum, be based on:

- a) the following data:
 - 1) current aeroplane-specific data derived from a fuel consumption monitoring system, if available; or

- 2) if current aeroplane-specific data are not available, data provided by the aeroplane manufacturer; and
- b) the operating conditions for the planned flight including:
 - 1) anticipated aeroplane mass;
 - 2) Notices to Airmen;
 - 3) current meteorological reports or a combination of current reports and forecasts;
 - 4) air traffic services procedures, restrictions and anticipated delays; and
 - 5) the effects of deferred maintenance items and/or configuration deviations.

4.3.6.3 The pre-flight calculation of usable fuel required shall include:

- a) *taxi fuel*, which shall be the amount of fuel expected to be consumed before take-off;
- b) *trip fuel*, which shall be the amount of fuel required to enable the aeroplane to fly from take-off, or the point of in-flight re-planning, until landing at the destination aerodrome taking into account the operating conditions of 4.3.6.2 b);
- c) *contingency fuel*, which shall be the amount of fuel required to compensate for unforeseen factors. It shall be five per cent of the planned trip fuel or of the fuel required from the point of in-flight re-planning based on the consumption rate used to plan the trip fuel but, in any case, shall not be lower than the amount required to fly for five minutes at holding speed at 450 m (1 500 ft) above the destination aerodrome in standard conditions;

Note.— Unforeseen factors are those which could have an influence on the fuel consumption to the destination aerodrome, such as deviations of an individual aeroplane from the expected fuel consumption data, deviations from forecast meteorological conditions, extended taxi times before take-off, and deviations from planned routings and/or cruising levels.

- d) *destination alternate fuel*, which shall be:
 - 1) where a destination alternate aerodrome is required, the amount of fuel required to enable the aeroplane to:
 - i) perform a missed approach at the destination aerodrome;
 - ii) climb to the expected cruising altitude;
 - iii) fly the expected routing;
 - iv) descend to the point where the expected approach is initiated; and
 - v) conduct the approach and landing at the destination alternate aerodrome; or
 - 2) where two destination alternate aerodromes are required, the amount of fuel, as calculated in 4.3.6.3 d) 1), required to enable the aeroplane to proceed to the destination alternate aerodrome which requires the greater amount of alternate fuel; or
 - 3) where a flight is operated without a destination alternate aerodrome, the amount of fuel required to enable the aeroplane to fly for 15 minutes at holding speed at 450 m (1 500 ft) above destination aerodrome elevation in standard conditions; or
 - 4) where the aerodrome of intended landing is an isolated aerodrome:

- i) for a reciprocating engine aeroplane, the amount of fuel required to fly for 45 minutes plus 15 per cent of the flight time planned to be spent at cruising level, including final reserve fuel, or two hours, whichever is less; or
 - ii) for a turbine-engined aeroplane, the amount of fuel required to fly for two hours at normal cruise consumption above the destination aerodrome, including final reserve fuel;
- e) *final reserve fuel*, which shall be the amount of fuel calculated using the estimated mass on arrival at the destination alternate aerodrome, or the destination aerodrome when no destination alternate aerodrome is required:
- 1) for a reciprocating engine aeroplane, the amount of fuel required to fly for 45 minutes, under speed and altitude conditions specified by the State of the Operator; or
 - 2) for a turbine-engined aeroplane, the amount of fuel required to fly for 30 minutes at holding speed at 450 m (1 500 ft) above aerodrome elevation in standard conditions;
- f) *additional fuel*, which shall be the supplementary amount of fuel required if the minimum fuel calculated in accordance with 4.3.6.3 b), c), d) and e) is not sufficient to:
- 1) allow the aeroplane to descend as necessary and proceed to an alternate aerodrome in the event of engine failure or loss of pressurization, whichever requires the greater amount of fuel based on the assumption that such a failure occurs at the most critical point along the route;
 - i) fly for 15 minutes at holding speed at 450 m (1 500 ft) above aerodrome elevation in standard conditions; and
 - ii) make an approach and landing;
 - 2) allow an aeroplane engaged in EDTO to comply with the EDTO critical fuel scenario as established by the State of the Operator;
 - 3) meet additional requirements not covered above;

Note 1.— Fuel planning for a failure that occurs at the most critical point along a route (4.3.6.3 f) 1)) may place the aeroplane in a fuel emergency situation based on 4.3.7.2.

Note 2.— Guidance on EDTO critical fuel scenarios is contained in Attachment D;

- g) *discretionary fuel*, which shall be the extra amount of fuel to be carried at the discretion of the pilot-in-command.

4.3.6.4 **Recommendation.**— *Operators should determine one final reserve fuel value for each aeroplane type and variant in their fleet rounded up to an easily recalled figure.*

4.3.6.5 A flight shall not commence unless the usable fuel on board meets the requirements in 4.3.6.3 a), b), c), d), e) and f) if required and shall not continue from the point of in-flight re-planning unless the usable fuel on board meets the requirements in 4.3.6.3 b), c), d), e) and f) if required.

4.3.6.6 Notwithstanding the provisions in 4.3.6.3 a), b), c), d) and f), the State of the Operator may, based on the results of a specific safety risk assessment conducted by the operator which demonstrates how an equivalent level of safety will be maintained, approve variations to the pre-flight fuel calculation of taxi fuel, trip fuel, contingency fuel, destination alternate fuel, and additional fuel. The specific safety risk assessment shall include at least the:

- a) flight fuel calculations;
- b) capabilities of the operator to include:

- i) a data-driven method that includes a fuel consumption monitoring programme; and/or
- ii) the advanced use of alternate aerodromes; and
- c) specific mitigation measures.

Note.— *Guidance on the specific safety risk assessment, fuel consumption monitoring programmes and the advanced use of alternate aerodromes is contained in the Flight Planning and Fuel Management Manual (Doc 9976).*

4.3.7 In-flight fuel management

4.3.7.1 An operator shall establish policies and procedures, approved by the State of the Operator, to ensure that in-flight fuel checks and fuel management are performed.

4.3.7.2 The pilot-in-command shall continually ensure that the amount of usable fuel remaining on board is not less than the fuel required to proceed to an aerodrome where a safe landing can be made with the planned final reserve fuel remaining upon landing.

4.3.7.2.1 The pilot-in-command shall request delay information from ATC when unanticipated circumstances may result in landing at the destination aerodrome with less than the final reserve fuel plus any fuel required to proceed to an alternate aerodrome or the fuel required to operate to an isolated aerodrome.

4.3.7.2.2 The pilot-in-command shall advise ATC of a minimum fuel state by declaring MINIMUM FUEL when, having committed to land at a specific aerodrome, the pilot calculates that any change to the existing clearance to that aerodrome may result in landing with less than the planned final reserve fuel.

Note 1.— *The declaration of MINIMUM FUEL informs ATC that all planned aerodrome options have been reduced to a specific aerodrome of intended landing and any change to the existing clearance may result in landing with less than the planned final reserve fuel. This is not an emergency situation but an indication that an emergency situation is possible should any additional delay occur.*

Note 2.— *Guidance on declaring minimum fuel is contained in the Flight Planning and Fuel Management Manual (Doc 9976).*

4.3.7.2.3 The pilot-in-command shall declare a situation of fuel emergency by broadcasting MAYDAY MAYDAY MAYDAY FUEL, when the calculated usable fuel predicted to be available upon landing at the nearest aerodrome where a safe landing can be made is less than the planned final reserve fuel.

Note 1.— *The planned final reserve fuel refers to the value calculated in 4.3.6.3 e) 1) or 2) and is the minimum amount of fuel required upon landing at any aerodrome.*

Note 2.— *The words “MAYDAY FUEL” describe the nature of the distress conditions as required in Annex 10, Volume II, 5.3.2.1.1 b) 3.*

Note 3.— *Guidance on procedures for in-flight fuel management is contained in the Flight Planning and Fuel Management Manual (Doc 9976).*

4.3.8 Refuelling with passengers on board

4.3.8.1 An aeroplane shall not be refuelled when passengers are embarking, on board or disembarking unless it is properly attended by qualified personnel ready to initiate and direct an evacuation of the aeroplane by the most practical and expeditious means available.

4.3.8.2 When refuelling with passengers embarking, on board or disembarking, two-way communication shall be maintained by the aeroplane's inter-communication system or other suitable means between the ground crew supervising the refuelling and the qualified personnel on board the aeroplane.

Note 1.— The provisions of 4.3.8.1 do not necessarily require the deployment of integral aeroplane stairs or the opening of emergency exits as a prerequisite to refuelling.

Note 2.— Provisions concerning aircraft refuelling are contained in Annex 14, Volume I, and guidance on safe refuelling practices is contained in the Airport Services Manual, (Doc 9137), Parts 1 and 8.

Note 3.— Additional precautions are required when refuelling with fuels other than aviation kerosene or when refuelling results in a mixture of aviation kerosene with other aviation turbine fuels, or when an open line is used.

4.3.9 Oxygen supply

Note.— Approximate altitudes in the Standard Atmosphere corresponding to the values of absolute pressure used in the text are as follows:

Absolute pressure	Metres	Feet
700 hPa	3 000	10 000
620 hPa	4 000	13 000
376 hPa	7 600	25 000

4.3.9.1 A flight to be operated at flight altitudes at which the atmospheric pressure in personnel compartments will be less than 700 hPa shall not be commenced unless sufficient stored breathing oxygen is carried to supply:

- a) all crew members and 10 per cent of the passengers for any period in excess of 30 minutes that the pressure in compartments occupied by them will be between 700 hPa and 620 hPa; and
- b) the crew and passengers for any period that the atmospheric pressure in compartments occupied by them will be less than 620 hPa.

4.3.9.2 A flight to be operated with a pressurized aeroplane shall not be commenced unless a sufficient quantity of stored breathing oxygen is carried to supply all the crew members and passengers, as is appropriate to the circumstances of the flight being undertaken, in the event of loss of pressurization, for any period that the atmospheric pressure in any compartment occupied by them would be less than 700 hPa. In addition, when an aeroplane is operated at flight altitudes at which the atmospheric pressure is less than 376 hPa, or which, if operated at flight altitudes at which the atmospheric pressure is more than 376 hPa and cannot descend safely within four minutes to a flight altitude at which the atmospheric pressure is equal to 620 hPa, there shall be no less than a 10-minute supply for the occupants of the passenger compartment.

4.4 In-flight procedures

4.4.1 Aerodrome operating minima

4.4.1.1 A flight shall not be continued towards the aerodrome of intended landing, unless the latest available information indicates that at the expected time of arrival, a landing can be effected at that aerodrome or at least one destination alternate aerodrome, in compliance with the operating minima established in accordance with 4.2.8.1.

4.4.1.2 An instrument approach shall not be continued beyond the outer marker fix in case of precision approach, or below 300 m (1 000 ft) above the aerodrome in case of non-precision approach, unless the reported visibility or controlling RVR is above the specified minimum.

4.4.1.3 If, after passing the outer marker fix in case of precision approach, or after descending below 300 m (1 000 ft) above the aerodrome in case of non-precision approach, the reported visibility or controlling RVR falls below the specified minimum, the approach may be continued to DA/H or MDA/H. In any case, an aeroplane shall not continue its approach-to-land at any aerodrome beyond a point at which the limits of the operating minima specified for that aerodrome would be infringed.

Note.— Controlling RVR means the reported values of one or more RVR reporting locations (touchdown, mid-point and stop-end) used to determine whether operating minima are or are not met. Where RVR is used, the controlling RVR is the touchdown RVR, unless otherwise specified by State criteria.

4.4.2 Meteorological observations

Note.— The procedures for making meteorological observations on board aircraft in flight and for recording and reporting them are contained in Annex 3, the PANS-ATM (Doc 4444) and the appropriate Regional Supplementary Procedures (Doc 7030).

4.4.3 Hazardous flight conditions

Hazardous flight conditions encountered, other than those associated with meteorological conditions, shall be reported to the appropriate aeronautical station as soon as possible. The reports so rendered shall give such details as may be pertinent to the safety of other aircraft.

4.4.4 Flight crew members at duty stations

4.4.4.1 *Take-off and landing.* All flight crew members required to be on flight deck duty shall be at their stations.

4.4.4.2 *En route.* All flight crew members required to be on flight deck duty shall remain at their stations except when their absence is necessary for the performance of duties in connection with the operation of the aeroplane or for physiological needs.

4.4.4.3 *Seat belts.* All flight crew members shall keep their seat belts fastened when at their stations.

4.4.4.4 *Safety harness.* Any flight crew member occupying a pilot's seat shall keep the safety harness fastened during the take-off and landing phases; all other flight crew members shall keep their safety harnesses fastened during the take-off and landing phases unless the shoulder straps interfere with the performance of their duties, in which case the shoulder straps may be unfastened but the seat belt must remain fastened.

Note.— Safety harness includes shoulder straps and a seat belt which may be used independently.

4.4.5 Use of oxygen

4.4.5.1 All flight crew members, when engaged in performing duties essential to the safe operation of an aeroplane in flight, shall use breathing oxygen continuously whenever the circumstances prevail for which its supply has been required in 4.3.9.1 or 4.3.9.2.

4.4.5.2 All flight crew members of pressurized aeroplanes operating above an altitude where the atmospheric pressure is less than 376 hPa shall have available at the flight duty station a quick-donning type of oxygen mask which will readily supply oxygen upon demand.

4.4.6 Safeguarding of cabin crew and passengers in pressurized aeroplanes in the event of loss of pressurization

Recommendation.— *Cabin crew should be safeguarded so as to ensure reasonable probability of their retaining consciousness during any emergency descent which may be necessary in the event of loss of pressurization and, in addition, they should have such means of protection as will enable them to administer first aid to passengers during stabilized flight following the emergency. Passengers should be safeguarded by such devices or operational procedures as will ensure reasonable probability of their surviving the effects of hypoxia in the event of loss of pressurization.*

Note.— *It is not envisaged that cabin crew will always be able to provide assistance to passengers during emergency descent procedures which may be required in the event of loss of pressurization.*

4.4.7 In-flight operational instructions

Operational instructions involving a change in the ATS flight plan shall, when practicable, be coordinated with the appropriate ATS unit before transmission to the aeroplane.

Note.— *When the above coordination has not been possible, operational instructions do not relieve a pilot of the responsibility for obtaining an appropriate clearance from an ATS unit, if applicable, before making a change in flight plan.*

4.4.8 Instrument flight procedures

4.4.8.1 One or more instrument approach procedures designed in accordance with the classification of instrument approach and landing operations shall be approved and promulgated by the State in which the aerodrome is located to serve each instrument runway or aerodrome utilized for instrument flight operations.

4.4.8.2 All aeroplanes operated in accordance with instrument flight rules shall comply with the instrument flight procedures approved by the State in which the aerodrome is located.

Note 1.— *Definitions for the classification of instrument approach and landing operations are in Chapter 1.*

Note 2.— *Operational procedures recommended for the guidance of operations personnel involved in instrument flight operations are described in PANS-OPS (Doc 8168), Volume I.*

Note 3.— *Criteria for the construction of instrument flight procedures for the guidance of procedure specialists are provided in PANS-OPS (Doc 8168), Volume II.*

4.4.9 Aeroplane operating procedures for noise abatement

4.4.9.1 **Recommendation.**— *Aeroplane operating procedures for noise abatement should comply with the provisions of PANS-OPS (Doc 8168), Volume I.*

4.4.9.2 **Recommendation.**— *Noise abatement procedures specified by an operator for any one aeroplane type should be the same for all aerodromes.*

4.4.10 Aeroplane operating procedures for rates of climb and descent

Recommendation.— *Unless otherwise specified in an air traffic control instruction, to avoid unnecessary airborne collision avoidance system (ACAS II) resolution advisories in aircraft at or approaching adjacent altitudes or flight levels, operators should specify procedures by which an aeroplane climbing or descending to an assigned altitude or flight level, especially with an autopilot engaged, may do so at a rate less than 8 m/sec or 1 500 ft/min (depending on the instrumentation available) throughout the last 300 m (1 000 ft) of climb or descent to the assigned level when the pilot is made aware of another aircraft at or approaching an adjacent altitude or flight level.*

Note.— *Material concerning the development of these procedures is contained in the PANS-OPS (Doc 8168) Volume I, Part III, Section 3, Chapter 3.*

4.5 Duties of pilot-in-command

4.5.1 The pilot-in-command shall be responsible for the safety of all crew members, passengers and cargo on board when the doors are closed. The pilot-in-command shall also be responsible for the operation and safety of the aeroplane from the moment the aeroplane is ready to move for the purpose of taking off until the moment it finally comes to rest at the end of the flight and the engine(s) used as primary propulsion units are shut down.

4.5.2 The pilot-in-command shall ensure that the checklists specified in 4.2.6 are complied with in detail.

4.5.3 The pilot-in-command shall be responsible for notifying the nearest appropriate authority by the quickest available means of any accident involving the aeroplane, resulting in serious injury or death of any person or substantial damage to the aeroplane or property.

Note.— *A definition of the term “serious injury” is contained in Annex 13.*

4.5.4 The pilot-in-command shall be responsible for reporting all known or suspected defects in the aeroplane, to the operator, at the termination of the flight.

4.5.5 The pilot-in-command shall be responsible for the journey log book or the general declaration containing the information listed in 11.4.1.

Note.— *By virtue of Resolution A10-36 of the Tenth Session of the Assembly (Caracas, June–July 1956) “the General Declaration, [described in Annex 9] when prepared so as to contain all the information required by Article 34 [of the Convention on International Civil Aviation] with respect to the journey log book, may be considered by Contracting States to be an acceptable form of journey log book”.*

4.6 Duties of flight operations officer/flight dispatcher

4.6.1 A flight operations officer/flight dispatcher in conjunction with a method of control and supervision of flight operations in accordance with 4.2.1.3 shall:

- a) assist the pilot-in-command in flight preparation and provide the relevant information;
- b) assist the pilot-in-command in preparing the operational and ATS flight plans, sign when applicable and file the ATS flight plan with the appropriate ATS unit; and
- c) furnish the pilot-in-command while in flight, by appropriate means, with information which may be necessary for the safe conduct of the flight.

4.6.2 In the event of an emergency, a flight operations officer/flight dispatcher shall:

- a) initiate such procedures as outlined in the operations manual while avoiding taking any action that would conflict with ATC procedures; and
- b) convey safety-related information to the pilot-in-command that may be necessary for the safe conduct of the flight, including information related to any amendments to the flight plan that become necessary in the course of the flight.

Note.— It is equally important that the pilot-in-command also convey similar information to the flight operations officer/flight dispatcher during the course of the flight, particularly in the context of emergency situations.

4.7 Additional requirements for operations by aeroplanes with turbine engines beyond 60 minutes to an en-route alternate aerodrome including extended diversion time operations (EDTO)

4.7.1 Requirements for operations beyond 60 minutes to an en-route alternate aerodrome

4.7.1.1 Operators conducting operations beyond 60 minutes from a point on a route to an en-route alternate aerodrome shall ensure that:

- a) for all aeroplanes:
 - 1) en-route alternate aerodromes are identified; and
 - 2) the most up-to-date information is provided to the flight crew on identified en-route alternate aerodromes, including operational status and meteorological conditions;
- b) for aeroplanes with two turbine engines, the most up-to-date information provided to the flight crew indicates that conditions at identified en-route alternate aerodromes will be at or above the operator's established aerodrome operating minima for the operation at the estimated time of use.

Note.— Guidance on compliance with the requirements of these provisions is contained in Attachment D.

4.7.1.2 In addition to the requirements in 4.7.1.1, all operators shall ensure that the following are taken into account and provide the overall level of safety intended by the provisions of Annex 6, Part I:

- a) operational control and flight dispatch procedures;
- b) operating procedures; and
- c) training programmes.

4.7.2 Requirements for extended diversion time operations (EDTO)

4.7.2.1 Unless the operation has been specifically approved by the State of the Operator, an aeroplane with two or more turbine engines shall not be operated on a route where the diversion time to an en-route alternate aerodrome from any point on the route, calculated in ISA and still-air conditions at the one-engine-inoperative cruise speed for aeroplanes with two turbine engines and at the all engines operating cruise speed for aeroplanes with more than two turbine engines, exceeds a threshold time established for such operations by that State.

Note 1.— When the diversion time exceeds the threshold time, the operation is considered to be an extended diversion time operation (EDTO).

Note 2.— Guidance on the establishment of an appropriate threshold time and on approval of extended diversion time operations is contained in Attachment D.

Note 3.— For the purpose of EDTO, the take-off and/or destination aerodromes may be considered en-route alternate aerodromes.

4.7.2.2 The maximum diversion time for an operator of a particular aeroplane type engaged in extended diversion time operations shall be approved by the State of the Operator.

Note.— Guidance on the conditions to be used when converting diversion times to distances is contained in Attachment D.

4.7.2.3 When approving the appropriate maximum diversion time for an operator of a particular aeroplane type engaged in extended diversion time operations, the State of the Operator shall ensure that:

- a) *for all aeroplanes:* the most limiting EDTO significant system time limitation, if any, indicated in the aeroplane flight manual (directly or by reference) and relevant to that particular operation is not exceeded; and
- b) *for aeroplanes with two turbine engines:* the aeroplane is EDTO certified.

Note 1.— EDTO may be referred to as ETOPS in some documents.

Note 2.— Guidance on compliance with the requirements of this provision is contained in Attachment D.

4.7.2.3.1 Notwithstanding the provisions in 4.7.2.3 a), the State of the Operator may, based on the results of a specific safety risk assessment conducted by the operator which demonstrates how an equivalent level of safety will be maintained, approve operations beyond the time limits of the most time-limited system. The specific safety risk assessment shall include at least the:

- a) capabilities of the operator;
- b) overall reliability of the aeroplane;
- c) reliability of each time-limited system;
- d) relevant information from the aeroplane manufacturer; and
- e) specific mitigation measures.

Note.— Guidance on the specific safety risk assessment is contained in Attachment D.

4.7.2.4 For aeroplanes engaged in EDTO, the additional fuel required by 4.3.6.3 f) 2) shall include the fuel necessary to comply with the EDTO critical fuel scenario as established by the State of the Operator.

Note.— Guidance on compliance with the requirements of this provision is in Attachment D.

4.7.2.5 A flight shall not proceed beyond the threshold time in accordance with 4.7.2.1 unless the identified en-route alternate aerodromes have been re-evaluated for availability and the most up-to-date information indicates that, during the estimated time of use, conditions at those aerodromes will be at or above the operator's established aerodrome operating minima for the operation. If any conditions are identified that would preclude a safe approach and landing at that aerodrome during the estimated time of use, an alternative course of action shall be determined.

4.7.2.6 The State of the Operator shall, when approving maximum diversion times for aeroplanes with two turbine engines, ensure that the following are taken into account in providing the overall level of safety intended by the provisions of Annex 8:

- a) reliability of the propulsion system;
- b) airworthiness certification for EDTO of the aeroplane type; and
- c) EDTO maintenance programme.

Note 1.— EDTO may be referred to as ETOPS in some documents.

Note 2.— The Airworthiness Manual (Doc 9760) contains guidance on the level of performance and reliability of aeroplane systems intended by 4.7.2.6, as well as guidance on continuing airworthiness aspects of the requirements of 4.7.2.6.

4.7.2.7 **Recommendation.**— *The State of the Operator of an aeroplane type with two turbine engines which, prior to 25 March 1986, was authorized and operating on a route where the flight time at one-engine-inoperative cruise speed to an en-route alternate aerodrome exceeded the threshold time established for such operations in accordance with 4.7.2.1 should give consideration to permitting such an operation to continue on that route after that date.*

4.8 Carry-on baggage

The operator shall ensure that all baggage carried onto an aeroplane and taken into the passenger cabin is adequately and securely stowed.

4.9 Additional requirements for single pilot operations under the instrument flight rules (IFR) or at night

4.9.1 An aeroplane shall not be operated under the IFR or at night by a single pilot unless approved by the State of the Operator.

4.9.2 An aeroplane shall not be operated under the IFR or at night by a single pilot unless:

- a) the flight manual does not require a flight crew of more than one;
- b) the aeroplane is propeller-driven;
- c) the maximum approved passenger seating configuration is not more than nine;
- d) the maximum certificated take-off mass does not exceed 5 700 kg;
- e) the aeroplane is equipped as described in 6.22; and
- f) the pilot-in-command has satisfied requirements of experience, training, checking and recency described in 9.4.5.

4.10 Fatigue management

4.10.1 The State of the Operator shall establish regulations for the purpose of managing fatigue. These regulations shall be based upon scientific principles and knowledge, with the aim of ensuring that flight and cabin crew members are performing at an adequate level of alertness. Accordingly, the State of the Operator shall establish:

- a) regulations for flight time, flight duty period, duty period and rest period limitations; and
- b) where authorizing an operator to use a Fatigue Risk Management System (FRMS) to manage fatigue, FRMS regulations.

Note.— *Guidance for the development of prescriptive regulations to manage fatigue is given in Attachment A and detailed requirements for an FRMS are in Appendix 8.*

4.10.2 The State of the Operator shall require that the operator, in compliance with 4.10.1 and for the purposes of managing its fatigue-related safety risks, establish either:

- a) flight time, flight duty period, duty period and rest period limitations that are within the prescriptive fatigue management regulations established by the State of the Operator; or
- b) a Fatigue Risk Management System (FRMS) in compliance with 4.10.6 for all operations; or
- c) an FRMS in compliance with 4.10.6 for part of its operations and the requirements of 4.10.2 a) for the remainder of its operations.

Note.— *Guidance for the implementation and oversight of an FRMS is given in the Fatigue Risk Management Systems Manual for Regulators (Doc 9966).*

4.10.3 Where the operator adopts prescriptive fatigue management regulations for part or all of its operations, the State of the Operator may approve, in exceptional circumstances, variations to these regulations on the basis of a risk assessment provided by the operator. Approved variations shall provide a level of safety equivalent to, or better than, that achieved through the prescriptive fatigue management regulations.

4.10.4 The State of the Operator shall approve an operator's FRMS before it may take the place of any or all of the prescriptive fatigue management regulations. An approved FRMS shall provide a level of safety equivalent to, or better than, the prescriptive fatigue management regulations.

4.10.5 States that approve an operator's FRMS shall establish a process to ensure that an FRMS provides a level of safety equivalent to, or better than, the prescriptive fatigue management regulations. As part of this process, the State of the Operator shall:

- a) require that the operator establish maximum values for flight times and/or flight duty periods(s) and duty period(s), and minimum values for rest periods. These values shall be based upon scientific principles and knowledge, subject to safety assurance processes, and acceptable to the State of the Operator;
- b) mandate a decrease in maximum values and an increase in minimum values in the event that the operator's data indicates these values are too high or too low, respectively; and
- c) approve any increase in maximum values or decrease in minimum values only after evaluating the operator's justification for such changes, based on accumulated FRMS experience and fatigue-related data.

Note.— *Safety assurance processes are described in Appendix 8.*

4.10.6 Where an operator implements an FRMS to manage fatigue-related safety risks, the operator shall, as a minimum:

- a) incorporate scientific principles and knowledge within the FRMS;
- b) identify fatigue-related safety hazards and the resulting risks on an ongoing basis;

- c) ensure that remedial actions, necessary to effectively mitigate the risks associated with the hazards, are implemented promptly;
- d) provide for continuous monitoring and regular assessment of the mitigation of fatigue risks achieved by such actions; and
- e) provide for continuous improvement to the overall performance of the FRMS.

Note.— Detailed requirements for an FRMS are in Appendix 8.

4.10.7 **Recommendation.**— States should require that, where an operator has an FRMS, it is integrated with the operator's SMS.

Note.— The integration of FRMS and SMS is described in the Fatigue Risk Management Systems Manual for Regulators (Doc 9966).

4.10.8 An operator shall maintain records for all its flight and cabin crew members of flight time, flight duty periods, duty periods, and rest periods for a period of time specified by the State of the Operator.

CHAPTER 5. AEROPLANE PERFORMANCE OPERATING LIMITATIONS

5.1 General

5.1.1 Aeroplanes shall be operated in accordance with a comprehensive and detailed code of performance established by the State of Registry in compliance with the applicable Standards of this chapter.

5.1.2 Except as provided in 5.4, single-engine aeroplanes shall only be operated in conditions of weather and light, and over such routes and diversions therefrom, that permit a safe forced landing to be executed in the event of engine failure.

5.1.3 **Recommendation.**— *For aeroplanes for which Parts IIIA and IIIB of Annex 8 are not applicable because of the exemption provided for in Article 41 of the Convention, the State of Registry should ensure that the level of performance specified in 5.2 should be met as far as practicable.*

5.2 Applicable to aeroplanes certificated in accordance with Parts IIIA and IIIB of Annex 8

5.2.1 The Standards contained in 5.2.2 to 5.2.11 inclusive are applicable to the large aeroplanes to which Parts IIIA and IIIB of Annex 8 are applicable.

Note.— *The following Standards do not include quantitative specifications comparable to those found in national airworthiness codes. In accordance with 5.1.1, they are to be supplemented by national requirements prepared by Contracting States.*

5.2.2 The level of performance defined by the appropriate parts of the comprehensive and detailed national code referred to in 5.1.1 for the aeroplanes designated in 5.2.1 shall be at least substantially equivalent to the overall level embodied in the Standards of this chapter.

Note.— *Attachment C contains guidance material which indicates the level of performance intended by the Standards and Recommended Practices of this chapter.*

5.2.3 An aeroplane shall be operated in compliance with the terms of its certificate of airworthiness and within the approved operating limitations contained in its flight manual.

5.2.4 The State of Registry shall take such precautions as are reasonably possible to ensure that the general level of safety contemplated by these provisions is maintained under all expected operating conditions, including those not covered specifically by the provisions of this chapter.

5.2.5 A flight shall not be commenced unless the performance information provided in the flight manual, supplemented as necessary with other data acceptable to the State of the Operator, indicates that the Standards of 5.2.6 to 5.2.11 can be complied with for the flight to be undertaken.

5.2.6 In applying the Standards of this chapter, account shall be taken of all factors that significantly affect the performance of the aeroplane, including but not limited to: the mass of the aeroplane, the operating procedures, the pressure-altitude appropriate to the elevation of the aerodrome, the ambient temperature, the wind, the runway slope, and

surface conditions of the runway i.e., presence of snow, slush, water, and/or ice for landplanes, water surface condition for seaplanes. Such factors shall be taken into account directly as operational parameters or indirectly by means of allowances or margins, which may be provided in the scheduling of performance data or in the comprehensive and detailed code of performance in accordance with which the aeroplane is being operated.

5.2.7 Mass limitations

- a) The mass of the aeroplane at the start of take-off shall not exceed the mass at which 5.2.8 is complied with, nor the mass at which 5.2.9, 5.2.10 and 5.2.11 are complied with, allowing for expected reductions in mass as the flight proceeds, and for such fuel jettisoning as is envisaged in applying 5.2.9 and 5.2.10 and, in respect of alternate aerodromes, 5.2.7 c) and 5.2.11.
- b) In no case shall the mass at the start of take-off exceed the maximum take-off mass specified in the flight manual for the pressure-altitude appropriate to the elevation of the aerodrome, and, if used as a parameter to determine the maximum take-off mass, any other local atmospheric condition.
- c) In no case shall the estimated mass for the expected time of landing at the aerodrome of intended landing and at any destination alternate aerodrome, exceed the maximum landing mass specified in the flight manual for the pressure-altitude appropriate to the elevation of those aerodromes, and if used as a parameter to determine the maximum landing mass, any other local atmospheric condition.
- d) In no case shall the mass at the start of take-off, or at the expected time of landing at the aerodrome of intended landing and at any destination alternate aerodrome, exceed the relevant maximum masses at which compliance has been demonstrated with the applicable noise certification Standards in Annex 16, Volume I, unless otherwise authorized in exceptional circumstances for a certain aerodrome or a runway where there is no noise disturbance problem, by the competent authority of the State in which the aerodrome is situated.

5.2.8 *Take-off.* The aeroplane shall be able, in the event of a critical engine failing, or for other reasons, at any point in the take-off, either to discontinue the take-off and stop within the accelerate-stop distance available, or to continue the take-off and clear all obstacles along the flight path by an adequate vertical or horizontal distance until the aeroplane is in a position to comply with 5.2.9. When determining the resulting take-off obstacle accountability area, the operating conditions, such as the crosswind component and navigation accuracy, must be taken into account.

Note.— Attachment C contains guidance on the vertical and horizontal distances that are considered adequate to show compliance with this Standard.

5.2.8.1 In determining the length of the runway available, account shall be taken of the loss, if any, of runway length due to alignment of the aeroplane prior to take-off.

5.2.9 *En route — one engine inoperative.* The aeroplane shall be able, in the event of the critical engine becoming inoperative at any point along the route or planned diversions therefrom, to continue the flight to an aerodrome at which the Standard of 5.2.11 can be met, without flying below the minimum flight altitude at any point.

5.2.10 *En route — two engines inoperative.* In the case of aeroplanes having three or more engines, on any part of a route where the location of en-route alternate aerodromes and the total duration of the flight are such that the probability of a second engine becoming inoperative must be allowed for if the general level of safety implied by the Standards of this chapter is to be maintained, the aeroplane shall be able, in the event of any two engines becoming inoperative, to continue the flight to an en-route alternate aerodrome and land.

5.2.11 *Landing.* The aeroplane shall, at the aerodrome of intended landing and at any alternate aerodrome, after clearing all obstacles in the approach path by a safe margin, be able to land, with assurance that it can come to a stop or, for a seaplane,

to a satisfactorily low speed, within the landing distance available. Allowance shall be made for expected variations in the approach and landing techniques, if such allowance has not been made in the scheduling of performance data.

5.3 Obstacle data

5.3.1 Obstacle data shall be provided to enable the operator to develop procedures to comply with 5.2.8.

Note.— See Annex 4 and Annex 15 for methods of presentation of certain obstacle data.

5.3.2 The operator shall take account of charting accuracy when assessing compliance with 5.2.8.

5.4 Additional requirements for operations of single-engine turbine-powered aeroplanes at night and/or in Instrument Meteorological Conditions (IMC)

5.4.1 In approving operations by single-engine turbine-powered aeroplanes at night and/or in IMC, the State of the Operator shall ensure that the airworthiness certification of the aeroplane is appropriate and that the overall level of safety intended by the provisions of Annexes 6 and 8 is provided by:

- a) the reliability of the turbine engine;
- b) the operator's maintenance procedures, operating practices, flight dispatch procedures and crew training programmes; and
- c) equipment and other requirements provided in accordance with Appendix 3.

5.4.2 All single-engine turbine-powered aeroplanes operated at night and/or in IMC shall have an engine trend monitoring system, and those aeroplanes for which the individual certificate of airworthiness is first issued on or after 1 January 2005 shall have an automatic trend monitoring system.

CHAPTER 6. AEROPLANE INSTRUMENTS, EQUIPMENT AND FLIGHT DOCUMENTS

Note.— Specifications for the provision of aeroplane communication and navigation equipment are contained in Chapter 7.

6.1 General

6.1.1 In addition to the minimum equipment necessary for the issuance of a certificate of airworthiness, the instruments, equipment and flight documents prescribed in the following paragraphs shall be installed or carried, as appropriate, in aeroplanes according to the aeroplane used and to the circumstances under which the flight is to be conducted. The prescribed instruments and equipment, including their installation, shall be approved or accepted by the State of Registry.

6.1.2 An aeroplane shall carry a certified true copy of the air operator certificate specified in 4.2.1, and a copy of the operations specifications relevant to the aeroplane type, issued in conjunction with the certificate. When the certificate and the associated operations specifications are issued by the State of the Operator in a language other than English, an English translation shall be included.

Note.— Provisions for the content of the air operator certificate and its associated operations specifications are contained in 4.2.1.5 and 4.2.1.6.

6.1.3 The operator shall include in the operations manual a minimum equipment list (MEL), approved by the State of the Operator which will enable the pilot-in-command to determine whether a flight may be commenced or continued from any intermediate stop should any instrument, equipment or systems become inoperative. Where the State of the Operator is not the State of Registry, the State of the Operator shall ensure that the MEL does not affect the aeroplane's compliance with the airworthiness requirements applicable in the State of Registry.

Note.— Attachment F contains guidance on the minimum equipment list.

6.1.4 The operator shall provide operations staff and flight crew with an aircraft operating manual, for each aircraft type operated, containing the normal, abnormal and emergency procedures relating to the operation of the aircraft. The manual shall include details of the aircraft systems and of the checklists to be used. The design of the manual shall observe Human Factors principles.

Note.— Guidance material on the application of Human Factors principles can be found in the Human Factors Training Manual (Doc 9683).

6.2 All aeroplanes on all flights

6.2.1 An aeroplane shall be equipped with instruments which will enable the flight crew to control the flight path of the aeroplane, carry out any required procedural manoeuvres and observe the operating limitations of the aeroplane in the expected operating conditions.

6.2.2 An aeroplane shall be equipped with:

- a) accessible and adequate medical supplies;

Recommendation.— *Medical supplies should comprise:*

- 1) *one or more first-aid kits for the use of cabin crew in managing incidents of ill health; and*
- 2) *for aeroplanes required to carry cabin crew as part of the operating crew, one universal precaution kit (two for aeroplanes authorized to carry more than 250 passengers) for the use of cabin crew members in managing incidents of ill health associated with a case of suspected communicable disease, or in the case of illness involving contact with body fluids; and*
- 3) *for aeroplanes authorized to carry more than 100 passengers, on a sector length of more than two hours, a medical kit, for the use of medical doctors or other qualified persons in treating in-flight medical emergencies.*

Note.— *Guidance on the types, number, location and contents of the medical supplies is given in Attachment B.*

- b) portable fire extinguishers of a type which, when discharged, will not cause dangerous contamination of the air within the aeroplane. At least one shall be located in:

- 1) the pilot's compartment; and
- 2) each passenger compartment that is separate from the pilot's compartment and that is not readily accessible to the flight crew;

Note 1.— *Any portable fire extinguisher so fitted in accordance with the certificate of airworthiness of the aeroplane may count as one prescribed.*

Note 2.— *Refer to 6.2.2.1 for fire extinguishing agents.*

- c) 1) a seat or berth for each person over an age to be determined by the State of the Operator;
- 2) a seat belt for each seat and restraining belts for each berth; and
- 3) a safety harness for each flight crew seat. The safety harness for each pilot seat shall incorporate a device which will automatically restrain the occupant's torso in the event of rapid deceleration;

Recommendation.— *The safety harness for each pilot seat should incorporate a device to prevent a suddenly incapacitated pilot from interfering with the flight controls.*

Note.— *Safety harness includes shoulder straps and a seat belt which may be used independently.*

- d) means of ensuring that the following information and instructions are conveyed to passengers:

- 1) when seat belts are to be fastened;
- 2) when and how oxygen equipment is to be used if the carriage of oxygen is required;
- 3) restrictions on smoking;
- 4) location and use of life jackets or equivalent individual flotation devices where their carriage is required; and
- 5) location and method of opening emergency exits; and

- e) spare electrical fuses of appropriate ratings for replacement of those accessible in flight.

6.2.2.1 Any agent used in a built-in fire extinguisher for each lavatory disposal receptacle for towels, paper or waste in an aeroplane for which the individual certificate of airworthiness is first issued on or after 31 December 2011 and any extinguishing agent used in a portable fire extinguisher in an aeroplane for which the individual certificate of airworthiness is first issued on or after 31 December 2016 shall:

- a) meet the applicable minimum performance requirements of the State of Registry; and
- b) not be of a type listed in the 1987 *Montreal Protocol on Substances that Deplete the Ozone Layer* as it appears in the Eighth Edition of the *Handbook for the Montreal Protocol on Substances that Deplete the Ozone Layer*, Annex A, Group II.

Note.— Information concerning extinguishing agents is contained in the UNEP Halons Technical Options Committee Technical Note No. 1 – New Technology Halon Alternatives and FAA Report No. DOT/FAA/AR-99-63, Options to the Use of Halons for Aircraft Fire Suppression Systems.

6.2.3 An aeroplane shall carry:

- a) the operations manual prescribed in 4.2.3, or those parts of it that pertain to flight operations;
- b) the flight manual for the aeroplane, or other documents containing performance data required for the application of Chapter 5 and any other information necessary for the operation of the aeroplane within the terms of its certificate of airworthiness, unless these data are available in the operations manual; and
- c) current and suitable charts to cover the route of the proposed flight and any route along which it is reasonable to expect that the flight may be diverted.

6.2.4 Marking of break-in points

6.2.4.1 If areas of the fuselage suitable for break-in by rescue crews in an emergency are marked on an aeroplane, such areas shall be marked as shown below (see figure following). The colour of the markings shall be red or yellow, and if necessary they shall be outlined in white to contrast with the background.

6.2.4.2 If the corner markings are more than 2 m apart, intermediate lines 9 cm × 3 cm shall be inserted so that there is no more than 2 m between adjacent markings.

Note.— This Standard does not require any aeroplane to have break-in areas.

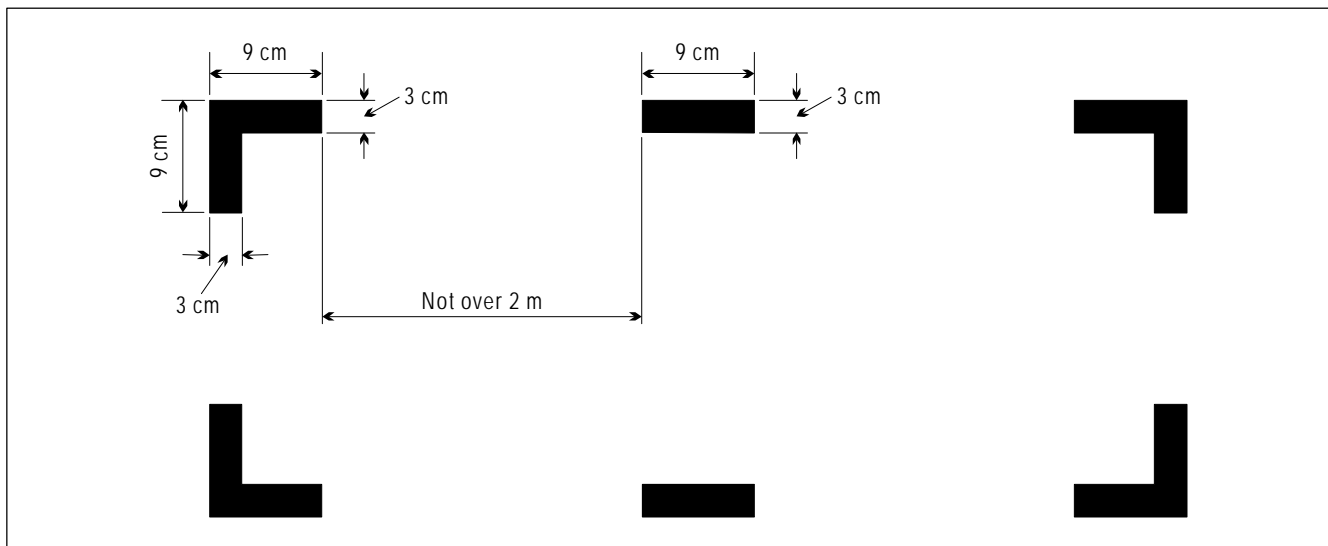

MARKING OF BREAK-IN POINTS (see 6.2.4)

6.3 Flight recorders

Note 1.— Crash protected flight recorders comprise one or more of the following systems: a flight data recorder (FDR), a cockpit voice recorder (CVR), an airborne image recorder (AIR) and/or a data link recorder (DLR). Image and data link information may be recorded on either the CVR or the FDR.

Note 2.— Lightweight flight recorders comprise one or more of the following systems: an aircraft data recording system (ADRS), a cockpit audio recording system (CARS), an airborne image recording system (AIRS) and/or a data link recording system (DLRS). Image and data link information may be recorded on either the CARS or the ADRS.

Note 3.— Detailed guidance on flight recorders is contained in Appendix 9.

6.3.1 Flight data recorders and aircraft data recording systems

Note 1.— FDR and AIR performance requirements are as contained in the EUROCAE ED-112, Minimum Operational Performance Specification (MOPS) for Crash Protected Airborne Recorder Systems, or equivalent documents.

Note 2.— ADRS performance requirements are as contained in the EUROCAE ED-155, Minimum Operational Performance Specification (MOPS) for Lightweight Flight Recording Systems, or equivalent documents.

Note 3.—Parameters to be recorded are listed in Tables A9-1 and A9-3 of Appendix 9.

6.3.1.1 Types

6.3.1.1.1 Types I and IA FDR shall record the parameters required to determine accurately the aeroplane flight path, speed, attitude, engine power, configuration and operation.

6.3.1.1.2 Types II and IIA FDRs shall record the parameters required to determine accurately the aeroplane flight path, speed, attitude, engine power and configuration of lift and drag devices.

6.3.1.2 Operation

Note.— Airborne image recorders (AIRs) classification is defined in 4.1 of Appendix 9.

6.3.1.2.1 All turbine-engined aeroplanes of a maximum certificated take-off mass of 5 700 kg or less for which the application for type certification is submitted to a Contracting State on or after 1 January 2016 shall be equipped with:

- a) a Type II FDR; or
- b) a Class C AIR capable of recording flight path and speed parameters displayed to the pilot(s); or
- c) an ADRS capable of recording the essential parameters defined in Table A9-3 of Appendix 9.

Note.— “The application for type certification is submitted to a Contracting State” refers to the date of application of the original “Type Certificate” for the aeroplane type, not the date of certification of particular aeroplane variants or derivative models.

6.3.1.2.2 **Recommendation.**— All turbine-engined aeroplanes of a maximum certificated take-off mass of 5 700 kg or less for which the individual certificate of airworthiness is first issued on or after 1 January 2016 should be equipped with:

- a) a Type II FDR; or
- b) a Class C AIR capable of recording flight path and speed parameters displayed to the pilot(s); or
- c) an ADRS capable of recording the essential parameters defined in Table A9-3 of Appendix 9.

6.3.1.2.3 All aeroplanes of a maximum certificated take-off mass of over 27 000 kg for which the individual certificate of airworthiness is first issued on or after 1 January 1989 shall be equipped with a Type I FDR.

6.3.1.2.4 All aeroplanes of a maximum certificated take-off mass of over 5 700 kg, up to and including 27 000 kg, for which the individual certificate of airworthiness is first issued on or after 1 January 1989, shall be equipped with a Type II FDR.

6.3.1.2.5 **Recommendation.**— *All multi-engined turbine-engined aeroplanes of a maximum certificated take-off mass of 5 700 kg or less for which the individual certificate of airworthiness is first issued on or after 1 January 1990 should be equipped with a Type IIA FDR.*

6.3.1.2.6 All turbine-engined aeroplanes, for which the individual certificate of airworthiness was first issued on or after 1 January 1987 but before 1 January 1989, with a maximum certificated take-off mass of over 5 700 kg, except those in 6.3.1.2.8, shall be equipped with an FDR which shall record time, altitude, airspeed, normal acceleration and heading.

6.3.1.2.7 **Recommendation.**— *All turbine-engined aeroplanes, for which the individual certificate of airworthiness was first issued on or after 1 January 1987 but before 1 January 1989, with a maximum certificated take-off mass of over 5 700 kg, except those in 6.3.1.2.8, should be equipped with an FDR which shall record time, altitude, airspeed, normal acceleration, heading and such additional parameters as are necessary to determine pitch attitude, roll attitude, radio transmission keying and power on each engine.*

6.3.1.2.8 All turbine-engined aeroplanes, for which the individual certificate of airworthiness was first issued on or after 1 January 1987 but before 1 January 1989, with a maximum certificated take-off mass of over 27 000 kg that are of types of which the prototype was certificated by the appropriate national authority after 30 September 1969 shall be equipped with a Type II FDR.

6.3.1.2.9 All turbine-engined aeroplanes, for which the individual certificate of airworthiness was first issued before 1 January 1987, with a maximum certificated take-off mass of over 5 700 kg shall be equipped with an FDR which shall record time, altitude, airspeed, normal acceleration and heading.

6.3.1.2.10 **Recommendation.**— *All turbine-engined aeroplanes, for which the individual certificate of airworthiness was first issued before 1 January 1987, with a maximum certificated take-off mass of over 27 000 kg that are of types of which the prototype was certificated by the appropriate national authority after 30 September 1969 should be equipped with an FDR which should record, in addition to time, altitude, airspeed, normal acceleration and heading, such additional parameters as are necessary to meet the objectives of determining:*

- a) *the attitude of the aeroplane in achieving its flight path; and*
- b) *the basic forces acting upon the aeroplane resulting in the achieved flight path and the origin of such basic forces.*

6.3.1.2.11 All aeroplanes of a maximum certificated take-off mass of over 5 700 kg for which the individual certificate of airworthiness is first issued after 1 January 2005 shall be equipped with a Type IA FDR.

6.3.1.2.12 All aeroplanes which are required to record normal acceleration, lateral acceleration and longitudinal acceleration for which the application for type certification is submitted to a Contracting State on or after 1 January 2016 and which are required to be fitted with an FDR shall record those parameters at a maximum sampling and recording interval of 0.0625 seconds.

6.3.1.2.13 All aeroplanes which are required to record pilot input and/or control surface position of primary controls (pitch, roll, yaw) for which the application for type certification is submitted to a Contracting State on or after 1 January 2016 and which are required to be fitted with an FDR shall record those parameters at a maximum sampling and recording interval of 0.125 seconds.

Note.— For aeroplanes with control systems in which movement of a control surface will back drive the pilot's control, "or" applies. For aeroplanes with control systems in which movement of a control surface will not back drive the pilot's control, "and" applies. In aeroplanes with independent moveable surfaces, each surface needs to be recorded separately. In aeroplanes with independent pilot input on primary controls, each pilot input on primary controls needs to be recorded separately.

6.3.1.3 Discontinuation

6.3.1.3.1 The use of engraving metal foil FDRs shall be discontinued.

6.3.1.3.2 **Recommendation.**— *The use of analogue FDRs using frequency modulation (FM) should be discontinued.*

6.3.1.3.3 The use of analogue FDRs using frequency modulation (FM) shall be discontinued by 1 January 2012.

6.3.1.3.4 The use of photographic film FDRs shall be discontinued.

6.3.1.3.5 **Recommendation.**— *The use of magnetic tape FDRs should be discontinued by 1 January 2011.*

6.3.1.3.6 The use of magnetic tape FDRs shall be discontinued by 1 January 2016.

6.3.1.4 Duration

All FDRs shall be capable of retaining the information recorded during at least the last 25 hours of their operation, except for the Type IIA FDR which shall be capable of retaining the information recorded during at least the last 30 minutes of its operation.

6.3.2 Cockpit voice recorders and cockpit audio recording systems

Note 1.— CVR performance requirements are as contained in the EUROCAE ED-112, Minimum Operational Performance Specification (MOPS) for Crash Protected Airborne Recorder Systems, or equivalent documents.

Note 2.— CARS performance requirements are as contained in the EUROCAE ED-155, Minimum Operational Performance Specification (MOPS) for Lightweight Flight Recording Systems, or equivalent documents.

6.3.2.1 Operation

6.3.2.1.1 All turbine-engined aeroplanes of a maximum certificated take-off mass of over 2 250 kg, up to and including 5 700 kg, for which the application for type certification is submitted to a Contracting State on or after 1 January 2016 and required to be operated by more than one pilot shall be equipped with either a CVR or a CARS.

6.3.2.1.2 **Recommendation.**— *All turbine-engined aeroplanes of a maximum certificated take-off mass of 5 700 kg or less for which the individual certificate of airworthiness is first issued on or after 1 January 2016 and required to be operated by more than one pilot should be equipped with either a CVR or a CARS.*

6.3.2.1.3 All aeroplanes of a maximum certificated take-off mass of over 5 700 kg for which the individual certificate of airworthiness is first issued on or after 1 January 2003 shall be equipped with a CVR capable of retaining the information recorded during at least the last two hours of its operation.

6.3.2.1.4 All aeroplanes of a maximum certificated take-off mass of over 5 700 kg for which the individual certificate of airworthiness is first issued on or after 1 January 1987 shall be equipped with a CVR.

6.3.2.1.5 All turbine-engined aeroplanes, for which the individual certificate of airworthiness was first issued before 1 January 1987, with a maximum certificated take-off mass of over 27 000 kg that are of types of which the prototype was certificated by the appropriate national authority after 30 September 1969 shall be equipped with a CVR.

6.3.2.1.6 **Recommendation.**— *All turbine-engined aeroplanes, for which the individual certificate of airworthiness was first issued before 1 January 1987, with a maximum certificated take-off mass of over 5 700 kg up to and including 27 000 kg that are of types of which the prototype was certificated by the appropriate national authority after 30 September 1969 should be equipped with a CVR.*

6.3.2.2 Discontinuation

6.3.2.2.1 The use of magnetic tape and wire CVRs shall be discontinued by 1 January 2016.

6.3.2.2.2 **Recommendation.**— *The use of magnetic tape and wire CVRs should be discontinued by 1 January 2011.*

6.3.2.3 Duration

6.3.2.3.1 All CVRs shall be capable of retaining the information recorded during at least the last 30 minutes of their operation.

6.3.2.3.2 From 1 January 2016, all CVRs shall be capable of retaining the information recorded during at least the last two hours of their operation.

6.3.2.3.3 **Recommendation.**— *All aeroplanes, for which the individual certificate of airworthiness is first issued on or after 1 January 1990, and that are required to be equipped with a CVR, should have a CVR capable of retaining the information recorded during at least the last two hours of their operation.*

6.3.2.4 Cockpit voice recorder alternate power

6.3.2.4.1 An alternate power source shall automatically engage and provide ten minutes, plus or minus one minute, of operation whenever aeroplane power to the recorder ceases, either by normal shutdown or by any other loss of power. The alternate power source shall power the CVR and its associated cockpit area microphone components. The CVR shall be located as close as practicable to the alternate power source.

Note 1.— “Alternate” means separate from the power source that normally provides power to the CVR. The use of aeroplane batteries or other power sources is acceptable provided that the requirements above are met and electrical power to essential and critical loads is not compromised.

Note 2.— When the CVR function is combined with other recording functions within the same unit, powering the other functions is allowed.

6.3.2.4.2 All aeroplanes of a maximum certificated take-off mass of over 27 000 kg for which the application for type certification is submitted to a Contracting State on or after 1 January 2018 shall be provided with an alternate power source, as defined in 6.3.2.4.1, that powers the forward CVR in the case of combination recorders.

6.3.2.4.3 **Recommendation.**— *All aeroplanes of a maximum certificated take-off mass of over 27 000 kg for which the individual certificate of airworthiness is first issued on or after 1 January 2018 should be provided with an alternate power source, as defined in 6.3.2.4.1, that powers at least one CVR.*

6.3.3 Data link recorders

Note.— *Data link recorders performance requirements are as contained in the EUROCAE ED-112, Minimum Operational Performance Specifications (MOPS) for Crash Protected Airborne Recorder Systems, or equivalent documents.*

6.3.3.1 Applicability

6.3.3.1.1 All aeroplanes for which the individual certificate of airworthiness is first issued on or after 1 January 2016, which utilize any of the data link communications applications listed in 5.1.2 of Appendix 9 and are required to carry a CVR, shall record on a flight recorder the data link communications messages.

6.3.3.1.2 All aeroplanes which are modified on or after 1 January 2016 to install and utilize any of the data link communications applications listed in 5.1.2 of Appendix 9 and are required to carry a CVR shall record on a flight recorder the data link communications messages.

Note 1.— *Data link communications are currently conducted by either ATN-based or FANS I/A-equipped aircraft.*

Note 2.— *A Class B AIR could be a means for recording data link communications applications messages to and from the aeroplanes where it is not practical or is prohibitively expensive to record those data link communications applications messages on FDR or CVR.*

6.3.3.2 Duration

The minimum recording duration shall be equal to the duration of the CVR.

6.3.3.3 Correlation

Data link recording shall be able to be correlated to the recorded cockpit audio.

6.3.4 Flight recorders — general

6.3.4.1 Construction and installation

Flight recorders shall be constructed, located and installed so as to provide maximum practical protection for the recordings in order that the recorded information may be preserved, recovered and transcribed. Flight recorders shall meet the prescribed crashworthiness and fire protection specifications.

Note 1.— *Industry crashworthiness and fire protection specifications for FDR, CVR, AIR and DLR are as contained in the EUROCAE ED-112, Minimum Operational Performance Specifications (MOPS) for Crash Protected Airborne Recorder Systems, or equivalent documents.*

Note 2.— *Industry crashworthiness and fire protection specifications for ADRS and CARS are as contained in the EUROCAE ED-155, Minimum Operational Performance Specifications (MOPS) for Lightweight Flight Recording Systems, or equivalent documents.*

6.3.4.2 Operation

6.3.4.2.1 Flight recorders shall not be switched off during flight time.

6.3.4.2.2 To preserve flight recorder records, flight recorders shall be deactivated upon completion of flight time following an accident or incident. The flight recorders shall not be reactivated before their disposition as determined in accordance with Annex 13.

Note 1.— The need for removal of the flight recorder records from the aircraft will be determined by the investigation authority in the State conducting the investigation with due regard to the seriousness of an occurrence and the circumstances, including the impact on the operation.

Note 2.— The operator's responsibilities regarding the retention of flight recorder records are contained in 11.6.

6.3.4.3 Continued serviceability

Operational checks and evaluations of recordings from the flight recorder systems shall be conducted to ensure the continued serviceability of the recorders.

Note.— Procedures for the inspections of the flight recorder systems are given in Appendix 9.

6.3.4.4 Flight recorder electronic documentation

Recommendation.— *The documentation requirement concerning FDR and ADRS parameters provided by operators to accident investigation authorities should be in electronic format and take account of industry specifications.*

Note.— Industry specification for documentation concerning flight recorder parameters may be found in the ARINC 647A, Flight Recorder Electronic Documentation, or equivalent document.

6.3.4.5 Combination recorders

6.3.4.5.1 **Recommendation.**— *All aeroplanes of a maximum certificated take-off mass of over 5 700 kg for which the application for type certification is submitted to a Contracting State on or after 1 January 2016, and which are required to be equipped with both a CVR and an FDR, should be equipped with two combination recorders (FDR/CVR).*

6.3.4.5.2 All aeroplanes of a maximum certificated take-off mass of over 15 000 kg for which the application for type certification is submitted to a Contracting State on or after 1 January 2016, and which are required to be equipped with both a CVR and an FDR, shall be equipped with two combination recorders (FDR/CVR). One recorder shall be located as close to the cockpit as practicable and the other recorder located as far aft as practicable.

6.3.4.5.3 **Recommendation.**— *All aeroplanes of a maximum certificated take-off mass over 5 700 kg, required to be equipped with an FDR and a CVR, may alternatively be equipped with two combination recorders (FDR/CVR).*

Note.— The requirement of 6.3.4.5 may be satisfied by equipping the aeroplanes with two combination recorders (one forward and one aft) or separate devices.

6.3.4.5.4 **Recommendation.**— *All multi-engined turbine-powered aeroplanes of a maximum certificated take-off mass of 5 700 kg or less, required to be equipped with an FDR and/or a CVR, may alternatively be equipped with one combination recorder (FDR/CVR).*

6.4 All aeroplanes operated as VFR flights

6.4.1 All aeroplanes when operated as VFR flights shall be equipped with:

- a) a magnetic compass;
- b) an accurate timepiece indicating the time in hours, minutes and seconds;
- c) a sensitive pressure altimeter;
- d) an airspeed indicator; and
- e) such additional instruments or equipment as may be prescribed by the appropriate authority.

6.4.2 VFR flights which are operated as controlled flights shall be equipped in accordance with 6.9.

6.5 All aeroplanes on flights over water

6.5.1 Seaplanes

All seaplanes for all flights shall be equipped with:

- a) one life jacket, or equivalent individual flotation device, for each person on board, stowed in a position easily accessible from the seat or berth of the person for whose use it is provided;
- b) equipment for making the sound signals prescribed in the International Regulations for Preventing Collisions at Sea, where applicable; and
- c) one sea anchor (drogue).

Note.— “Seaplanes” includes amphibians operated as seaplanes.

6.5.2 Landplanes

6.5.2.1 Landplanes shall carry the equipment prescribed in 6.5.2.2:

- a) when flying over water and at a distance of more than 93 km (50 NM) away from the shore, in the case of landplanes operated in accordance with 5.2.9 or 5.2.10;
- b) when flying en route over water beyond gliding distance from the shore, in the case of all other landplanes; and
- c) when taking off or landing at an aerodrome where, in the opinion of the State of the Operator, the take-off or approach path is so disposed over water that in the event of a mishap there would be a likelihood of a ditching.

6.5.2.2 The equipment referred to in 6.5.2.1 shall comprise one life jacket or equivalent individual flotation device for each person on board, stowed in a position easily accessible from the seat or berth of the person for whose use it is provided.

Note.— “Landplanes” includes amphibians operated as landplanes.

6.5.3 All aeroplanes on long-range over-water flights

6.5.3.1 In addition to the equipment prescribed in 6.5.1 or 6.5.2 whichever is applicable, the following equipment shall be installed in all aeroplanes when used over routes on which the aeroplane may be over water and at more than a distance corresponding to 120 minutes at cruising speed or 740 km (400 NM), whichever is the lesser, away from land suitable for making an emergency landing in the case of aircraft operated in accordance with 5.2.9 or 5.2.10, and 30 minutes or 185 km (100 NM), whichever is the lesser, for all other aeroplanes:

- a) life-saving rafts in sufficient numbers to carry all persons on board, stowed so as to facilitate their ready use in emergency, provided with such life-saving equipment including means of sustaining life as is appropriate to the flight to be undertaken;
- b) equipment for making the pyrotechnical distress signals described in Annex 2; and
- c) at the earliest practicable date but not later than 1 January 2018, on all aeroplanes of a maximum certificated take-off mass of over 27 000 kg, a securely attached underwater locating device operating at a frequency of 8.8 kHz. This automatically activated underwater locating device shall operate for a minimum of 30 days and shall not be installed in wings or empennage.

Note.— *Underwater locator beacon (ULB) performance requirements are as contained in the SAE AS6254, Minimum Performance Standard for Low Frequency Underwater Locating Devices (Acoustic) (Self-Powered), or equivalent documents.*

6.5.3.2 Each life jacket and equivalent individual flotation device, when carried in accordance with 6.5.1 a), 6.5.2.1 and 6.5.2.2, shall be equipped with a means of electric illumination for the purpose of facilitating the location of persons, except where the requirement of 6.5.2.1 c) is met by the provision of individual flotation devices other than life jackets.

6.6 All aeroplanes on flights over designated land areas

Aeroplanes, when operated across land areas which have been designated by the State concerned as areas in which search and rescue would be especially difficult, shall be equipped with such signalling devices and life-saving equipment (including means of sustaining life) as may be appropriate to the area overflown.

6.7 All aeroplanes on high altitude flights

Note.— *Approximate altitude in the Standard Atmosphere corresponding to the value of absolute pressure used in this text is as follows:*

Absolute pressure	Metres	Feet
700 hPa	3 000	10 000
620 hPa	4 000	13 000
376 hPa	7 600	25 000

6.7.1 An aeroplane intended to be operated at flight altitudes at which the atmospheric pressure is less than 700 hPa in personnel compartments shall be equipped with oxygen storage and dispensing apparatus capable of storing and dispensing the oxygen supplies required in 4.3.9.1.

6.7.2 An aeroplane intended to be operated at flight altitudes at which the atmospheric pressure is less than 700 hPa but which is provided with means of maintaining pressures greater than 700 hPa in personnel compartments shall be provided with oxygen storage and dispensing apparatus capable of storing and dispensing the oxygen supplies required in 4.3.9.2.

6.7.3 Pressurized aeroplanes newly introduced into service on or after 1 July 1962 and intended to be operated at flight altitudes at which the atmospheric pressure is less than 376 hPa shall be equipped with a device to provide positive warning to the pilot of any dangerous loss of pressurization.

6.7.4 **Recommendation.**— *Pressurized aeroplanes introduced into service before 1 July 1962 and intended to be operated at flight altitudes at which the atmospheric pressure is less than 376 hPa should be equipped with a device to provide positive warning to the pilot of any dangerous loss of pressurization.*

6.7.5 An aeroplane intended to be operated at flight altitudes at which the atmospheric pressure is less than 376 hPa, or which, if operated at flight altitudes at which the atmospheric pressure is more than 376 hPa, cannot descend safely within four minutes to a flight altitude at which the atmospheric pressure is equal to 620 hPa and for which the individual certificate of airworthiness is first issued on or after 9 November 1998, shall be provided with automatically deployable oxygen equipment to satisfy the requirements of 4.3.9.2. The total number of oxygen dispensing units shall exceed the number of passenger and cabin crew seats by at least 10 per cent.

6.7.6 **Recommendation.**— *An aeroplane intended to be operated at flight altitudes at which the atmospheric pressure is less than 376 hPa, or which, if operated at flight altitudes at which the atmospheric pressure is more than 376 hPa cannot descend safely within four minutes to a flight altitude at which the atmospheric pressure is equal to 620 hPa, and for which the individual certificate of airworthiness was first issued before 9 November 1998, should be provided with automatically deployable oxygen equipment to satisfy the requirements of 4.3.9.2. The total number of oxygen dispensing units should exceed the number of passenger and cabin crew seats by at least 10 per cent.*

6.8 All aeroplanes in icing conditions

All aeroplanes shall be equipped with suitable de-icing and/or anti-icing devices when operated in circumstances in which icing conditions are reported to exist or are expected to be encountered.

6.9 All aeroplanes operated in accordance with instrument flight rules

6.9.1 All aeroplanes when operated in accordance with the instrument flight rules, or when the aeroplane cannot be maintained in a desired attitude without reference to one or more flight instruments, shall be equipped with:

- a) a magnetic compass;
- b) an accurate timepiece indicating the time in hours, minutes and seconds;
- c) two sensitive pressure altimeters with counter drum-pointer or equivalent presentation;

Note.— *Neither three-pointer nor drum-pointer altimeters satisfy the requirement in 6.9.1 c).*

- d) an airspeed indicating system with means of preventing malfunctioning due to either condensation or icing;
- e) a turn and slip indicator;
- f) an attitude indicator (artificial horizon);
- g) a heading indicator (directional gyroscope);

Note.— *The requirements of 6.9.1 e), f) and g) may be met by combinations of instruments or by integrated flight director systems provided that the safeguards against total failure, inherent in the three separate instruments, are retained.*

- h) a means of indicating whether the power supply to the gyroscopic instrument is adequate;
- i) a means of indicating in the flight crew compartment the outside air temperature;
- j) a rate-of-climb and descent indicator; and
- k) such additional instruments or equipment as may be prescribed by the appropriate authority.

6.9.2 All aeroplanes over 5 700 kg — Emergency power supply for electrically operated attitude indicating instruments

6.9.2.1 All aeroplanes of a maximum certificated take-off mass of over 5 700 kg newly introduced into service after 1 January 1975 shall be fitted with an emergency power supply, independent of the main electrical generating system, for the purpose of operating and illuminating, for a minimum period of 30 minutes, an attitude indicating instrument (artificial horizon), clearly visible to the pilot-in-command. The emergency power supply shall be automatically operative after the total failure of the main electrical generating system and clear indication shall be given on the instrument panel that the attitude indicator(s) is being operated by emergency power.

6.9.2.2 Those instruments that are used by any one pilot shall be so arranged as to permit the pilot to see their indications readily from his or her station, with the minimum practicable deviation from the position and line of vision normally assumed when looking forward along the flight path.

6.10 All aeroplanes when operated at night

All aeroplanes when operated at night shall be equipped with:

- a) all equipment specified in 6.9;
- b) the lights required by Annex 2 for aircraft in flight or operating on the movement area of an aerodrome;

Note.— Specifications for lights meeting the requirements of Annex 2 for navigation lights are contained in Appendix 1. The general characteristics of lights are specified in Annex 8. Detailed specifications for lights meeting the requirements of Annex 2 for aircraft in flight or operating on the movement area of an aerodrome are contained in the Airworthiness Manual (Doc 9760).

- c) two landing lights;

Note.— Aeroplanes not certificated in accordance with Annex 8 which are equipped with a single landing light having two separately energized filaments will be considered to have complied with 6.10 c).

- d) illumination for all instruments and equipment that are essential for the safe operation of the aeroplane that are used by the flight crew;
- e) lights in all passenger compartments; and
- f) an electric torch for each crew member station.

6.11 Pressurized aeroplanes when carrying passengers — weather radar

Recommendation.— *Pressurized aeroplanes when carrying passengers should be equipped with operative weather radar whenever such aeroplanes are being operated in areas where thunderstorms or other potentially hazardous weather conditions, regarded as detectable with airborne weather radar, may be expected to exist along the route either at night or under instrument meteorological conditions.*

6.12 All aeroplanes operated above 15 000 m (49 000 ft) — radiation indicator

All aeroplanes intended to be operated above 15 000 m (49 000 ft) shall carry equipment to measure and indicate continuously the dose rate of total cosmic radiation being received (i.e. the total of ionizing and neutron radiation of galactic and solar origin) and the cumulative dose on each flight. The display unit of the equipment shall be readily visible to a flight crew member.

Note.— *The equipment is calibrated on the basis of assumptions acceptable to the appropriate national authorities.*

6.13 All aeroplanes complying with the noise certification Standards in Annex 16, Volume I

An aeroplane shall carry a document attesting noise certification. When the document, or a suitable statement attesting noise certification as contained in another document approved by the State of Registry, is issued in a language other than English, it shall include an English translation.

Note.— *The attestation may be contained in any document, carried on board, approved by the State of Registry.*

6.14 Mach number indicator

All aeroplanes with speed limitations expressed in terms of Mach number shall be equipped with a Mach number indicator.

Note.— *This does not preclude the use of the airspeed indicator to derive Mach number for ATS purposes.*

6.15 Aeroplanes required to be equipped with ground proximity warning systems (GPWS)

6.15.1 All turbine-engined aeroplanes of a maximum certificated take-off mass in excess of 5 700 kg or authorized to carry more than nine passengers shall be equipped with a ground proximity warning system.

6.15.2 All turbine-engined aeroplanes of a maximum certificated take-off mass in excess of 15 000 kg or authorized to carry more than 30 passengers shall be equipped with a ground proximity warning system which has a forward looking terrain avoidance function.

6.15.3 All turbine-engined aeroplanes of a maximum certificated take-off mass in excess of 5 700 kg or authorized to carry more than nine passengers, for which the individual certificate of airworthiness is first issued on or after 1 January 2004, shall be equipped with a ground proximity warning system which has a forward looking terrain avoidance function.

6.15.4 From 1 January 2007, all turbine-engined aeroplanes of a maximum certificated take-off mass in excess of 5 700 kg or authorized to carry more than nine passengers shall be equipped with a ground proximity warning system which has a forward looking terrain avoidance function.

6.15.5 **Recommendation.**— *All turbine-engined aeroplanes of a maximum certificated take-off mass of 5 700 kg or less and authorized to carry more than five but not more than nine passengers should be equipped with a ground proximity warning system which provides the warnings of 6.15.8 a) and c), warning of unsafe terrain clearance and a forward looking terrain avoidance function.*

6.15.6 From 1 January 2007, all piston-engined aeroplanes of a maximum certificated take-off mass in excess of 5 700 kg or authorized to carry more than nine passengers shall be equipped with a ground proximity warning system which provides the warnings in 6.15.8 a) and c), warning of unsafe terrain clearance and a forward looking terrain avoidance function.

6.15.7 A ground proximity warning system shall provide automatically a timely and distinctive warning to the flight crew when the aeroplane is in potentially hazardous proximity to the earth's surface.

6.15.8 A ground proximity warning system shall provide, unless otherwise specified herein, warnings of the following circumstances:

- a) excessive descent rate;
- b) excessive terrain closure rate;
- c) excessive altitude loss after take-off or go-around;
- d) unsafe terrain clearance while not in landing configuration:
 - 1) gear not locked down;
 - 2) flaps not in a landing position; and
- e) excessive descent below the instrument glide path.

6.16 Aeroplanes carrying passengers — cabin crew seats

6.16.1 Aeroplanes for which the individual certificate of airworthiness is first issued on or after 1 January 1981

All aeroplanes shall be equipped with a forward or rearward facing (within 15 degrees of the longitudinal axis of the aeroplane) seat, fitted with a safety harness for the use of each cabin crew member required to satisfy the intent of 12.1 in respect of emergency evacuation.

6.16.2 Aeroplanes for which the individual certificate of airworthiness was first issued before 1 January 1981

Recommendation.— *All aeroplanes should be equipped with a forward or rearward facing (within 15 degrees of the longitudinal axis of the aeroplane) seat, fitted with a safety harness for the use of each cabin crew member required to satisfy the intent of 12.1 in respect of emergency evacuation.*

Note.— *Safety harness includes shoulder straps and a seat belt which may be used independently.*

6.16.3 Cabin crew seats provided in accordance with 6.16.1 and 6.16.2 shall be located near floor level and other emergency exits as required by the State of Registry for emergency evacuation.

6.17 Emergency locator transmitter (ELT)

6.17.1 **Recommendation.**— *All aeroplanes should carry an automatic ELT.*

6.17.2 Except as provided for in 6.17.3, from 1 July 2008, all aeroplanes authorized to carry more than 19 passengers shall be equipped with at least one automatic ELT or two ELTs of any type.

6.17.3 All aeroplanes authorized to carry more than 19 passengers for which the individual certificate of airworthiness is first issued after 1 July 2008 shall be equipped with at least two ELTs, one of which shall be automatic.

6.17.4 Except as provided for in 6.17.5, from 1 July 2008, all aeroplanes authorized to carry 19 passengers or less shall be equipped with at least one ELT of any type.

6.17.5 All aeroplanes authorized to carry 19 passengers or less for which the individual certificate of airworthiness is first issued after 1 July 2008 shall be equipped with at least one automatic ELT.

6.17.6 ELT equipment carried to satisfy the requirements of 6.17.1, 6.17.2, 6.17.3, 6.17.4 and 6.17.5 shall operate in accordance with the relevant provisions of Annex 10, Volume III.

Note.— *The judicious choice of numbers of ELTs, their type and placement on aircraft and associated floatable life support systems will ensure the greatest chance of ELT activation in the event of an accident for aircraft operating over water or land, including areas especially difficult for search and rescue. Placement of transmitter units is a vital factor in ensuring optimal crash and fire protection. The placement of the control and switching devices (activation monitors) of automatic fixed ELTs and their associated operational procedures will also take into consideration the need for rapid detection of inadvertent activation and convenient manual switching by crew members.*

6.18 Aeroplanes required to be equipped with an airborne collision avoidance system (ACAS II)

6.18.1 From 1 January 2003, all turbine-engined aeroplanes of a maximum certificated take-off mass in excess of 15 000 kg or authorized to carry more than 30 passengers shall be equipped with an airborne collision avoidance system (ACAS II).

6.18.2 From 1 January 2005, all turbine-engined aeroplanes of a maximum certificated take-off mass in excess of 5 700 kg or authorized to carry more than 19 passengers shall be equipped with an airborne collision avoidance system (ACAS II).

6.18.3 **Recommendation.**— *All aeroplanes should be equipped with an airborne collision avoidance system (ACAS II).*

6.18.4 An airborne collision avoidance system shall operate in accordance with the relevant provisions of Annex 10, Volume IV.

6.19 Requirements for pressure-altitude reporting transponders

6.19.1 All aeroplanes shall be equipped with a pressure-altitude reporting transponder which operates in accordance with the relevant provisions of Annex 10, Volume IV.

6.19.2 All aeroplanes for which the individual certificate of airworthiness is first issued after 1 January 2009 shall be equipped with a data source that provides pressure-altitude information with a resolution of 7.62 m (25 ft), or better.

6.19.3 After 1 January 2012, all aeroplanes shall be equipped with a data source that provides pressure-altitude information with a resolution of 7.62 m (25 ft), or better.

6.19.4 **Recommendation.** *The Mode S transponder should be provided with the airborne/on-the-ground status if the aeroplane is equipped with an automatic means of detecting such status.*

Note 1.— These provisions will improve the effectiveness of airborne collision avoidance systems as well as air traffic services that employ Mode S radar. In particular, tracking processes are significantly enhanced with a resolution of 7.62 m (25 ft), or better.

Note 2.— Mode C replies of transponders always report pressure altitude in 30.50 m (100 ft) increments irrespective of the resolution of the data source.

6.20 Microphones

All flight crew members required to be on flight deck duty shall communicate through boom or throat microphones below the transition level/altitude.

6.21 Turbo-jet aeroplanes — forward-looking wind shear warning system

6.21.1 **Recommendation.**— *All turbo-jet aeroplanes of a maximum certificated take-off mass in excess of 5 700 kg or authorized to carry more than nine passengers should be equipped with a forward-looking wind shear warning system.*

6.21.2 **Recommendation.**— *A forward-looking wind shear warning system should be capable of providing the pilot with a timely aural and visual warning of wind shear ahead of the aircraft, and the information required to permit the pilot to safely commence and continue a missed approach or go-around or to execute an escape manoeuvre if necessary. The system should also provide an indication to the pilot when the limits specified for the certification of automatic landing equipment are being approached, when such equipment is in use.*

6.22 All aeroplanes operated by a single pilot under the instrument flight rules (IFR) or at night

For approval in accordance with 4.9.1, all aeroplanes operated by a single pilot under the IFR or at night shall be equipped with:

- a) a serviceable autopilot that has at least altitude hold and heading select modes;
- b) a headset with a boom microphone or equivalent; and
- c) means of displaying charts that enables them to be readable in all ambient light conditions.

**6.23 Aeroplanes equipped with head-up displays (HUD)
and/or enhanced vision systems (EVS)**

Where aeroplanes are equipped with HUD and/or EVS, the use of such systems to gain operational benefit shall be approved by the State of the Operator.

Note.— Guidance on HUD and EVS is contained in Attachment J.

CHAPTER 7. AEROPLANE COMMUNICATION AND NAVIGATION EQUIPMENT

7.1 Communication equipment

7.1.1 An aeroplane shall be provided with radio communication equipment capable of:

- a) conducting two-way communication for aerodrome control purposes;
- b) receiving meteorological information at any time during flight; and
- c) conducting two-way communication at any time during flight with at least one aeronautical station and with such other aeronautical stations and on such frequencies as may be prescribed by the appropriate authority.

Note.— The requirements of 7.1.1 are considered fulfilled if the ability to conduct the communications specified therein is established during radio propagation conditions which are normal for the route.

7.1.2 The radio communication equipment required in accordance with 7.1.1 shall provide for communications on the aeronautical emergency frequency 121.5 MHz.

7.1.3 For flights in defined portions of airspace or on routes where an RCP type has been prescribed, an aeroplane shall, in addition to the requirements specified in 7.1.1:

- a) be provided with communication equipment which will enable it to operate in accordance with the prescribed RCP type(s); and
- b) be authorized by the State of the Operator for operations in such airspace.

Note.— Information on RCP and associated procedures, and guidance concerning the approval process, are contained in the Manual on Required Communications Performance (RCP) (Doc 9869). This document also contains references to other documents produced by States and international bodies concerning communication systems and RCP.

7.2 Navigation equipment

7.2.1 An aeroplane shall be provided with navigation equipment which will enable it to proceed:

- a) in accordance with its operational flight plan; and
- b) in accordance with the requirements of air traffic services;

except when, if not so precluded by the appropriate authority, navigation for flights under the visual flight rules is accomplished by visual reference to landmarks.

7.2.2 For operations where a navigation specification for performance-based navigation has been prescribed, an aeroplane shall, in addition to the requirements specified in 7.2.1:

- a) be provided with navigation equipment which will enable it to operate in accordance with the prescribed navigation specification(s); and
- b) be authorized by the State of the Operator for such operations.

Note.— Information on performance-based navigation, and guidance concerning the implementation and operational approval process, are contained in the Performance-based Navigation (PBN) Manual (Doc 9613). This document also contains a comprehensive list of references to other documents produced by States and international bodies concerning navigation systems.

7.2.3 For flights in defined portions of airspace where, based on Regional Air Navigation Agreement, minimum navigation performance specifications (MNPS) are prescribed, an aeroplane shall be provided with navigation equipment which:

- a) continuously provides indications to the flight crew of adherence to or departure from track to the required degree of accuracy at any point along that track; and
- b) has been authorized by the State of the Operator for the MNPS operations concerned.

Note.— The prescribed minimum navigation performance specifications and the procedures governing their application are published in the Regional Supplementary Procedures (Doc 7030).

7.2.4 For flights in defined portions of airspace where, based on Regional Air Navigation Agreement, a reduced vertical separation minimum (RVSM) of 300 m (1 000 ft) is applied between FL 290 and FL 410 inclusive, an aeroplane:

- a) shall be provided with equipment which is capable of:
 - 1) indicating to the flight crew the flight level being flown;
 - 2) automatically maintaining a selected flight level;
 - 3) providing an alert to the flight crew when a deviation occurs from the selected flight level. The threshold for the alert shall not exceed ± 90 m (300 ft); and
 - 4) automatically reporting pressure-altitude;
- b) shall be authorized by the State of the Operator for operation in the airspace concerned; and
- c) shall demonstrate a vertical navigation performance in accordance with Appendix 4.

7.2.5 Prior to granting the RVSM approval required in accordance with 7.2.4 b), the State shall be satisfied that:

- a) the vertical navigation performance capability of the aeroplane satisfies the requirements specified in Appendix 4;
- b) the operator has instituted appropriate procedures in respect of continued airworthiness (maintenance and repair) practices and programmes; and
- c) the operator has instituted appropriate flight crew procedures for operations in RVSM airspace.

Note.— An RVSM approval is valid globally on the understanding that any operating procedures specific to a given region will be stated in the operations manual or appropriate crew guidance.

7.2.6 The State of the Operator, in consultation with the State of Registry if appropriate, shall ensure that, in respect of those aeroplanes mentioned in 7.2.4, adequate provisions exist for:

- a) receiving the reports of height-keeping performance issued by the monitoring agencies established in accordance with Annex 11, 3.3.4.1; and
- b) taking immediate corrective action for individual aircraft, or aircraft type groups, identified in such reports as not complying with the height-keeping requirements for operation in airspace where RVSM is applied.

7.2.7 The State of the Operator that has issued an RVSM approval to an operator shall establish a requirement which ensures that a minimum of two aeroplanes of each aircraft type grouping of the operator have their height-keeping performance monitored, at least once every two years or within intervals of 1 000 flight hours per aeroplane, whichever period is longer. If an operator aircraft type grouping consists of a single aeroplane, monitoring of that aeroplane shall be accomplished within the specified period.

Note.— Monitoring data from any regional monitoring programme established in accordance with Annex 11, 3.3.5.2, may be used to satisfy the requirement.

7.2.8 All States that are responsible for airspace where RVSM has been implemented, or that have issued RVSM approvals to operators within their State, shall establish provisions and procedures which ensure that appropriate action will be taken in respect of aircraft and operators found to be operating in RVSM airspace without a valid RVSM approval.

Note 1.— These provisions and procedures need to address both the situation where the aircraft in question is operating without approval in the airspace of the State, and the situation where an operator for which the State has regulatory oversight responsibility is found to be operating without the required approval in the airspace of another State.

Note 2.— Guidance material relating to the approval for operation in RVSM airspace is contained in the Manual on Implementation of a 300 m (1 000 ft) Vertical Separation Minimum Between FL 290 and FL 410 Inclusive (Doc 9574).

7.2.9 The aeroplane shall be sufficiently provided with navigation equipment to ensure that, in the event of the failure of one item of equipment at any stage of the flight, the remaining equipment will enable the aeroplane to navigate in accordance with 7.2.1 and, where applicable, 7.2.2, 7.2.3 and 7.2.4.

Note.— Guidance material relating to aircraft equipment necessary for flight in airspace where RVSM is applied is contained in the Manual on Implementation of a 300 m (1 000 ft) Vertical Separation Minimum Between FL 290 and FL 410 Inclusive (Doc 9574).

7.2.10 On flights in which it is intended to land in instrument meteorological conditions, an aeroplane shall be provided with radio equipment capable of receiving signals providing guidance to a point from which a visual landing can be effected. This equipment shall be capable of providing such guidance for each aerodrome at which it is intended to land in instrument meteorological conditions and for any designated alternate aerodromes.

7.3 Installation

The equipment installation shall be such that the failure of any single unit required for either communications or navigation purposes or both will not result in the failure of another unit required for communications or navigation purposes.

7.4 Electronic navigation data management

7.4.1 An operator shall not employ electronic navigation data products that have been processed for application in the air and on the ground unless the State of the Operator has approved the operator's procedures for ensuring that the process applied and the products delivered have met acceptable standards of integrity and that the products are compatible with the intended function of the equipment that will use them. The State of the Operator shall ensure that the operator continues to monitor both process and products.

Note.— Guidance relating to the processes that data suppliers may follow is contained in RTCA DO200A/EUROCAE ED-76 and RTCA DO-201A/EUROCAE ED-77.

7.4.2 An operator shall implement procedures that ensure the timely distribution and insertion of current and unaltered electronic navigation data to all aircraft that require it.

CHAPTER 8. AEROPLANE MAINTENANCE

Note 1.— For the purpose of this chapter, “aeroplane” includes: engines, propellers, components, accessories, instruments, equipment and apparatus including emergency equipment.

Note 2.— Reference is made throughout this chapter to the requirements of the State of Registry. When the State of the Operator is not the same as the State of Registry, it may be necessary to consider any additional requirements of the State of the Operator.

Note 3.— Guidance on continuing airworthiness requirements is contained in the Airworthiness Manual (Doc 9760).

8.1 Operator’s maintenance responsibilities

8.1.1 Operators shall ensure that, in accordance with procedures acceptable to the State of Registry:

- a) each aeroplane they operate is maintained in an airworthy condition;
- b) the operational and emergency equipment necessary for an intended flight is serviceable; and
- c) the certificate of airworthiness of each aeroplane they operate remains valid.

8.1.2 An operator shall not operate an aeroplane unless it is maintained and released to service by an organization approved in accordance with 8.7, or under an equivalent system, either of which shall be acceptable to the State of Registry.

8.1.3 When the State of Registry accepts an equivalent system, the person signing the maintenance release shall be licensed in accordance with Annex 1.

8.1.4 An operator shall employ a person or group of persons to ensure that all maintenance is carried out in accordance with the maintenance control manual.

8.1.5 The operator shall ensure that the maintenance of its aeroplanes is performed in accordance with the maintenance programme.

8.2 Operator’s maintenance control manual

8.2.1 The operator shall provide, for the use and guidance of maintenance and operational personnel concerned, a maintenance control manual, acceptable to the State of Registry, in accordance with the requirements of 11.2. The design of the manual shall observe Human Factors principles.

Note.— Guidance material on the application of Human Factors principles can be found in the Human Factors Training Manual (Doc 9683).

8.2.2 The operator shall ensure that the maintenance control manual is amended as necessary to keep the information contained therein up to date.

8.2.3 Copies of all amendments to the operator's maintenance control manual shall be furnished promptly to all organizations or persons to whom the manual has been issued.

8.2.4 The operator shall provide the State of the Operator and the State of Registry with a copy of the operator's maintenance control manual, together with all amendments and/or revisions to it and shall incorporate in it such mandatory material as the State of the Operator or the State of Registry may require.

8.3 Maintenance programme

8.3.1 The operator shall provide, for the use and guidance of maintenance and operational personnel concerned, a maintenance programme, approved by the State of Registry, containing the information required by 11.3. The design and application of the operator's maintenance programme shall observe Human Factors principles.

Note.— Guidance material on the application of Human Factors principles can be found in the Human Factors Training Manual (Doc 9683).

8.3.2 Copies of all amendments to the maintenance programme shall be furnished promptly to all organizations or persons to whom the maintenance programme has been issued.

8.4 Maintenance records

8.4.1 An operator shall ensure that the following records are kept for the periods mentioned in 8.4.2:

- a) the total time in service (hours, calendar time and cycles, as appropriate) of the aeroplane and all life-limited components;
- b) the current status of compliance with all mandatory continuing airworthiness information;
- c) appropriate details of modifications and repairs;
- d) the time in service (hours, calendar time and cycles, as appropriate) since the last overhaul of the aeroplane or its components subject to a mandatory overhaul life;
- e) the current status of the aeroplane's compliance with the maintenance programme; and
- f) the detailed maintenance records to show that all requirements for the signing of a maintenance release have been met.

8.4.2 The records in 8.4.1 a) to e) shall be kept for a minimum period of 90 days after the unit to which they refer has been permanently withdrawn from service, and the records in 8.4.1 f) for a minimum period of one year after the signing of the maintenance release.

8.4.3 In the event of a temporary change of operator, the records shall be made available to the new operator. In the event of any permanent change of operator, the records shall be transferred to the new operator.

Note.— In the context of 8.4.3, a judgement on what should be considered as a temporary change of operator will need to be made by the State of Registry in the light of the need to exercise control over the records, which will depend on access to them and the opportunity to update them.

8.5 Continuing airworthiness information

8.5.1 The operator of an aeroplane over 5 700 kg maximum certificated take-off mass shall monitor and assess maintenance and operational experience with respect to continuing airworthiness and provide the information as prescribed by the State of Registry and report through the system specified in Annex 8, Part II, 4.2.3 f) and 4.2.4.

8.5.2 The operator of an aeroplane over 5 700 kg maximum certificated take-off mass shall obtain and assess continuing airworthiness information and recommendations available from the organization responsible for the type design and shall implement resulting actions considered necessary in accordance with a procedure acceptable to the State of Registry.

Note.— Guidance on the interpretation of “the organization responsible for the type design” is contained in the Airworthiness Manual (Doc 9760).

8.6 Modifications and repairs

All modifications and repairs shall comply with airworthiness requirements acceptable to the State of Registry. Procedures shall be established to ensure that the substantiating data supporting compliance with the airworthiness requirements are retained.

8.7 Approved maintenance organization

8.7.1 Issue of approval

8.7.1.1 The issue of a maintenance organization approval by a State shall be dependent upon the applicant demonstrating compliance with the requirements of 8.7 for such organizations.

8.7.1.2 The approval document shall contain at least the following:

- a) organization's name and location;
- b) date of issue and period of validity;
- c) terms of approval.

8.7.1.3 The continued validity of the approval shall depend upon the organization remaining in compliance with the requirements of 8.7 for an approved maintenance organization.

8.7.2 Maintenance organization's procedures manual

8.7.2.1 The maintenance organization shall provide for the use and guidance of maintenance personnel concerned a procedures manual which may be issued in separate parts containing the following information:

- a) a general description of the scope of work authorized under the organization's terms of approval;
- b) a description of the organization's procedures and quality or inspection system in accordance with 8.7.4;
- c) a general description of the organization's facilities;

- d) names and duties of the person or persons required by 8.7.6.1;
- e) a description of the procedures used to establish the competence of maintenance personnel as required by 8.7.6.3;
- f) a description of the method used for the completion and retention of the maintenance records required by 8.7.7;
- g) a description of the procedures for preparing the maintenance release and the circumstances under which the release is to be signed;
- h) the personnel authorized to sign the maintenance release and the scope of their authorization;
- i) a description, when applicable, of the additional procedures for complying with an operator's maintenance procedures and requirements;
- j) a description of the procedures for complying with the service information reporting requirements of Annex 8, Part II, 4.2.3 f) and 4.2.4; and
- k) a description of the procedure for receiving, assessing, amending and distributing within the maintenance organization all necessary airworthiness data from the type certificate holder or type design organization.

8.7.2.2 The maintenance organization shall ensure that the procedures manual is amended as necessary to keep the information contained therein up to date.

8.7.2.3 Copies of all amendments to the procedures manual shall be furnished promptly to all organizations or persons to whom the manual has been issued.

8.7.3 Safety management

8.7.3.1 States shall establish a State safety programme in order to achieve an acceptable level of safety in civil aviation.

Note.— A framework for the implementation and maintenance of a State safety programme is contained in Attachment I, and guidance on a State safety programme is contained in the Safety Management Manual (SMM) (Doc 9859).

8.7.3.2 The acceptable level of safety to be achieved shall be established by the State.

Note.— Guidance on defining an acceptable level of safety is contained in the Safety Management Manual (SMM) (Doc 9859).

8.7.3.3 States shall require, as part of their State safety programme, that a maintenance organization implement a safety management system acceptable to the State that, as a minimum:

- a) identifies safety hazards;
- b) ensures the implementation of remedial action necessary to maintain agreed safety performance;
- c) provides for continuous monitoring and regular assessment of the safety performance; and
- d) aims at a continuous improvement of the overall performance of the safety management system.

Note.— Guidance on defining safety performance is contained in the Safety Management Manual (SMM) (Doc 9859).

8.7.3.4 A safety management system shall clearly define lines of safety accountability throughout a maintenance organization, including a direct accountability for safety on the part of senior management.

Note.— The framework for the implementation and maintenance of a safety management system is contained in Appendix 7. Guidance on safety management systems is contained in the Safety Management Manual (SMM) (Doc 9859).

8.7.4 Maintenance procedures and quality assurance system

8.7.4.1 The maintenance organization shall establish procedures, acceptable to the State granting the approval, which ensure good maintenance practices and compliance with all relevant requirements of this chapter.

8.7.4.2 The maintenance organization shall ensure compliance with 8.7.4.1 by either establishing an independent quality assurance system to monitor compliance with and adequacy of the procedures, or by providing a system of inspection to ensure that all maintenance is properly performed.

8.7.5 Facilities

8.7.5.1 The facilities and working environment shall be appropriate for the task to be performed.

8.7.5.2 The maintenance organization shall have the necessary technical data, equipment, tools and material to perform the work for which it is approved.

8.7.5.3 Storage facilities shall be provided for parts, equipment, tools and material. Storage conditions shall be such as to provide security and prevent deterioration of and damage to stored items.

8.7.6 Personnel

8.7.6.1 The maintenance organization shall nominate a person or group of persons whose responsibilities include ensuring that the maintenance organization is in compliance with the requirements of 8.7 for an approved maintenance organization.

8.7.6.2 The maintenance organization shall employ the necessary personnel to plan, perform, supervise, inspect and release the work to be performed.

8.7.6.3 The competence of maintenance personnel shall be established in accordance with a procedure and to a level acceptable to the State granting the approval. The person signing a maintenance release shall be qualified in accordance with Annex 1.

8.7.6.4 The maintenance organization shall ensure that all maintenance personnel receive initial and continuation training appropriate to their assigned tasks and responsibilities. The training programme established by the maintenance organization shall include training in knowledge and skills related to human performance, including coordination with other maintenance personnel and flight crew.

Note.— Guidance material to design training programmes to develop knowledge and skills in human performance can be found in the Human Factors Training Manual (Doc 9683).

8.7.7 Records

8.7.7.1 The maintenance organization shall retain detailed maintenance records to show that all requirements for the signing of a maintenance release have been met.

8.7.7.2 The records required by 8.7.7.1 shall be kept for a minimum period of one year after the signing of the maintenance release.

8.8 Maintenance release

8.8.1 A maintenance release shall be completed and signed to certify that the maintenance work performed has been completed satisfactorily and in accordance with approved data and the procedures described in the maintenance organization's procedures manual.

8.8.2 A maintenance release shall contain a certification including:

- a) basic details of the maintenance carried out including detailed reference of the approved data used;
- b) the date such maintenance was completed;
- c) when applicable, the identity of the approved maintenance organization; and
- d) the identity of the person or persons signing the release.

CHAPTER 9. AEROPLANE FLIGHT CREW

9.1 Composition of the flight crew

9.1.1 The number and composition of the flight crew shall not be less than that specified in the operations manual. The flight crews shall include flight crew members in addition to the minimum numbers specified in the flight manual or other documents associated with the certificate of airworthiness, when necessitated by considerations related to the type of aeroplane used, the type of operation involved and the duration of flight between points where flight crews are changed.

9.1.2 Radio operator

The flight crew shall include at least one member who holds a valid licence, issued or rendered valid by the State of Registry, authorizing operation of the type of radio transmitting equipment to be used.

9.1.3 Flight engineer

When a separate flight engineer's station is incorporated in the design of an aeroplane, the flight crew shall include at least one flight engineer especially assigned to that station, unless the duties associated with that station can be satisfactorily performed by another flight crew member, holding a flight engineer licence, without interference with regular duties.

9.1.4 Flight navigator

The flight crew shall include at least one member who holds a flight navigator licence in all operations where, as determined by the State of the Operator, navigation necessary for the safe conduct of the flight cannot be adequately accomplished by the pilots from the pilot station.

9.2 Flight crew member emergency duties

An operator shall, for each type of aeroplane, assign to all flight crew members the necessary functions they are to perform in an emergency or in a situation requiring emergency evacuation. Annual training in accomplishing these functions shall be contained in the operator's training programme and shall include instruction in the use of all emergency and life-saving equipment required to be carried, and drills in the emergency evacuation of the aeroplane.

9.3 Flight crew member training programmes

9.3.1 An operator shall establish and maintain a ground and flight training programme, approved by the State of the Operator, which ensures that all flight crew members are adequately trained to perform their assigned duties. The training programme shall:

- a) include ground and flight training facilities and properly qualified instructors as determined by the State of the Operator;

- b) consist of ground and flight training in the type(s) of aeroplane on which the flight crew member serves;
- c) include proper flight crew coordination and training in all types of emergency and abnormal situations or procedures caused by engine, airframe or systems malfunctions, fire or other abnormalities;
- d) include training in knowledge and skills related to visual and instrument flight procedures for the intended area of operation, human performance including threat and error management and in the transport of dangerous goods;
- e) ensure that all flight crew members know the functions for which they are responsible and the relation of these functions to the functions of other crew members, particularly in regard to abnormal or emergency procedures; and
- f) be given on a recurrent basis, as determined by the State of the Operator and shall include an assessment of competence.

Note 1.— Paragraph 4.2.5 prohibits the in-flight simulation of emergency or abnormal situations when passengers or cargo are being carried.

Note 2.— Flight training may, to the extent deemed appropriate by the State of the Operator, be given in flight simulation training devices approved by the State for that purpose.

Note 3.— The scope of the recurrent training required by 9.2 and 9.3 may be varied and need not be as extensive as the initial training given in a particular type of aeroplane.

Note 4.— The use of correspondence courses and written examinations as well as other means may, to the extent deemed feasible by the State of the Operator, be utilized in meeting the requirements for periodic ground training.

Note 5.— Provisions for training in the transport of dangerous goods are contained in Annex 18.

Note 6.— Guidance material to design training programmes to develop knowledge and skills in human performance can be found in the Human Factors Training Manual (Doc 9683).

Note 7.— Information for pilots and flight operations personnel on flight procedure parameters and operational procedures is contained in PANS-OPS (Doc 8168), Volume I. Criteria for the construction of visual and instrument flight procedures are contained in PANS-OPS (Doc 8168), Volume II. Obstacle clearance criteria and procedures used in certain States may differ from PANS-OPS, and knowledge of these differences is important for safety reasons.

Note 8.— Guidance material to design flight crew training programmes can be found in the Preparation of an Operations Manual (Doc 9376).

Note 9.— Guidance material on the different means used to assess competence can be found in the Attachment to Chapter 2 of the Procedures for Air Navigation Services — Training (PANS-TRG, Doc 9868).

9.3.2 The requirement for recurrent flight training in a particular type of aeroplane shall be considered fulfilled by:

- a) the use, to the extent deemed feasible by the State of the Operator, of flight simulation training devices approved by that State for that purpose; or
- b) the completion within the appropriate period of the proficiency check required by 9.4.4 in that type of aeroplane.

9.4 Qualifications

Note.— See the Manual of Procedures for Establishment and Management of a State's Personnel Licensing System (Doc 9379) for guidance of a general nature on cross-crew qualification, mixed-fleet flying and cross-credit.

9.4.1 Recent experience — pilot-in-command and co-pilot

9.4.1.1 An operator shall not assign a pilot-in-command or a co-pilot to operate at the flight controls of a type or variant of a type of aeroplane during take-off and landing unless that pilot has operated the flight controls during at least three take-offs and landings within the preceding 90 days on the same type of aeroplane or in a flight simulator approved for the purpose.

9.4.1.2 When a pilot-in-command or a co-pilot is flying several variants of the same type of aeroplane or different types of aeroplanes with similar characteristics in terms of operating procedures, systems and handling, the State shall decide under which conditions the requirements of 9.4.1.1 for each variant or each type of aeroplane can be combined.

9.4.2 Recent experience — cruise relief pilot

9.4.2.1 An operator shall not assign a pilot to act in the capacity of cruise relief pilot in a type or variant of a type of aeroplane unless, within the preceding 90 days that pilot has either:

- a) operated as a pilot-in-command, co-pilot or cruise relief pilot on the same type of aeroplane; or
- b) carried out flying skill refresher training including normal, abnormal and emergency procedures specific to cruise flight on the same type of aeroplane or in a flight simulator approved for the purpose, and has practised approach and landing procedures, where the approach and landing procedure practice may be performed as the pilot who is not flying the aeroplane.

9.4.2.2 When a cruise relief pilot is flying several variants of the same type of aeroplane or different types of aeroplanes with similar characteristics in terms of operating procedures, systems and handling, the State shall decide under which conditions the requirements of 9.4.2.1 for each variant or each type of aeroplane can be combined.

9.4.3 Pilot-in-command area, route and aerodrome qualification

9.4.3.1 An operator shall not utilize a pilot as pilot-in-command of an aeroplane on a route or route segment for which that pilot is not currently qualified until such pilot has complied with 9.4.3.2 and 9.4.3.3.

9.4.3.2 Each such pilot shall demonstrate to the operator an adequate knowledge of:

- a) the route to be flown, and the aerodromes which are to be used. This shall include knowledge of:
 - 1) the terrain and minimum safe altitudes;
 - 2) the seasonal meteorological conditions;
 - 3) the meteorological, communication and air traffic facilities, services and procedures;
 - 4) the search and rescue procedures; and
 - 5) the navigational facilities and procedures, including any long-range navigation procedures, associated with the route along which the flight is to take place; and

- b) procedures applicable to flight paths over heavily populated areas and areas of high air traffic density, obstructions, physical layout, lighting, approach aids and arrival, departure, holding and instrument approach procedures, and applicable operating minima.

Note.— That portion of the demonstration relating to arrival, departure, holding and instrument approach procedures may be accomplished in an appropriate training device which is adequate for this purpose.

9.4.3.3 A pilot-in-command shall have made an actual approach into each aerodrome of landing on the route, accompanied by a pilot who is qualified for the aerodrome, as a member of the flight crew or as an observer on the flight deck, unless:

- a) the approach to the aerodrome is not over difficult terrain and the instrument approach procedures and aids available are similar to those with which the pilot is familiar, and a margin to be approved by the State of the Operator is added to the normal operating minima, or there is reasonable certainty that approach and landing can be made in visual meteorological conditions; or
- b) the descent from the initial approach altitude can be made by day in visual meteorological conditions; or
- c) the operator qualifies the pilot-in-command to land at the aerodrome concerned by means of an adequate pictorial presentation; or
- d) the aerodrome concerned is adjacent to another aerodrome at which the pilot-in-command is currently qualified to land.

9.4.3.4 The operator shall maintain a record, sufficient to satisfy the State of the Operator of the qualification of the pilot and of the manner in which such qualification has been achieved.

9.4.3.5 An operator shall not continue to utilize a pilot as a pilot-in-command on a route or within an area specified by the operator and approved by the State of the Operator unless, within the preceding 12 months, that pilot has made at least one trip as a pilot member of the flight crew, or as a check pilot, or as an observer in the flight crew compartment:

- a) within that specified area; and
- b) if appropriate, on any route where procedures associated with that route or with any aerodromes intended to be used for take-off or landing require the application of special skills or knowledge.

9.4.3.6 In the event that more than 12 months elapse in which a pilot-in-command has not made such a trip on a route in close proximity and over similar terrain, within such a specified area, route or aerodrome, and has not practised such procedures in a training device which is adequate for this purpose, prior to again serving as a pilot-in-command within that area or on that route, that pilot must requalify in accordance with 9.4.3.2 and 9.4.3.3.

9.4.4 Pilot proficiency checks

9.4.4.1 An operator shall ensure that piloting technique and the ability to execute emergency procedures is checked in such a way as to demonstrate the pilot's competence on each type or variant of a type of aeroplane. Where the operation may be conducted under instrument flight rules, an operator shall ensure that the pilot's competence to comply with such rules is demonstrated to either a check pilot of the operator or to a representative of the State of the Operator. Such checks shall be performed twice within any period of one year. Any two such checks which are similar and which occur within a period of four consecutive months shall not alone satisfy this requirement.

Note 1.— Flight simulation training devices approved by the State of the Operator may be used for those parts of the checks for which they are specifically approved.

Note 2.— See the Manual of Criteria for the Qualification of Flight Simulation Training Devices (Doc 9625).

9.4.4.2 When an operator schedules flight crew on several variants of the same type of aeroplane or different types of aeroplanes with similar characteristics in terms of operating procedures, systems and handling, the State shall decide under which conditions the requirements of 9.4.4.1 for each variant or each type of aeroplane can be combined.

9.4.5 Single pilot operations under the instrument flight rules (IFR) or at night

9.4.5.1 The State of the Operator shall prescribe requirements of experience, recency and training applicable to single pilot operations intended to be carried out under the IFR or at night.

9.4.5.2 **Recommendation.**— *The pilot-in-command should:*

- a) *for operations under the IFR or at night, have accumulated at least 50 hours flight time on the class of aeroplane, of which at least 10 hours shall be as pilot-in-command;*
- b) *for operations under the IFR, have accumulated at least 25 hours flight time under the IFR on the class of aeroplane, which may form part of the 50 hours flight time in sub-paragraph a);*
- c) *for operations at night, have accumulated at least 15 hours flight time at night, which may form part of the 50 hours flight time in sub-paragraph a);*
- d) *for operations under the IFR, have acquired recent experience as a pilot engaged in a single pilot operation under the IFR of:*
 - i) *at least five IFR flights, including three instrument approaches carried out during the preceding 90 days on the class of aeroplane in the single pilot role; or*
 - ii) *an IFR instrument approach check carried out on such an aeroplane during the preceding 90 days;*
- e) *for operations at night, have made at least three take-offs and landings at night on the class of aeroplane in the single pilot role in the preceding 90 days; and*
- f) *have successfully completed training programmes that include, in addition to the requirements of 9.3, passenger briefing with respect to emergency evacuation, autopilot management, and the use of simplified in-flight documentation.*

9.4.5.3 The initial and recurrent flight training and proficiency checks indicated in 9.3.1 and 9.4.4 shall be performed by the pilot-in-command in the single pilot role on the class of aeroplane in an environment representative of the operation.

9.5 Flight crew equipment

A flight crew member assessed as fit to exercise the privileges of a licence, subject to the use of suitable correcting lenses, shall have a spare set of the correcting lenses readily available when exercising those privileges.

CHAPTER 10. FLIGHT OPERATIONS OFFICER/ FLIGHT DISPATCHER

10.1 When the State of the Operator requires that a flight operations officer/flight dispatcher, employed in conjunction with an approved method of control and supervision of flight operations, be licensed, that flight operations officer/flight dispatcher shall be licensed in accordance with the provisions of Annex 1.

10.2 In accepting proof of qualifications other than the option of holding of a flight operations officer/flight dispatcher licence, the State of the Operator, in accordance with the approved method of control and supervision of flight operations, shall require that, as a minimum, such persons meet the requirements specified in Annex 1 for the flight operations officer/flight dispatcher licence.

10.3 A flight operations officer/flight dispatcher shall not be assigned to duty unless that person has:

- a) satisfactorily completed an operator-specific training course that addresses all the specific components of its approved method of control and supervision of flight operations specified in 4.2.1.3;

Note.— Guidance on the composition of such training syllabi is provided in the Training Manual (Doc 7192), Part D-3 — Flight Operations Officers/Flight Dispatchers.

- b) made, within the preceding 12 months, at least a one-way qualification flight in the flight crew compartment of an aeroplane over any area for which that individual is authorized to exercise flight supervision. The flight should include landings at as many aerodromes as practicable;

Note.— For the purpose of the qualification flight, the flight operations officer/flight dispatcher must be able to monitor the flight crew intercommunication system and radio communications, and be able to observe the actions of the flight crew.

- c) demonstrated to the operator a knowledge of:
 - 1) the contents of the operations manual described in Appendix 2;
 - 2) the radio equipment in the aeroplanes used; and
 - 3) the navigation equipment in the aeroplanes used;
- d) demonstrated to the operator a knowledge of the following details concerning operations for which the officer is responsible and areas in which that individual is authorized to exercise flight supervision:
 - 1) the seasonal meteorological conditions and the sources of meteorological information;
 - 2) the effects of meteorological conditions on radio reception in the aeroplanes used;
 - 3) the peculiarities and limitations of each navigation system which is used by the operation; and
 - 4) the aeroplane loading instructions;

- e) demonstrated to the operator knowledge and skills related to human performance relevant to dispatch duties; and
- f) demonstrated to the operator the ability to perform the duties specified in 4.6.

10.4 **Recommendation.**— *A flight operations officer/flight dispatcher assigned to duty should maintain complete familiarization with all features of the operation which are pertinent to such duties, including knowledge and skills related to human performance.*

Note.— *Guidance material to design training programmes to develop knowledge and skills in human performance can be found in the Human Factors Training Manual (Doc 9683).*

10.5 **Recommendation.**— *A flight operations officer/flight dispatcher should not be assigned to duty after 12 consecutive months of absence from such duty, unless the provisions of 10.2 are met.*

CHAPTER 11. MANUALS, LOGS AND RECORDS

Note.— The following additional manuals, logs and records are associated with this Annex but are not included in this chapter:

Fuel and oil records — see 4.2.10

Maintenance records — see 8.4

Flight time records — see 4.2.11.3

Flight preparation forms — see 4.3

Operational flight plan — see 4.3.3.1

Pilot-in-command route and airport qualification records — see 9.4.3.4.

11.1 Flight manual

Note.— The flight manual contains the information specified in Annex 8.

The flight manual shall be updated by implementing changes made mandatory by the State of Registry.

11.2 Operator's maintenance control manual

The operator's maintenance control manual provided in accordance with 8.2, which may be issued in separate parts, shall contain the following information:

- a) a description of the procedures required by 8.1.1 including, when applicable:
 - 1) a description of the administrative arrangements between the operator and the approved maintenance organization;
 - 2) a description of the maintenance procedures and the procedures for completing and signing a maintenance release when maintenance is based on a system other than that of an approved maintenance organization.
- b) names and duties of the person or persons required by 8.1.4;
- c) a reference to the maintenance programme required by 8.3.1;
- d) a description of the methods used for the completion and retention of the operator's maintenance records required by 8.4;
- e) a description of the procedures for monitoring, assessing and reporting maintenance and operational experience required by 8.5.1;

- f) a description of the procedures for complying with the service information reporting requirements of Annex 8, Part II, 4.2.3 f) and 4.2.4;
- g) a description of procedures for assessing continuing airworthiness information and implementing any resulting actions, as required by 8.5.2;
- h) a description of the procedures for implementing action resulting from mandatory continuing airworthiness information;
- i) a description of establishing and maintaining a system of analysis and continued monitoring of the performance and efficiency of the maintenance programme, in order to correct any deficiency in that programme;
- j) a description of aircraft types and models to which the manual applies;
- k) a description of procedures for ensuring that unserviceabilities affecting airworthiness are recorded and rectified; and
- l) a description of the procedures for advising the State of Registry of significant in-service occurrences.

11.3 Maintenance programme

11.3.1 A maintenance programme for each aeroplane as required by 8.3 shall contain the following information:

- a) maintenance tasks and the intervals at which these are to be performed, taking into account the anticipated utilization of the aeroplane;
- b) when applicable, a continuing structural integrity programme;
- c) procedures for changing or deviating from a) and b) above; and
- d) when applicable, condition monitoring and reliability programme descriptions for aircraft systems, components and engines.

11.3.2 Maintenance tasks and intervals that have been specified as mandatory in approval of the type design shall be identified as such.

11.3.3 **Recommendation.**— *The maintenance programme should be based on maintenance programme information made available by the State of Design or by the organization responsible for the type design, and any additional applicable experience.*

11.4 Journey log book

11.4.1 **Recommendation.**— *The aeroplane journey log book should contain the following items and the corresponding roman numerals:*

- I — *Aeroplane nationality and registration.*
- II — *Date.*
- III — *Names of crew members.*

- IV — *Duty assignments of crew members.*
- V — *Place of departure.*
- VI — *Place of arrival.*
- VII — *Time of departure.*
- VIII — *Time of arrival.*
- IX — *Hours of flight.*
- X — *Nature of flight (private, aerial work, scheduled or non-scheduled).*
- XI — *Incidents, observations, if any.*
- XII — *Signature of person in charge.*

11.4.2 **Recommendation.**— *Entries in the journey log book should be made currently and in ink or indelible pencil.*

11.4.3 **Recommendation.**— *Completed journey log book should be retained to provide a continuous record of the last six months' operations.*

11.5 Records of emergency and survival equipment carried

Operators shall at all times have available for immediate communication to rescue coordination centres, lists containing information on the emergency and survival equipment carried on board any of their aeroplanes engaged in international air navigation. The information shall include, as applicable, the number, colour and type of life rafts and pyrotechnics, details of emergency medical supplies, water supplies and the type and frequencies of the emergency portable radio equipment.

11.6 Flight recorder records

An operator shall ensure, to the extent possible, in the event the aeroplane becomes involved in an accident or incident, the preservation of all related flight recorder records and, if necessary, the associated flight recorders, and their retention in safe custody pending their disposition as determined in accordance with Annex 13.

CHAPTER 12. CABIN CREW

12.1 Assignment of emergency duties

An operator shall establish, to the satisfaction of the State of the Operator, the minimum number of cabin crew required for each type of aeroplane, based on seating capacity or the number of passengers carried, in order to effect a safe and expeditious evacuation of the aeroplane, and the necessary functions to be performed in an emergency or a situation requiring emergency evacuation. The operator shall assign these functions for each type of aeroplane.

12.2 Cabin crew at emergency evacuation stations

Each cabin crew member assigned to emergency evacuation duties shall occupy a seat provided in accordance with 6.16 during take-off and landing and whenever the pilot-in-command so directs.

12.3 Protection of cabin crew during flight

Each cabin crew member shall be seated with seat belt or, when provided, safety harness fastened during take-off and landing and whenever the pilot-in-command so directs.

Note.— The foregoing does not preclude the pilot-in-command from directing the fastening of the seat belt only, at times other than during take-off and landing.

12.4 Training

An operator shall establish and maintain a training programme, approved by the State of the Operator, to be completed by all persons before being assigned as a cabin crew member. Cabin crew members shall complete a recurrent training programme annually. These training programmes shall ensure that each person is:

- a) competent to execute those safety duties and functions which the cabin crew member is assigned to perform in the event of an emergency or in a situation requiring emergency evacuation;
- b) drilled and capable in the use of emergency and life-saving equipment required to be carried, such as life jackets, life rafts, evacuation slides, emergency exits, portable fire extinguishers, oxygen equipment, first-aid and universal precaution kits, and automated external defibrillators;
- c) when serving on aeroplanes operated above 3 000 m (10 000 ft), knowledgeable as regards the effect of lack of oxygen and, in the case of pressurized aeroplanes, as regards physiological phenomena accompanying a loss of pressurization;
- d) aware of other crew members' assignments and functions in the event of an emergency so far as is necessary for the fulfilment of the cabin crew member's own duties;
- e) aware of the types of dangerous goods which may, and may not, be carried in a passenger cabin; and
- f) knowledgeable about human performance as related to passenger cabin safety duties including flight crew-cabin crew coordination.

Note 1.— Requirements for the training of cabin crew members in the transport of dangerous goods are included in the Dangerous Goods Training Programme contained in Annex 18 — The Safe Transport of Dangerous Goods by Air and the Technical Instructions for the Safe Transport of Dangerous Goods by Air (Doc 9284).

Note 2.— Guidance material to design training programmes to develop knowledge and skills in human performance can be found in the Human Factors Training Manual (Doc 9683).

CHAPTER 13. SECURITY*

13.1 Domestic commercial operations

Recommendation.— *International Standards and Recommended Practices set forth in this Chapter should be applied by all Contracting States also in case of domestic commercial operations (air services).*

13.2 Security of the flight crew compartment

13.2.1 In all aeroplanes which are equipped with a flight crew compartment door, this door shall be capable of being locked, and means shall be provided by which cabin crew can discreetly notify the flight crew in the event of suspicious activity or security breaches in the cabin.

13.2.2 From 1 November 2003, all passenger-carrying aeroplanes of a maximum certificated take-off mass in excess of 45 500 kg or with a passenger seating capacity greater than 60 shall be equipped with an approved flight crew compartment door that is designed to resist penetration by small arms fire and grenade shrapnel, and to resist forcible intrusions by unauthorized persons. This door shall be capable of being locked and unlocked from either pilot's station.

13.2.3 In all aeroplanes which are equipped with a flight crew compartment door in accordance with 13.2.2:

- a) this door shall be closed and locked from the time all external doors are closed following embarkation until any such door is opened for disembarkation, except when necessary to permit access and egress by authorized persons; and
- b) means shall be provided for monitoring from either pilot's station the entire door area outside the flight crew compartment to identify persons requesting entry and to detect suspicious behaviour or potential threat.

13.2.4 **Recommendation.**— *All passenger-carrying aeroplanes should be equipped with an approved flight crew compartment door, where practicable, that is designed to resist penetration by small arms fire and grenade shrapnel, and to resist forcible intrusions by unauthorized persons. This door should be capable of being locked and unlocked from either pilot's station.*

13.2.5 **Recommendation.**— *In all aeroplanes which are equipped with a flight crew compartment door in accordance with 13.2.4:*

- a) *the door should be closed and locked from the time all external doors are closed following embarkation until any such door is opened for disembarkation, except when necessary to permit access and egress by authorized persons; and*
- b) *means should be provided for monitoring from either pilot's station the entire door area outside the flight crew compartment to identify persons requesting entry and to detect suspicious behaviour or potential threat.*

* In the context of this Chapter, the word "security" is used in the sense of prevention of illicit acts against civil aviation.

13.3 Aeroplane search procedure checklist

An operator shall ensure that there is on board a checklist of the procedures to be followed in searching for a bomb in case of suspected sabotage and for inspecting aeroplanes for concealed weapons, explosives or other dangerous devices when a well-founded suspicion exists that the aeroplane may be the object of an act of unlawful interference. The checklist shall be supported by guidance on the appropriate course of action to be taken should a bomb or suspicious object be found and information on the least-risk bomb location specific to the aeroplane.

13.4 Training programmes

13.4.1 An operator shall establish and maintain an approved security training programme which ensures crew members act in the most appropriate manner to minimize the consequences of acts of unlawful interference. As a minimum, this programme shall include the following elements:

- a) determination of the seriousness of any occurrence;
- b) crew communication and coordination;
- c) appropriate self-defence responses;
- d) use of non-lethal protective devices assigned to crew members whose use is authorized by the State of the Operator;
- e) understanding of behaviour of terrorists so as to facilitate the ability of crew members to cope with hijacker behaviour and passenger responses;
- f) live situational training exercises regarding various threat conditions;
- g) flight crew compartment procedures to protect the aeroplane; and
- h) aeroplane search procedures and guidance on least-risk bomb locations where practicable.

13.4.2 An operator shall also establish and maintain a training programme to acquaint appropriate employees with preventive measures and techniques in relation to passengers, baggage, cargo, mail, equipment, stores and supplies intended for carriage on an aeroplane so that they contribute to the prevention of acts of sabotage or other forms of unlawful interference.

13.5 Reporting acts of unlawful interference

Following an act of unlawful interference, the pilot-in-command shall submit, without delay, a report of such an act to the designated local authority.

13.6 Miscellaneous

13.6.1 **Recommendation.**— *Specialized means of attenuating and directing the blast should be provided for use at the least-risk bomb location.*

13.6.2 **Recommendation.**— *Where an operator accepts the carriage of weapons removed from passengers, the aeroplane should have provision for stowing such weapons in a place so that they are inaccessible to any person during flight time.*

APPENDIX 1. LIGHTS TO BE DISPLAYED BY AEROPLANES

(Note.— See Chapter 6, 6.10)

1. Terminology

When the following terms are used in this Appendix, they have the following meanings:

Angles of coverage.

- a) Angle of coverage A is formed by two intersecting vertical planes making angles of 70 degrees to the right and 70 degrees to the left respectively, looking aft along the longitudinal axis to a vertical plane passing through the longitudinal axis.
- b) Angle of coverage F is formed by two intersecting vertical planes making angles of 110 degrees to the right and 110 degrees to the left respectively, looking forward along the longitudinal axis to a vertical plane passing through the longitudinal axis.
- c) Angle of coverage L is formed by two intersecting vertical planes, one parallel to the longitudinal axis of the aeroplane, and the other 110 degrees to the left of the first, when looking forward along the longitudinal axis.
- d) Angle of coverage R is formed by two intersecting vertical planes, one parallel to the longitudinal axis of the aeroplane, and the other 110 degrees to the right of the first, when looking forward along the longitudinal axis.

Horizontal plane. The plane containing the longitudinal axis and perpendicular to the plane of symmetry of the aeroplane.

Longitudinal axis of the aeroplane. A selected axis parallel to the direction of flight at a normal cruising speed, and passing through the centre of gravity of the aeroplane.

Making way. An aeroplane on the surface of the water is “making way” when it is under way and has a velocity relative to the water.

Under command. An aeroplane on the surface of the water is “under command” when it is able to execute manoeuvres as required by the International Regulations for Preventing Collisions at Sea for the purpose of avoiding other vessels.

Under way. An aeroplane on the surface of the water is “under way” when it is not aground or moored to the ground or to any fixed object on the land or in the water.

Vertical planes. Planes perpendicular to the horizontal plane.

Visible. Visible on a dark night with a clear atmosphere.

2. Navigation lights to be displayed in the air

Note.— The lights specified herein are intended to meet the requirements of Annex 2 for navigation lights.

As illustrated in Figure 1, the following unobstructed navigation lights shall be displayed:

- a) a red light projected above and below the horizontal plane through angle of coverage L;
- b) a green light projected above and below the horizontal plane through angle of coverage R;
- c) a white light projected above and below the horizontal plane rearward through angle of coverage A.

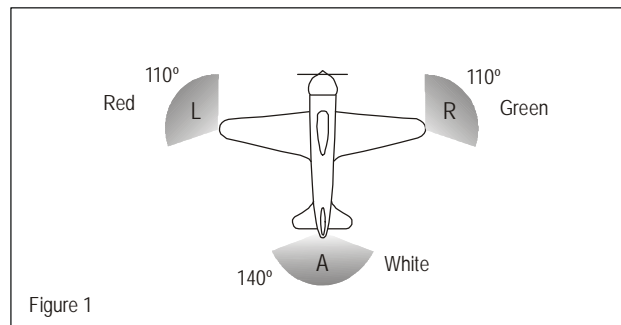

3. Lights to be displayed on the water

3.1 General

Note.— The lights specified herein are intended to meet the requirements of Annex 2 for lights to be displayed by aeroplanes on the water.

The International Regulations for Preventing Collisions at Sea require different lights to be displayed in each of the following circumstances:

- a) when under way;
- b) when towing another vessel or aeroplane;
- c) when being towed;
- d) when not under command and not making way;
- e) when making way but not under command;
- f) when at anchor;
- g) when aground.

The lights required by aeroplanes in each case are described below.

3.2 When under way

As illustrated in Figure 2, the following appearing as steady unobstructed lights:

- a) a red light projected above and below the horizontal through angle of coverage L;

- b) a green light projected above and below the horizontal through angle of coverage R;
- c) a white light projected above and below the horizontal through angle of coverage A; and
- d) a white light projected through angle of coverage F.

The lights described in 3.2 a), b) and c) should be visible at a distance of at least 3.7 km (2 NM). The light described in 3.2 d) should be visible at a distance of 9.3 km (5 NM) when fitted to an aeroplane of 20 m or more in length or visible at a distance of 5.6 km (3 NM) when fitted to an aeroplane of less than 20 m in length.

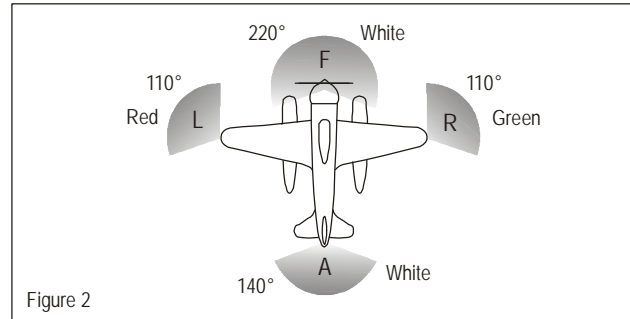

3.3 When towing another vessel or aeroplane

As illustrated in Figure 3, the following appearing as steady, unobstructed lights:

- a) the lights described in 3.2;
- b) a second light having the same characteristics as the light described in 3.2 d) and mounted in a vertical line at least 2 m above or below it; and
- c) a yellow light having otherwise the same characteristics as the light described in 3.2 c) and mounted in a vertical line at least 2 m above it.

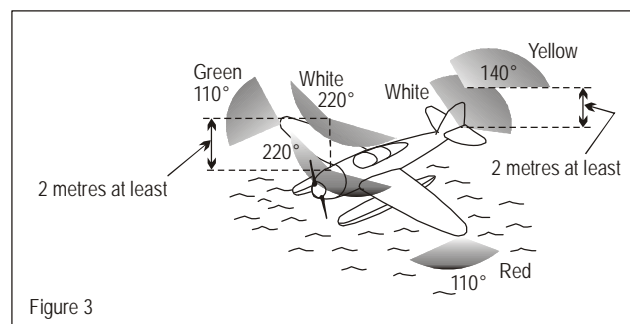

3.4 When being towed

The lights described in 3.2 a), b) and c) appearing as steady, unobstructed lights.

3.5 When not under command and not making way

As illustrated in Figure 4, two steady red lights placed where they can best be seen, one vertically over the other and not less than 1 m apart, and of such a character as to be visible all around the horizon at a distance of at least 3.7 km (2 NM).

3.6 When making way but not under command

As illustrated in Figure 5, the lights described in 3.5 plus the lights described in 3.2 a), b) and c).

Note.— The display of lights prescribed in 3.5 and 3.6 is to be taken by other aircraft as signals that the aeroplane showing them is not under command and cannot therefore get out of the way. They are not signals of aeroplanes in distress and requiring assistance.

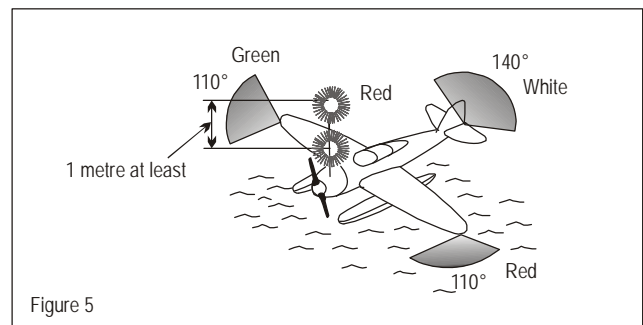
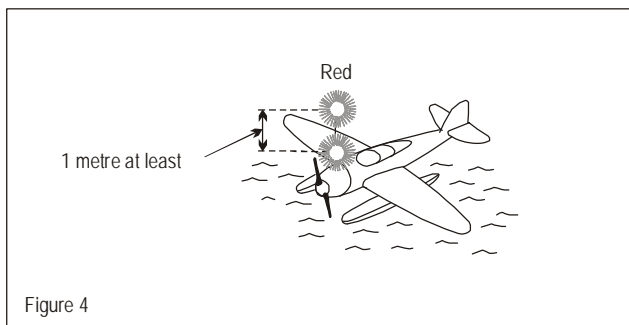

3.7 When at anchor

- a) If less than 50 m in length, where it can best be seen, a steady white light (Figure 6), visible all around the horizon at a distance of at least 3.7 km (2 NM).
- b) If 50 m or more in length, where they can best be seen, a steady white forward light and a steady white rear light (Figure 7) both visible all around the horizon at a distance of at least 5.6 km (3 NM).
- c) If 50 m or more in span a steady white light on each side (Figures 8 and 9) to indicate the maximum span and visible, so far as practicable, all around the horizon at a distance of at least 1.9 km (1 NM).

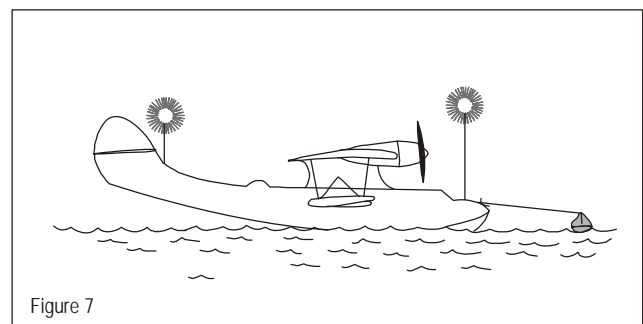
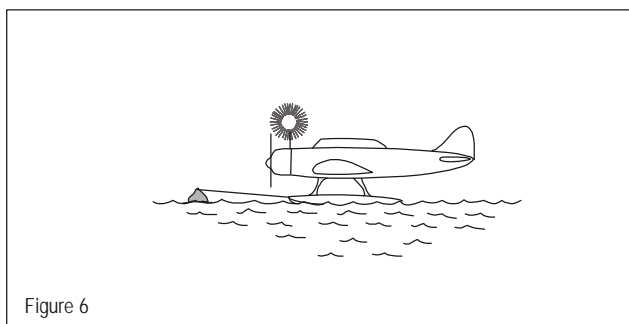

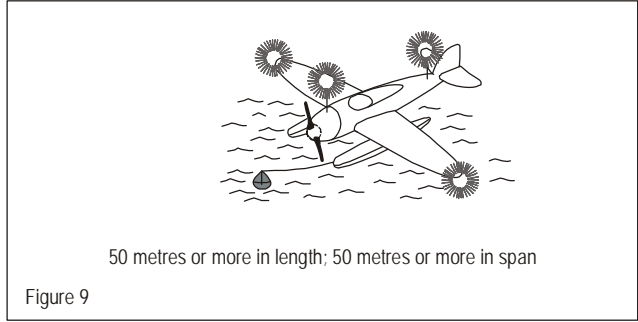
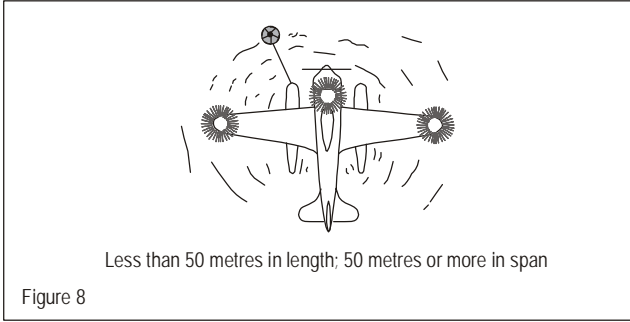

3.8 When aground

The lights prescribed in 3.7 and in addition two steady red lights in vertical line, at least 1 m apart so placed as to be visible all around the horizon.

APPENDIX 2. ORGANIZATION AND CONTENTS OF AN OPERATIONS MANUAL

(See Chapter 4, 4.2.3.1)

1. Organization

1.1 **Recommendation.**— *An operations manual, which may be issued in separate parts corresponding to specific aspects of operations, provided in accordance with Chapter 4, 4.2.3.1 should be organized with the following structure:*

- a) *General;*
- b) *Aircraft operating information;*
- c) *Areas, routes and aerodromes; and*
- d) *Training.*

1.2 From 1 January 2006, an operations manual, which may be issued in separate parts corresponding to specific aspects of operations, provided in accordance with Chapter 4, 4.2.3.1 shall be organized with the following structure:

- a) General;
- b) Aircraft operating information;
- c) Areas, routes and aerodromes; and
- d) Training.

2. Contents

The operations manual referred to in 1.1 and 1.2 shall contain at the least the following:

2.1 General

2.1.1 Instructions outlining the responsibilities of operations personnel pertaining to the conduct of flight operations.

2.1.2 Information and policy relating to fatigue management including:

- a) rules pertaining to flight time, flight duty period, duty period limitations and rest requirements for flight and cabin crew members in accordance with Chapter 4, 4.10.2 a); and
- b) policy and documentation pertaining to the operator's FRMS in accordance with Appendix 8.

2.1.3 A list of the navigational equipment to be carried including any requirements relating to operations where performance-based navigation is prescribed.

2.1.4 Where relevant to the operations, the long-range navigation procedures, engine failure procedure for EDTO and the nomination and utilization of diversion aerodromes.

- 2.1.5 The circumstances in which a radio listening watch is to be maintained.
 - 2.1.6 The method for determining minimum flight altitudes.
 - 2.1.7 The methods for determining aerodrome operating minima.
 - 2.1.8 Safety precautions during refuelling with passengers on board.
 - 2.1.9 Ground handling arrangements and procedures.
 - 2.1.10 Procedures, as prescribed in Annex 12, for pilots-in-command observing an accident.
 - 2.1.11 The flight crew for each type of operation including the designation of the succession of command.
 - 2.1.12 Specific instructions for the computation of the quantities of fuel and oil to be carried, taking into account all circumstances of the operation including the possibility of loss of pressurization and the failure of one or more engines while en route.
 - 2.1.13 The conditions under which oxygen shall be used and the amount of oxygen determined in accordance with Chapter 4, 4.3.9.2.
 - 2.1.14 Instructions for mass and balance control.
 - 2.1.15 Instructions for the conduct and control of ground de-icing/anti-icing operations.
 - 2.1.16 The specifications for the operational flight plan.
 - 2.1.17 Standard operating procedures (SOP) for each phase of flight.
 - 2.1.18 Instructions on the use of normal checklists and the timing of their use.
 - 2.1.19 Departure contingency procedures.
 - 2.1.20 Instructions on the maintenance of altitude awareness and the use of automated or flight crew altitude call-out.
 - 2.1.21 Instructions on the use of autopilots and auto-throttles in IMC.
- Note.— Instructions on the use of autopilots and auto-throttles, together with 2.1.26 and 2.1.30, are essential for avoidance of approach and landing accidents and controlled flight into terrain accidents.*
- 2.1.22 Instructions on the clarification and acceptance of ATC clearances, particularly where terrain clearance is involved.
 - 2.1.23 Departure and approach briefings.
 - 2.1.24 Procedures for familiarization with areas, routes and aerodromes.
 - 2.1.25 Stabilized approach procedure.
 - 2.1.26 Limitation on high rates of descent near the surface.
 - 2.1.27 Conditions required to commence or to continue an instrument approach.

2.1.28 Instructions for the conduct of precision and non-precision instrument approach procedures.

2.1.29 Allocation of flight crew duties and procedures for the management of crew workload during night and IMC instrument approach and landing operations.

2.1.30 Instructions and training requirements for the avoidance of controlled flight into terrain and policy for the use of the ground proximity warning system (GPWS).

2.1.31 Policy, instructions, procedures and training requirements for the avoidance of collisions and the use of the airborne collision avoidance system (ACAS).

Note.— Procedures for the operation of ACAS are contained in PANS-OPS (Doc 8168), Volume I, and in PANS-ATM (Doc 4444), Chapters 12 and 15.

2.1.32 Information and instructions relating to the interception of civil aircraft including:

- a) procedures, as prescribed in Annex 2, for pilots-in-command of intercepted aircraft; and
- b) visual signals for use by intercepting and intercepted aircraft, as contained in Annex 2.

2.1.33 For aeroplanes intended to be operated above 15 000 m (49 000 ft):

- a) information which will enable the pilot to determine the best course of action to take in the event of exposure to solar cosmic radiation; and
- b) procedures in the event that a decision to descend is taken, covering:
 - 1) the necessity of giving the appropriate ATS unit prior warning of the situation and of obtaining a provisional descent clearance; and
 - 2) the action to be taken in the event that communication with the ATS unit cannot be established or is interrupted.

Note.— Guidance material on the information to be provided is contained in Circular 126 — Guidance Material on SST Aircraft Operations.

2.1.34 Details of the safety management system (SMS) provided in accordance with Chapter 3, 3.3.3.

2.1.35 Information and instructions on the carriage of dangerous goods, including action to be taken in the event of an emergency.

Note.— Guidance material on the development of policies and procedures for dealing with dangerous goods incidents on board aircraft is contained in Emergency Response Guidance for Aircraft Incidents involving Dangerous Goods (Doc 9481).

2.1.36 Security instructions and guidance.

2.1.37 The search procedure checklist provided in accordance with Chapter 13, 13.3.

2.1.38 Instructions and training requirements for the use of head-up displays (HUD) and enhanced vision systems (EVS) equipment as applicable.

2.2 Aircraft operating information

2.2.1 Certification limitations and operating limitations.

2.2.2 The normal, abnormal and emergency procedures to be used by the flight crew and the checklists relating thereto as required by Chapter 6, 6.1.4.

2.2.3 Operating instructions and information on climb performance with all engines operating, if provided in accordance with Chapter 4, 4.2.4.3.

2.2.4 Flight planning data for pre-flight and in-flight planning with different thrust/power and speed settings.

2.2.5 The maximum crosswind and tailwind components for each aeroplane type operated and the reductions to be applied to these values having regard to gusts, low visibility, runway surface conditions, crew experience, use of autopilot, abnormal or emergency circumstances, or any other relevant operational factors.

2.2.6 Instructions and data for mass and balance calculations.

2.2.7 Instructions for aircraft loading and securing of load.

2.2.8 Aircraft systems, associated controls and instructions for their use, as required by Chapter 6, 6.1.4.

2.2.9 The minimum equipment list and configuration deviation list for the aeroplane types operated and specific operations authorized, including any requirements relating to operations where performance-based navigation is prescribed.

2.2.10 Checklist of emergency and safety equipment and instructions for its use.

2.2.11 Emergency evacuation procedures, including type-specific procedures, crew coordination, assignment of crew's emergency positions and the emergency duties assigned to each crew member.

2.2.12 The normal, abnormal and emergency procedures to be used by the cabin crew, the checklists relating thereto and aircraft systems information as required, including a statement related to the necessary procedures for the coordination between flight and cabin crew.

2.2.13 Survival and emergency equipment for different routes and the necessary procedures to verify its normal functioning before take-off, including procedures to determine the required amount of oxygen and the quantity available.

2.2.14 The ground-air visual signal code for use by survivors, as contained in Annex 12.

2.3 Routes and aerodromes

2.3.1 A route guide to ensure that the flight crew will have, for each flight, information relating to communication facilities, navigation aids, aerodromes, instrument approaches, instrument arrivals and instrument departures as applicable for the operation, and such other information as the operator may deem necessary for the proper conduct of flight operations.

2.3.2 The minimum flight altitudes for each route to be flown.

2.3.3 Aerodrome operating minima for each of the aerodromes that are likely to be used as aerodromes of intended landing or as alternate aerodromes.

2.3.4 The increase of aerodrome operating minima in case of degradation of approach or aerodrome facilities.

2.3.5 Instructions for determining aerodrome operating minima for instrument approaches using HUD and EVS.

2.3.6 The necessary information for compliance with all flight profiles required by regulations, including but not limited to, the determination of:

- a) take-off runway length requirements for dry, wet and contaminated conditions, including those dictated by system failures which affect the take-off distance;
- b) take-off climb limitations;
- c) en-route climb limitations;
- d) approach climb limitations and landing climb limitations;
- e) landing runway length requirements for dry, wet and contaminated conditions, including systems failures which affect the landing distance; and
- f) supplementary information, such as tire speed limitations.

2.4 Training

2.4.1 Details of the flight crew training programme, as required by Chapter 9, 9.3.

2.4.2 Details of the cabin crew duties training programme as required by Chapter 12, 12.4.

2.4.3 Details of the flight operations officer/flight dispatcher training programme when employed in conjunction with a method of flight supervision in accordance with Chapter 4, 4.2.1.

Note.— Details of the flight operations officer/flight dispatcher training programme are contained in Chapter 10, 10.2.

**APPENDIX 3. ADDITIONAL REQUIREMENTS FOR APPROVED
OPERATIONS BY SINGLE-ENGINE TURBINE-POWERED
AEROPLANES AT NIGHT AND/OR IN INSTRUMENT
METEOROLOGICAL CONDITIONS (IMC)**

(See Chapter 5, 5.4.1)

Airworthiness and operational requirements provided in accordance with Chapter 5, 5.4.1, shall satisfy the following:

1. Turbine engine reliability

1.1 Turbine engine reliability shall be shown to have a power loss rate of less than 1 per 100 000 engine hours.

Note.— Power loss in this context is defined as any loss of power, the cause of which may be traced to faulty engine or engine component design or installation, including design or installation of the fuel ancillary or engine control systems. (See Attachment H.)

1.2 The operator shall be responsible for engine trend monitoring.

1.3 To minimize the probability of in-flight engine failure, the engine shall be equipped with:

- a) an ignition system that activates automatically, or is capable of being operated manually, for take-off and landing, and during flight, in visible moisture;
- b) a magnetic particle detection or equivalent system that monitors the engine, accessories gearbox, and reduction gearbox, and which includes a flight deck caution indication; and
- c) an emergency engine power control device that permits continuing operation of the engine through a sufficient power range to safely complete the flight in the event of any reasonably probable failure of the fuel control unit.

2. Systems and equipment

Single-engine turbine-powered aeroplanes approved to operate at night and/or in IMC shall be equipped with the following systems and equipment intended to ensure continued safe flight and to assist in achieving a safe forced landing after an engine failure, under all allowable operating conditions:

- a) two separate electrical generating systems, each one capable of supplying all probable combinations of continuous in-flight electrical loads for instruments, equipment and systems required at night and/or in IMC;
- b) a radio altimeter;
- c) an emergency electrical supply system of sufficient capacity and endurance, following loss of all generated power, to as a minimum:

- 1) maintain the operation of all essential flight instruments, communication and navigation systems during a descent from the maximum certificated altitude in a glide configuration to the completion of a landing;
 - 2) lower the flaps and landing gear, if applicable;
 - 3) provide power to one pitot heater, which must serve an air speed indicator clearly visible to the pilot;
 - 4) provide for operation of the landing light specified in 2 j);
 - 5) provide for one engine restart, if applicable; and
 - 6) provide for the operation of the radio altimeter;
- d) two attitude indicators, powered from independent sources;
 - e) a means to provide for at least one attempt at engine re-start;
 - f) airborne weather radar;
 - g) a certified area navigation system capable of being programmed with the positions of aerodromes and safe forced landing areas, and providing instantly available track and distance information to those locations;
 - h) for passenger operations, passenger seats and mounts which meet dynamically-tested performance standards and which are fitted with a shoulder harness or a safety belt with a diagonal shoulder strap for each passenger seat;
 - i) in pressurized aeroplanes, sufficient supplemental oxygen for all occupants for descent following engine failure at the maximum glide performance from the maximum certificated altitude to an altitude at which supplemental oxygen is no longer required;
 - j) a landing light that is independent of the landing gear and is capable of adequately illuminating the touchdown area in a night forced landing; and
 - k) an engine fire warning system.

3. Minimum equipment list

The State of the Operator shall require the minimum equipment list of an operator approved in accordance with Chapter 5, 5.4 to specify the operating equipment required for night and/or IMC operations, and for day/VMC operations.

4. Flight manual information

The flight manual shall include limitations, procedures, approval status and other information relevant to operations by single-engine turbine-powered aeroplanes at night and/or in IMC.

5. Event reporting

5.1 An operator approved for operations by single-engine turbine-powered aeroplanes at night and/or in IMC shall report all significant failures, malfunctions or defects to the State of the Operator who in turn will notify the State of Design.

5.2 The State of the Operator shall review the safety data and monitor the reliability information so as to be able to take any actions necessary to ensure that the intended safety level is achieved. The State of the Operator will notify major events or trends of particular concern to the appropriate Type Certificate Holder and the State of Design.

6. Operator planning

6.1 Operator route planning shall take account of all relevant information in the assessment of intended routes or areas of operations, including the following:

- a) the nature of the terrain to be overflown, including the potential for carrying out a safe forced landing in the event of an engine failure or major malfunction;
- b) weather information, including seasonal and other adverse meteorological influences that may affect the flight; and
- c) other criteria and limitations as specified by the State of the Operator.

6.2 An operator shall identify aerodromes or safe forced landing areas available for use in the event of engine failure, and the position of these shall be programmed into the area navigation system.

Note 1.— A ‘safe’ forced landing in this context means a landing in an area at which it can reasonably be expected that it will not lead to serious injury or loss of life, even though the aeroplane may incur extensive damage.

Note 2.— Operation over routes and in weather conditions that permit a safe forced landing in the event of an engine failure, as specified in Chapter 5, 5.1.2, is not required by Appendix 3, 6.1 and 6.2 for aeroplanes approved in accordance with Chapter 5, 5.4. The availability of forced landing areas at all points along a route is not specified for these aeroplanes because of the very high engine reliability, additional systems and operational equipment, procedures and training requirements specified in this Appendix.

7. Flight crew experience, training and checking

7.1 The State of the Operator shall prescribe the minimum flight crew experience required for night/IMC operations by single-engine turbine-powered aeroplanes.

7.2 An operator’s flight crew training and checking shall be appropriate to night and/or IMC operations by single-engine turbine-powered aeroplanes, covering normal, abnormal and emergency procedures and, in particular, engine failure, including descent to a forced landing in night and/or in IMC conditions.

8. Route limitations over water

The State of the Operator shall apply route limitation criteria for single-engine turbine-powered aeroplanes operating at night and/or in IMC on over water operations if beyond gliding distance from an area suitable for a safe forced landing/ditching having regard to the characteristics of the aeroplane, seasonal weather influences, including likely sea state and temperature, and the availability of search and rescue services.

9. Operator certification or validation

The operator shall demonstrate the ability to conduct operations by single-engine turbine-powered aeroplanes at night and/or in IMC through a certification and approval process specified by the State of the Operator.

Note.— Guidance on the airworthiness and operational requirements is contained in Attachment H.

APPENDIX 4. ALTIMETRY SYSTEM PERFORMANCE REQUIREMENTS FOR OPERATIONS IN RVSM AIRSPACE

(Note.— See Chapter 7, 7.2.5)

1. In respect of groups of aeroplanes that are nominally of identical design and build with respect to all details that could influence the accuracy of height-keeping performance, the height-keeping performance capability shall be such that the total vertical error (TVE) for the group of aeroplanes shall have a mean no greater than 25 m (80 ft) in magnitude and shall have a standard deviation no greater than $28 - 0.013z^2$ for $0 \leq z \leq 25$ when z is the magnitude of the mean TVE in metres, or $92 - 0.004z^2$ for $0 \leq z \leq 80$ where z is in feet. In addition, the components of TVE shall have the following characteristics:

- a) the mean altimetry system error (ASE) of the group shall not exceed 25 m (80 ft) in magnitude;
- b) the sum of the absolute value of the mean ASE and of three standard deviations of ASE shall not exceed 75 m (245 ft);
and
- c) the differences between cleared flight level and the indicated pressure altitude actually flown shall be symmetric about a mean of 0 m, with a standard deviation no greater than 13.3 m (43.7 ft), and in addition, the decrease in the frequency of differences with increasing difference magnitude shall be at least exponential.

2. In respect of aeroplanes for which the characteristics of the airframe and altimetry system fit are unique and so cannot be classified as belonging to a group of aeroplanes encompassed by paragraph 1, the height-keeping performance capability shall be such that the components of the TVE of the aeroplane have the following characteristics:

- a) the ASE of the aeroplane shall not exceed 60 m (200 ft) in magnitude under all flight conditions; and
- b) the differences between the cleared flight level and the indicated pressure altitude actually flown shall be symmetric about a mean of 0 m, with a standard deviation no greater than 13.3 m (43.7 ft), and in addition, the decrease in the frequency of differences with increasing difference magnitude shall be at least exponential.

APPENDIX 5. SAFETY OVERSIGHT OF AIR OPERATORS

(Note.— See Chapter 4, 4.2.1.8)

1. Primary aviation legislation

1.1 The State of the Operator shall enact and implement laws that enable the State to regulate civil aviation through a Civil Aviation Authority (CAA) or equivalent organization established for that purpose. The legislation shall empower the authority to discharge the oversight responsibilities of the State. The legislation shall provide for the making of regulations, the certification and continued supervision of air operators, and the resolution of safety issues identified by the authority.

Note.— The term authority as used in this Appendix refers to the Civil Aviation Authority as well as equivalent organizations, including inspectors and staff.

1.2 The State of the Operator shall ensure that the laws of the State require air operators to provide the authority with access to their personnel, aircraft, operations and facilities and associated records for the purpose of certification and continued surveillance.

Note.— Guidance on the critical elements of a system that enables a State to discharge its responsibility for inspection, certification and continued surveillance of operations is contained in the Safety Oversight Manual (Doc 9734), Part A — The Establishment and Management of a State's Safety Oversight System, the Manual of Procedures for Operations Inspection, Certification and Continued Surveillance (Doc 8335) and the Airworthiness Manual (Doc 9760).

2. Specific operating regulations

2.1 The State of the Operator shall adopt regulations that provide for the certification and continued surveillance of aircraft operations and the maintenance of aircraft in conformity with the Annexes to the Convention on International Civil Aviation.

2.2 The State of the Operator shall ensure that its regulations are sufficiently comprehensive, detailed and current with respect to changes in technology and the operating environment to ensure that satisfactory compliance will result in an acceptable level of safety for the operations undertaken.

3. CAA structure and safety oversight functions

3.1 The State of the Operator shall ensure that the authority is responsible for the safety oversight of air operators and that it has resources appropriate to the size and complexity of civil air operations under the jurisdiction of the State, to effectively discharge the responsibilities of the State.

3.2 The State of the Operator shall ensure that authority inspectors have adequate support, credentials and transportation to accomplish, independently, their certification and continued surveillance tasks.

4. Technical guidance

4.1 The State of the Operator shall ensure that authority inspectors are provided with technical guidance manuals containing the policies, procedures and standards to be used in the certification and continued surveillance of air operators.

4.2 The State of the Operator shall ensure that authority inspectors are provided with technical guidance manuals containing the policies, procedures and standards to be used in the resolution of safety issues, including enforcement.

4.3 The State of the Operator shall ensure that authority inspectors are provided with technical guidance manuals that address ethics, personal conduct and the avoidance of actual or perceived conflicts of interest in the performance of official duties.

5. Qualified technical personnel

5.1 The State of the Operator shall use a methodology to determine its inspector staffing requirements according to the size and complexity of civil air operations in that State.

5.2 **Recommendation.**— *The methodology in 5.1 should be documented.*

5.3 The State of the Operator shall establish qualification requirements to ensure that its inspector personnel have operational or technical work experience and training compatible with those activities they are required to certificate or inspect.

Note.— *Guidance on experience and training for inspectors is contained in the Manual of Procedures for Operations Inspection, Certification and Continued Surveillance (Doc 8335).*

5.4 The State of the Operator shall require authority inspectors to complete initial and recurrent training in relevant technical subjects (including aircraft-specific subjects) and in skills necessary to effectively accomplish their certification and continued surveillance tasks.

5.5 **Recommendation.**— *The State of the Operator should take the necessary measures, such as remuneration and conditions of service, to ensure that qualified inspectors are recruited and retained.*

6. Licensing and certification obligations

6.1 The State of the Operator shall use a documented process for the certification of air operators that includes thorough technical evaluations that lead to approval or acceptance of procedures, documents and operations as specified in Annex 6, Part I.

6.2 The State of the Operator shall require, prior to commencement of new commercial air transport operations, air operators to demonstrate that they can safely conduct the proposed operations.

Note.— *Attachment E contains further information in this regard.*

7. Continued surveillance obligations

7.1 The State of the Operator shall use a documented process for the continued surveillance of air operators to verify the continued validity of the air operator certificates issued by the authority.

7.2 The State of the Operator shall use an ongoing surveillance plan to confirm that operators continue to meet the relevant requirements for initial certification and that each air operator is functioning satisfactorily.

8. Resolution of safety issues

8.1 The State of the Operator shall use a documented process to take appropriate corrective actions, up to and including enforcement measures, to resolve identified safety issues.

8.2 The State of the Operator shall ensure that identified safety issues are resolved in a timely manner through a system which monitors and records progress, including actions taken by the air operator, in resolving such issues.

APPENDIX 6. AIR OPERATOR CERTIFICATE (AOC)

(Note. — See Chapter 4, 4.2.1.5 and 4.2.1.6)

1. Purpose and scope

1.1 The AOC and its associated model specific operations specifications shall contain the minimum information required in paragraphs 2 and 3 respectively, in a standardized format.

1.2 The air operator certificate and its associated operations specifications shall define the operations for which an operator is authorized.

Note.— Attachment E, paragraph 3.2.2, contains additional information that may be listed in the operations specifications associated with the air operator certificate.

2. AOC template

Note.— Chapter 6, 6.1.2, requires a certified true copy of the AOC to be carried aboard.

AIR OPERATOR CERTIFICATE		
1	STATE OF THE OPERATOR²	1
	ISSUING AUTHORITY³	
AOC # ⁴ : Expiry date ⁵ :	OPERATOR NAME⁶ Dba trading name ⁷ : Operator address ⁸ : Telephone ⁹ : Fax: E-mail:	OPERATIONAL POINTS OF CONTACT¹⁰ Contact details, at which operational management can be contacted without undue delay, are listed in _____ ¹¹ .
This certificate certifies that _____ ¹² is authorized to perform commercial air operations, as defined in the attached operations specifications, in accordance with the operations manual and the _____ ¹³ .		
Date of issue ¹⁴ :	Name and signature ¹⁵ : Title:	

Notes.—

1. *For use of the State of the Operator.*
2. *Replace by the name of the State of the Operator.*
3. *Replace by the identification of the issuing authority of the State of the Operator.*
4. *Unique AOC number, as issued by the State of the Operator.*
5. *Date after which the AOC ceases to be valid (dd-mm-yyyy).*
6. *Replace by the operator's registered name.*
7. *Operator's trading name, if different. Insert "dba" before the trading name (for "doing business as").*
8. *Operator's principal place of business address.*
9. *Operator's principal place of business telephone and fax details, including the country code. E-mail to be provided if available.*

10. The contact details include the telephone and fax numbers, including the country code, and the e-mail address (if available) at which operational management can be contacted without undue delay for issues related to flight operations, airworthiness, flight and cabin crew competency, dangerous goods and other matters, as appropriate.
11. Insert the controlled document, carried on board, in which the contact details are listed, with the appropriate paragraph or page reference, e.g.: “Contact details are listed in the operations manual, Gen/Basic, Chapter 1, 1.1” or “... are listed in the operations specifications, page 1” or “... are listed in an attachment to this document”.
12. Operator’s registered name.
13. Insertion of reference to the appropriate civil aviation regulations.
14. Issuance date of the AOC (dd-mm-yyyy).
15. Title, name and signature of the authority representative. In addition, an official stamp may be applied on the AOC.

3. Operations specifications for each aircraft model

Note.— Chapter 6, 6.1.2, requires a copy of the operations specifications of this section to be carried aboard.

3.1 For each aircraft model in the operator’s fleet, identified by aircraft make, model and series, the following list of authorizations, conditions and limitations shall be included: issuing authority contact details, operator name and AOC number, date of issue and signature of the authority representative, aircraft model, types and area of operations, special limitations and authorizations.

Note.— If authorizations and limitations are identical for two or more models, these models may be grouped in a single list.

3.2 The operations specifications layout referred to in Chapter 4, 4.2.1.6, shall be as follows:

Note.— The MEL constitutes an integral part of the operations manual.

OPERATIONS SPECIFICATIONS (subject to the approved conditions in the operations manual)				
ISSUING AUTHORITY CONTACT DETAILS¹				
Telephone: _____		Fax: _____		E-mail: _____
AOC# ² : _____		Operator name ³ : _____		Date ⁴ : _____ Signature: _____
Dba trading name: _____				
Aircraft model ⁵ : _____				
Types of operation: Commercial air transportation <input type="checkbox"/> Passengers <input type="checkbox"/> Cargo <input type="checkbox"/> Other ⁶ : _____				
Area(s) of operation ⁷ : _____				
Special limitations ⁸ : _____				
SPECIAL AUTHORIZATIONS	YES	NO	SPECIFIC APPROVALS ⁹	REMARKS
Dangerous goods	<input type="checkbox"/>	<input type="checkbox"/>		
Low visibility operations				
Approach and landing	<input type="checkbox"/>	<input type="checkbox"/>	CAT ¹⁰ : _____ RVR: _____ m DH: _____ ft	
Take-off	<input type="checkbox"/>	<input type="checkbox"/>	RVR ¹¹ : _____ m	
RVSM ¹² <input type="checkbox"/> N/A	<input type="checkbox"/>	<input type="checkbox"/>		
EDTO ¹³ <input type="checkbox"/> N/A	<input type="checkbox"/>	<input type="checkbox"/>	Threshold time ¹⁴ : _____ minutes	
	<input type="checkbox"/>	<input type="checkbox"/>	Maximum diversion time ¹⁴ : _____ minutes	
Navigation specifications for PBN operations ¹⁵	<input type="checkbox"/>	<input type="checkbox"/>		¹⁶
Continuing airworthiness	<input checked="" type="checkbox"/>	<input checked="" type="checkbox"/>	¹⁷	
Other ¹⁸	<input type="checkbox"/>	<input type="checkbox"/>		

Notes.—

1. Telephone and fax contact details of the authority, including the country code. E-mail to be provided if available.
2. Insert the associated AOC number.
3. Insert the operator's registered name and the operator's trading name, if different. Insert "dba" before the trading name (for "doing business as").

4. Issuance date of the operations specifications (dd-mm-yyyy) and signature of the authority representative.
 5. Insert the Commercial Aviation Safety Team (CAST)/ICAO designation of the aircraft make, model and series, or master series, if a series has been designated (e.g. Boeing-737-3K2 or Boeing-777-232). The CAST/ICAO taxonomy is available at: <http://www.intlaviationstandards.org/>.
 6. Other type of transportation to be specified (e.g. emergency medical service).
 7. List the geographical area(s) of authorized operation (by geographical coordinates or specific routes, flight information region or national or regional boundaries).
 8. List the applicable special limitations (e.g. VFR only, day only).
 9. List in this column the most permissive criteria for each approval or the approval type (with appropriate criteria).
 10. Insert the applicable precision approach category (CAT I, II, IIIA, IIIB or IIIC). Insert the minimum RVR in metres and decision height in feet. One line is used per listed approach category.
 11. Insert the approved minimum take-off RVR in metres. One line per approval may be used if different approvals are granted.
 12. "Not applicable (N/A)" box may be checked only if the aircraft maximum ceiling is below FL 290.
 13. If extended diversion time operations (EDTO) approval does not apply based on the provisions in Chapter 4, 4.7, select "N/A". Otherwise a threshold time and maximum diversion time must be specified.
 14. The threshold time and maximum diversion time may also be listed in distance (NM), as well as the engine type.
 15. Performance-based navigation (PBN): one line is used for each PBN specification authorization (e.g. RNAV 10, RNAV 1, RNP 4), with appropriate limitations or conditions listed in the "Specific Approvals" and/or "Remarks" columns.
 16. Limitations, conditions and regulatory basis for operational approval associated with the performance-based navigation specifications (e.g. GNSS, DME/DME/IRU). Information on performance-based navigation, and guidance concerning the implementation and operational approval process, are contained in the Performance-based Navigation (PBN) Manual (Doc 9613).
 17. Insert the name of the person/organization responsible for ensuring that the continuing airworthiness of the aircraft is maintained and the regulation that requires the work, i.e. within the AOC regulation or a specific approval (e.g. EC2042/2003, Part M, Subpart G).
 18. Other authorizations or data can be entered here, using one line (or one multi-line block) per authorization (e.g. special approach authorization, MNPS, approved navigation performance).
-

APPENDIX 7. FRAMEWORK FOR SAFETY MANAGEMENT SYSTEMS (SMS)

(See Chapter 3, 3.3.4, and Chapter 8, 8.7.3.4)

This appendix specifies the framework for the implementation and maintenance of a safety management system (SMS) by an operator or an approved maintenance organization. An SMS is a management system for the management of safety by an organization. The framework includes four components and twelve elements representing the minimum requirements for SMS implementation. The implementation of the framework shall be commensurate with the size of the organization and the complexity of the services provided. This appendix also includes a brief description of each element of the framework.

1. Safety policy and objectives
 - 1.1 Management commitment and responsibility
 - 1.2 Safety accountabilities
 - 1.3 Appointment of key safety personnel
 - 1.4 Coordination of emergency response planning
 - 1.5 SMS documentation
2. Safety risk management
 - 2.1 Hazard identification
 - 2.2 Safety risk assessment and mitigation
3. Safety assurance
 - 3.1 Safety performance monitoring and measurement
 - 3.2 The management of change
 - 3.3 Continuous improvement of the SMS
4. Safety promotion
 - 4.1 Training and education
 - 4.2 Safety communication

1. Safety policy and objectives

1.1 Management commitment and responsibility

The operator/approved maintenance organization shall define the organization's safety policy which shall be in accordance with international and national requirements, and which shall be signed by the accountable executive of the organization. The safety policy shall reflect organizational commitments regarding safety; shall include a clear statement about the provision of the necessary resources for the implementation of the safety policy; and shall be communicated, with visible endorsement, throughout the organization. The safety policy shall include the safety reporting procedures; shall clearly indicate which types

of operational behaviours are unacceptable; and shall include the conditions under which disciplinary action would not apply. The safety policy shall be periodically reviewed to ensure it remains relevant and appropriate to the organization.

1.2 Safety accountabilities

The operator/approved maintenance organization shall identify the accountable executive who, irrespective of other functions, shall have ultimate responsibility and accountability, on behalf of the operator/approved maintenance organization, for the implementation and maintenance of the SMS. The operator/approved maintenance organization shall also identify the accountabilities of all members of management, irrespective of other functions, as well as of employees, with respect to the safety performance of the SMS. Safety responsibilities, accountabilities and authorities shall be documented and communicated throughout the organization, and shall include a definition of the levels of management with authority to make decisions regarding safety risk tolerability.

1.3 Appointment of key safety personnel

The operator/approved maintenance organization shall identify a safety manager to be the responsible individual and focal point for the implementation and maintenance of an effective SMS.

1.4 Coordination of emergency response planning

The operator/approved maintenance organization shall ensure that an emergency response plan that provides for the orderly and efficient transition from normal to emergency operations and the return to normal operations is properly coordinated with the emergency response plans of those organizations it must interface with during the provision of its services.

1.5 SMS documentation

The operator/approved maintenance organization shall develop an SMS implementation plan, endorsed by senior management of the organization, that defines the organization's approach to the management of safety in a manner that meets the organization's safety objectives. The organization shall develop and maintain SMS documentation describing the safety policy and objectives, the SMS requirements, the SMS processes and procedures, the accountabilities, responsibilities and authorities for processes and procedures, and the SMS outputs. Also as part of the SMS documentation, the operator/approved maintenance organization shall develop and maintain a safety management systems manual (SMSM), to communicate its approach to the management of safety throughout the organization.

2. Safety risk management

2.1 Hazard identification

The operator/approved maintenance organization shall develop and maintain a formal process that ensures that hazards in operations are identified. Hazard identification shall be based on a combination of reactive, proactive and predictive methods of safety data collection.

2.2 Safety risk assessment and mitigation

The operator/approved maintenance organization shall develop and maintain a formal process that ensures analysis, assessment and control of the safety risks in flight/maintenance operations.

3. Safety assurance

3.1 Safety performance monitoring and measurement

The operator/approved maintenance organization shall develop and maintain the means to verify the safety performance of the organization and to validate the effectiveness of safety risk controls. The safety performance of the organization shall be verified in reference to the safety performance indicators and safety performance targets of the SMS.

3.2 The management of change

The operator/approved maintenance organization shall develop and maintain a formal process to identify changes within the organization which may affect established processes and services; to describe the arrangements to ensure safety performance before implementing changes; and to eliminate or modify safety risk controls that are no longer needed or effective due to changes in the operational environment.

3.3 Continuous improvement of the SMS

The operator/approved maintenance organization shall develop and maintain a formal process to identify the causes of substandard performance of the SMS, determine the implications of substandard performance of the SMS in operations, and eliminate or mitigate such causes.

4. Safety promotion

4.1 Training and education

The operator/approved maintenance organization shall develop and maintain a safety training programme that ensures that personnel are trained and competent to perform the SMS duties. The scope of the safety training shall be appropriate to each individual's involvement in the SMS.

4.2 Safety communication

The operator/approved maintenance organization shall develop and maintain formal means for safety communication that ensures that all personnel are fully aware of the SMS, conveys safety-critical information, and explains why particular safety actions are taken and why safety procedures are introduced or changed.

APPENDIX 8. FATIGUE RISK MANAGEMENT SYSTEM REQUIREMENTS

Note.— Guidance on the development, implementation, approval and monitoring of an FRMS is contained in the Fatigue Risk Management Systems Manual for Regulators (Doc 9966).

A Fatigue Risk Management System (FRMS) established in accordance with Chapter 4, 4.10.6, shall contain, at a minimum:

1. FRMS POLICY AND DOCUMENTATION

1.1 FRMS policy

1.1.1 The operator shall define its FRMS policy, with all elements of the FRMS clearly identified.

1.1.2 The policy shall require that the scope of FRMS operations be clearly defined in the operations manual.

1.1.3 The policy shall:

- a) reflect the shared responsibility of management, flight and cabin crews, and other involved personnel;
- b) clearly state the safety objectives of the FRMS;
- c) be signed by the accountable executive of the organization;
- d) be communicated, with visible endorsement, to all the relevant areas and levels of the organization;
- e) declare management commitment to effective safety reporting;
- f) declare management commitment to the provision of adequate resources for the FRMS;
- g) declare management commitment to continuous improvement of the FRMS;
- h) require that clear lines of accountability for management, flight and cabin crews, and all other involved personnel are identified; and
- i) require periodic reviews to ensure it remains relevant and appropriate.

Note.— Effective safety reporting is described in the Safety Management Manual (SMM) (Doc 9859).

1.2 FRMS documentation

An operator shall develop and keep current FRMS documentation that describes and records:

- a) FRMS policy and objectives;
- b) FRMS processes and procedures;
- c) accountabilities, responsibilities and authorities for these processes and procedures;
- d) mechanisms for ongoing involvement of management, flight and cabin crew members, and all other involved personnel;
- e) FRMS training programmes, training requirements and attendance records;
- f) scheduled and actual flight times, duty periods and rest periods with significant deviations and reasons for deviations noted; and

Note.— Significant deviations are described in the Fatigue Risk Management Systems Manual for Regulators (Doc 9966).

- g) FRMS outputs including findings from collected data, recommendations, and actions taken.

2. FATIGUE RISK MANAGEMENT PROCESSES

2.1 Identification of hazards

Note.— Legal guidance for the protection of information from safety data collection and processing systems is contained in Annex 13, Attachment E.

An operator shall develop and maintain three fundamental and documented processes for fatigue hazard identification:

2.1.1 Predictive

The predictive process shall identify fatigue hazards by examining crew scheduling and taking into account factors known to affect sleep and fatigue and their effects on performance. Methods of examination may include but are not limited to:

- a) operator or industry operational experience and data collected on similar types of operations;
- b) evidence-based scheduling practices; and
- c) bio-mathematical models.

2.1.2 Proactive

The proactive process shall identify fatigue hazards within current flight operations. Methods of examination may include but are not limited to:

- a) self-reporting of fatigue risks;
- b) crew fatigue surveys;
- c) relevant flight and cabin crew performance data;
- d) available safety databases and scientific studies; and
- e) analysis of planned versus actual time worked.

2.1.3 Reactive

The reactive process shall identify the contribution of fatigue hazards to reports and events associated with potential negative safety consequences in order to determine how the impact of fatigue could have been minimized. At a minimum, the process may be triggered by any of the following:

- a) fatigue reports;
- b) confidential reports;
- c) audit reports;
- d) incidents; and
- e) flight data analysis events.

2.2 Risk assessment

2.2.1 An operator shall develop and implement risk assessment procedures that determine the probability and potential severity of fatigue-related events and identify when the associated risks require mitigation.

2.2.2 The risk assessment procedures shall review identified hazards and link them to:

- a) operational processes;
- b) their probability;
- c) possible consequences; and
- d) the effectiveness of existing safety barriers and controls.

2.3 Risk mitigation

An operator shall develop and implement risk mitigation procedures that:

- a) select the appropriate mitigation strategies;
- b) implement the mitigation strategies; and
- c) monitor the strategies' implementation and effectiveness.

3. FRMS SAFETY ASSURANCE PROCESSES

The operator shall develop and maintain FRMS safety assurance processes to:

- a) provide for continuous FRMS performance monitoring, analysis of trends, and measurement to validate the effectiveness of the fatigue safety risk controls. The sources of data may include, but are not limited to:
 - 1) hazard reporting and investigations;

- 2) audits and surveys; and
 - 3) reviews and fatigue studies;
- b) provide a formal process for the management of change which shall include but is not limited to:
- 1) identification of changes in the operational environment that may affect FRMS;
 - 2) identification of changes within the organization that may affect FRMS; and
 - 3) consideration of available tools which could be used to maintain or improve FRMS performance prior to implementing changes; and
- c) provide for the continuous improvement of the FRMS. This shall include but is not limited to:
- 1) the elimination and/or modification of risk controls that have had unintended consequences or that are no longer needed due to changes in the operational or organizational environment;
 - 2) routine evaluations of facilities, equipment, documentation and procedures; and
 - 3) the determination of the need to introduce new processes and procedures to mitigate emerging fatigue-related risks.

4. FRMS PROMOTION PROCESSES

FRMS promotion processes support the ongoing development of the FRMS, the continuous improvement of its overall performance, and attainment of optimum safety levels. The following shall be established and implemented by the operator as part of its FRMS:

- a) training programmes to ensure competency commensurate with the roles and responsibilities of management, flight and cabin crew, and all other involved personnel under the planned FRMS; and
- b) an effective FRMS communication plan that:
 - 1) explains FRMS policies, procedures and responsibilities to all relevant stakeholders; and
 - 2) describes communication channels used to gather and disseminate FRMS-related information.

APPENDIX 9. FLIGHT RECORDERS

(Note. — See Chapter 6, 6.3)

The material in this Appendix concerns flight recorders intended for installation in aeroplanes engaged in international air navigation. Crash protected flight recorders comprise one or more of the following systems: a flight data recorder (FDR), a cockpit voice recorder (CVR), an airborne image recorder (AIR) and/or a data link recorder (DLR). Lightweight flight recorders comprise one or more of the following systems: an aircraft data recording system (ADRS), a cockpit audio recording system (CARS), an airborne image recording system (AIRS) and/or a data link recording system (DLRS).

1. General requirements

1.1 The flight recorder containers shall:

- a) be painted a distinctive orange or yellow colour;
- b) carry reflective material to facilitate their location; and
- c) have securely attached an automatically activated underwater locating device operating at a frequency of 37.5 kHz. At the earliest practicable date, but not later than 1 January 2018, this device shall operate for a minimum of 90 days.

1.2 The flight recorder systems shall be installed so that:

- a) the probability of damage to the recordings is minimized;
- b) they receive electrical power from a bus that provides the maximum reliability for operation of the flight recorder systems without jeopardizing service to essential or emergency loads;
- c) there is an aural or visual means for pre-flight checking that the flight recorder systems are operating properly; and
- d) if the flight recorder systems have a bulk erasure device, the installation shall be designed to prevent operation of the device during flight time or crash impact.

1.3 The flight recorder systems, when tested by methods approved by the appropriate certificating authority, shall be demonstrated to be suitable for the environmental extremes over which they are designed to operate.

1.4 Means shall be provided for an accurate time correlation between the flight recorder systems recordings.

1.5 The manufacturer shall provide the appropriate certificating authority with the following information in respect of the flight recording systems:

- a) manufacturer's operating instructions, equipment limitations and installation procedures;
- b) parameter origin or source and equations which relate counts to units of measurement; and
- c) manufacturer's test reports.

2. Flight Data Recorder (FDR)

2.1 The flight data recorder shall start to record prior to the aeroplane moving under its own power and record continuously until the termination of the flight when the aeroplane is no longer capable of moving under its own power.

2.2 Parameters to be recorded

2.2.1 Flight data recorders shall be classified as Type I, Type IA, Type II and Type IIA depending upon the number of parameters to be recorded and the duration required for retention of the recorded information.

2.2.2 The parameters that satisfy the requirements for FDRs are listed in the paragraphs below. The number of parameters to be recorded shall depend on aeroplane complexity. The parameters without an asterisk (*) are mandatory parameters which shall be recorded regardless of aeroplane complexity. In addition, the parameters designated by an asterisk (*) shall be recorded if an information data source for the parameter is used by aeroplane systems or the flight crew to operate the aeroplane. However, other parameters may be substituted with due regard to the aeroplane type and the characteristics of the recording equipment.

2.2.2.1 The following parameters shall satisfy the requirements for flight path and speed:

- Pressure altitude
- Indicated airspeed or calibrated airspeed
- Air-ground status and each landing gear air-ground sensor when practicable
- Total or outside air temperature
- Heading (primary flight crew reference)
- Normal acceleration
- Lateral acceleration
- Longitudinal acceleration (body axis)
- Time or relative time count
- Navigation data*: drift angle, wind speed, wind direction, latitude/longitude
- Groundspeed*
- Radio altitude*

2.2.2.2 The following parameters shall satisfy the requirements for attitude:

- Pitch attitude
- Roll attitude
- Yaw or sideslip angle*
- Angle of attack*

2.2.2.3 The following parameters shall satisfy the requirements for engine power:

- Engine thrust/power: propulsive thrust/power on each engine, cockpit thrust/power lever position
- Thrust reverse status*
- Engine thrust command*
- Engine thrust target*
- Engine bleed valve position*
- Additional engine parameters*: EPR, N_1 , indicated vibration level, N_2 , EGT, TLA, fuel flow, fuel cut-off lever position, N_3

2.2.2.4 The following parameters shall satisfy the requirements for configuration:

- Pitch trim surface position
- Flaps*: trailing edge flap position, cockpit control selection
- Slats*: leading edge flap (slat) position, cockpit control selection
- Landing gear*: landing gear, gear selector position
- Yaw trim surface position*
- Roll trim surface position*
- Cockpit trim control input position pitch*
- Cockpit trim control input position roll*
- Cockpit trim control input position yaw*
- Ground spoiler and speed brake*: Ground spoiler position, ground spoiler selection, speed brake position, speed brake selection
- De-icing and/or anti-icing systems selection*
- Hydraulic pressure (each system)*
- Fuel quantity in CG trim tank *
- AC electrical bus status*
- DC electrical bus status*
- APU bleed valve position*
- Computed centre of gravity*

2.2.2.5 The following parameters shall satisfy the requirements for operation:

- Warnings
- Primary flight control surface and primary flight control pilot input: pitch axis, roll axis, yaw axis
- Marker beacon passage
- Each navigation receiver frequency selection
- Manual radio transmission keying and CVR/FDR synchronization reference
- Autopilot/autothrottle/AFCS mode and engagement status*
- Selected barometric setting*: pilot, first officer
- Selected altitude (all pilot selectable modes of operation)*
- Selected speed (all pilot selectable modes of operation)*
- Selected Mach (all pilot selectable modes of operation)*
- Selected vertical speed (all pilot selectable modes of operation)*
- Selected heading (all pilot selectable modes of operation)*
- Selected flight path (all pilot selectable modes of operation)*: course/DSTRK, path angle
- Selected decision height*
- EFIS display format*: pilot, first officer
- Multi-function/engine/alerts display format*
- GPWS/TAWS/GCAS status*: selection of terrain display mode including pop-up display status, terrain alerts, both cautions and warnings, and advisories, on/off switch position
- Low pressure warning*: hydraulic pressure, pneumatic pressure
- Computer failure*
- Loss of cabin pressure*
- TCAS/ACAS (traffic alert and collision avoidance system/airborne collision avoidance system)*
- Ice detection*
- Engine warning each engine vibration*
- Engine warning each engine over temperature*
- Engine warning each engine oil pressure low*
- Engine warning each engine over speed*
- Wind shear warning*
- Operational stall protection, stick shaker and pusher activation*
- All cockpit flight control input forces*: control wheel, control column, rudder pedal cockpit input forces

- Vertical deviation*: ILS glide path, MLS elevation, GNSS approach path
- Horizontal deviation*: ILS localizer, MLS azimuth, GNSS approach path
- DME 1 and 2 distances*
- Primary navigation system reference*: GNSS, INS, VOR/DME, MLS, Loran C, ILS
- Brakes*: left and right brake pressure, left and right brake pedal position
- Date*
- Event marker*
- Head up display in use*
- Para visual display on*

Note 1.— Parameter guidance for range, sampling, accuracy and resolution are as contained in the EUROCAE ED-112, Minimum Operational Performance Specification (MOPS) for Crash Protected Airborne Recorder Systems, or equivalent documents.

Note 2.— It is not intended that aeroplanes issued with an individual certificate of airworthiness before 1 January 2016 be modified to meet the range, sampling, accuracy or resolution guidance detailed in this Appendix.

2.2.2.6 *Type IA FDR.* This FDR shall be capable of recording, as appropriate to the aeroplane, at least the 78 parameters in Table A9-1.

2.2.2.7 *Type I FDR.* This FDR shall be capable of recording, as appropriate to the aeroplane, at least the first 32 parameters in Table A9-1.

2.2.2.8 *Types II and IIA FDRs.* These FDRs shall be capable of recording, as appropriate to the aeroplane, at least the first 16 parameters in Table A9-1.

2.2.2.9 The parameters that satisfy the requirements for flight path and speed as displayed to the pilot(s) are listed below. The parameters without an (*) are mandatory parameters which shall be recorded. In addition, the parameters designated by an (*) shall be recorded if an information source for the parameter is displayed to the pilot and is practicable to record:

- Pressure altitude
- Indicated airspeed or calibrated airspeed
- Heading (primary flight crew reference)
- Pitch attitude
- Roll attitude
- Engine thrust/power
- Landing-gear status*
- Total or outside air temperature*
- Time*
- Navigation data*: drift angle, wind speed, wind direction, latitude/longitude
- Radio altitude*

2.3 Additional information

2.3.1 A Type IIA FDR, in addition to a 30-minute recording duration, shall retain sufficient information from the preceding take-off for calibration purposes.

2.3.2 The measurement range, recording interval and accuracy of parameters on installed equipment shall be verified by methods approved by the appropriate certificating authority.

2.3.3 Documentation concerning parameter allocation, conversion equations, periodic calibration and other serviceability/maintenance information shall be maintained by the operator. The documentation needs to be sufficient to ensure that accident investigation authorities have the necessary information to read out the data in engineering units.

3. Cockpit Voice Recorder (CVR) and Cockpit Audio Recording System (CARS)

3.1 Signals to be recorded

The CVR and CARS shall start to record prior to the aeroplane moving under its own power and record continuously until the termination of the flight when the aeroplane is no longer capable of moving under its own power. In addition, depending on the availability of electrical power, the CVR and CARS shall start to record as early as possible during the cockpit checks prior to engine start at the beginning of the flight until the cockpit checks immediately following engine shutdown at the end of the flight.

3.1.1 The CVR shall record on four separate channels, or more, at least the following:

- a) voice communication transmitted from or received in the aeroplane by radio;
- b) aural environment on the flight deck;
- c) voice communication of flight crew members on the flight deck using the aeroplane's interphone system, if installed;
- d) voice or audio signals identifying navigation or approach aids introduced in the headset or speaker; and
- e) voice communication of flight crew members using the passenger address system, if installed

3.1.2 The CARS shall record on two separate channels, or more, at least the following:

- a) voice communication transmitted from or received in the aeroplane by radio;
- b) aural environment on the flight deck; and
- c) voice communication of flight crew members on the flight deck using the aeroplane's interphone system, if installed.

3.1.3 The CVR shall be capable of recording on at least four channels simultaneously. On a tape-based CVR, to ensure accurate time correlation between channels, the CVR is to record in an in-line format. If a bi-directional configuration is used, the in-line format and channel allocation shall be retained in both directions.

3.1.4 The preferred channel allocation shall be as follows:

Channel 1 — co-pilot headphones and live boom microphone

Channel 2 — pilot headphones and live boom microphone

Channel 3 — area microphone

Channel 4 — time reference plus the third and fourth crew members' headphone and live microphone, if applicable.

Note 1.— Channel 1 is located closest to the base of the recording head.

Note 2.— The preferred channel allocation presumes use of current conventional magnetic tape transport mechanisms, and is specified because the outer edges of the tape have a higher risk of damage than the middle. It is not intended to preclude use of alternative recording media where such constraints may not apply.

4. Airborne image recorder (AIR)

4.1 Classes

4.1.1 A Class A AIR captures the general cockpit area in order to provide data supplemental to conventional flight recorders.

Note 1.— To respect crew privacy, the cockpit area view may be designed as far as practical to exclude the head and shoulders of crew members whilst seated in their normal operating position.

Note 2.— There are no provisions for Class A AIRs in this document.

4.1.2 A Class B AIR captures data link message displays.

4.1.3 A Class C AIR captures instruments and control panels.

Note.— A Class C AIR may be considered as a means for recording flight data where it is not practical or is prohibitively expensive to record on an FDR, or where an FDR is not required.

4.2 Operation

The AIR must start to record prior to the aeroplane moving under its own power and record continuously until the termination of the flight when the aeroplane is no longer capable of moving under its own power. In addition, depending on the availability of electrical power, the AIR must start to record as early as possible during the cockpit checks prior to engine start at the beginning of the flight until the cockpit checks immediately following engine shutdown at the end of the flight.

5. Data link recorder (DLR)

5.1 Applications to be recorded

5.1.1 Where the aircraft flight path is authorized or controlled through the use of data link messages, all data link messages, both uplinks (to the aircraft) and downlinks (from the aircraft), shall be recorded on the aircraft. As far as practicable, the time the messages were displayed to the flight crew and the time of the responses shall be recorded.

Note.— Sufficient information to derive the content of the data link communications message and the time the messages were displayed to the flight crew is needed to determine an accurate sequence of events on board the aircraft.

5.1.2 Messages applying to the applications listed below shall be recorded. Applications without the asterisk (*) are mandatory applications which shall be recorded regardless of the system complexity. Applications with an (*) shall be recorded only as far as is practicable given the architecture of the system.

- Data link initiation capability
- Controller–pilot data link communications
- Data link – flight information services
- Automatic dependent surveillance – contract
- Automatic dependent surveillance – broadcast*
- Aeronautical operational control*.

Note.— Descriptions of the applications are contained in Table A9-2.

6. Aircraft data recording systems (ADRS)

6.1 Parameters to be recorded

ADRS shall be capable of recording, as appropriate to the aeroplane, at least the essential (E) parameters in Table A9-3.

6.2 Additional information

6.2.1 The measurement range, recording interval and accuracy of parameters on installed equipment is usually verified by methods approved by the appropriate certificating authority.

6.2.2 Documentation concerning parameter allocation, conversion equations, periodic calibration and other serviceability/maintenance information shall be maintained by the operator. The documentation needs to be sufficient to ensure that accident investigation authorities have the necessary information to read out the data in engineering units.

7. Inspections of flight recorder systems

7.1 Prior to the first flight of the day, the built-in test features for the flight recorders and flight data acquisition unit (FDAU), when installed, shall be monitored by manual and/or automatic checks.

7.2 Annual inspections shall be carried out as follows:

- a) an analysis of the recorded data from the flight recorders shall ensure that the recorder operates correctly for the nominal duration of the recording;
- b) the analysis of the FDR shall evaluate the quality of the recorded data to determine if the bit error rate (including those errors introduced by recorder, the acquisition unit, the source of the data on the aeroplane and by the tools used to extract the data from the recorder) is within acceptable limits and to determine the nature and distribution of the errors;
- c) a complete flight from the FDR shall be examined in engineering units to evaluate the validity of all recorded parameters. Particular attention shall be given to parameters from sensors dedicated to the FDR. Parameters taken from the aircraft's electrical bus system need not be checked if their serviceability can be detected by other aircraft systems;
- d) the readout facility shall have the necessary software to accurately convert the recorded values to engineering units and to determine the status of discrete signals;

- e) an annual examination of the recorded signal on the CVR shall be carried out by replay of the CVR recording. While installed in the aircraft, the CVR shall record test signals from each aircraft source and from relevant external sources to ensure that all required signals meet intelligibility standards;
- f) where practicable, during the annual examination, a sample of in-flight recordings of the CVR shall be examined for evidence that the intelligibility of the signal is acceptable; and
- g) an annual examination of the recorded images on the AIR shall be carried out by replay of the AIR recording. While installed in the aircraft, the AIR shall record test images from each aircraft source and from relevant external sources to ensure that all required images meet recording quality standards.

7.3 Flight recorder systems shall be considered unserviceable if there is a significant period of poor quality data, unintelligible signals, or if one or more of the mandatory parameters is not recorded correctly.

7.4 A report of the annual inspection shall be made available on request to regulatory authorities for monitoring purposes.

7.5 Calibration of the FDR system:

- a) for those parameters which have sensors dedicated only to the FDR and are not checked by other means, recalibration shall be carried out at least every five years or in accordance with the recommendations of the sensor manufacturer to determine any discrepancies in the engineering conversion routines for the mandatory parameters and to ensure that parameters are being recorded within the calibration tolerances; and
- b) when the parameters of altitude and airspeed are provided by sensors that are dedicated to the FDR system, there shall be a recalibration performed as recommended by the sensor manufacturer, or at least every two years.

Table A9-1. Parameter Guidance for Crash Protected Flight Data Recorders

Serial number	Parameter	Measurement range	Maximum sampling and recording interval (seconds)	Accuracy limits (sensor input compared to FDR read-out)	Recording resolution
1	Time (UTC when available, otherwise relative time count or GPS time sync)	24 hours	4	±0.125% per hour	1 second
2	Pressure-altitude	−300 m (−1 000 ft) to maximum certificated altitude of aircraft +1 500 m (+5 000 ft)	1	±30 m to ±200 m (±100 ft to ±700 ft)	1.5 m (5 ft)
3	Indicated airspeed or calibrated airspeed	95 km/h (50 kt) to max V_{So} (Note 1) V_{So} to 1.2 V_D (Note 2)	1	±5% ±3%	1 kt (0.5 kt recommended)
4	Heading (primary flight crew reference)	360°	1	±2°	0.5°
5	Normal acceleration (Note 3)	−3 g to +6 g	0.125	±1% of maximum range excluding datum error of ±5%	0.004 g
6	Pitch attitude	±75° or usable range whichever is greater	0.25	±2°	0.5°
7	Roll attitude	±180°	0.25	±2°	0.5°
8	Radio transmission keying	On-off (one discrete)	1		
9	Power on each engine (Note 4)	Full range	1 (per engine)	±2%	0.2% of full range or the resolution required to operate the aircraft
10*	Trailing edge flap and cockpit control selection	Full range or each discrete position	2	±5% or as pilot's indicator	0.5% of full range or the resolution required to operate the aircraft
11*	Leading edge flap and cockpit control selection	Full range or each discrete position	2	±5% or as pilot's indicator	0.5% of full range or the resolution required to operate the aircraft
12*	Thrust reverser position	Stowed, in transit, and reverse	1 (per engine)		
13*	Ground spoiler/speed brake selection (selection and position)	Full range or each discrete position	1	±2% unless higher accuracy uniquely required	0.2% of full range
14	Outside air temperature	Sensor range	2	±2°C	0.3°C
15*	Autopilot/auto throttle/AFCS mode and engagement status	A suitable combination of discretes	1		
16	Longitudinal acceleration (Note 3)	±1 g	0.25	±0.015 g excluding a datum error of ±0.05 g	0.004 g
<i>Note.— The preceding 16 parameters satisfy the requirements for a Type II FDR.</i>					
17	Lateral acceleration (Note 3)	±1 g	0.25	±0.015 g excluding a datum error of ±0.05 g	0.004 g

Serial number	Parameter	Measurement range	Maximum sampling and recording interval (seconds)	Accuracy limits (sensor input compared to FDR read-out)	Recording resolution
18	Pilot input and/or control surface position—primary controls (pitch, roll, yaw) (Note 5) (Note 6)	Full range	0.25	±2° unless higher accuracy uniquely required	0.2% of full range or as installed
19	Pitch trim position	Full range	1	±3% unless higher accuracy uniquely required	0.3% of full range or as installed
20*	Radio altitude	–6 m to 750 m (–20 ft to 2 500 ft)	1	±0.6 m (±2 ft) or ±3% whichever is greater below 150 m (500 ft) and ±5% above 150 m (500 ft)	0.3 m (1 ft) below 150 m (500 ft) 0.3 m (1 ft) + 0.5% of full range above 150 m (500 ft)
21*	Vertical beam deviation (ILS/GPS/GLS glide path, MLS elevation, IRNAV/IAN vertical deviation)	Signal range	1	±3%	0.3% of full range
22*	Horizontal beam deviation (ILS/GPS/GLS localizer, MLS azimuth, IRNAV/IAN lateral deviation)	Signal range	1	±3%	0.3% of full range
23	Marker beacon passage	Discrete	1		
24	Master warning	Discrete	1		
25	Each NAV receiver frequency selection (Note 7)	Full range	4	As installed	
26*	DME 1 and 2 distance (includes Distance to runway threshold (GLS) and Distance to missed approach point (IRNAV/IAN)) (Notes 7 and 8)	0 – 370 km (0 – 200 NM)	4	As installed	1 852 m (1 NM)
27	Air/ground status	Discrete	1		
28*	GPWS/TAWS/GCAS status (selection of terrain display mode including pop-up display status) and (terrain alerts, both cautions and warnings, and advisories) and (on/off switch position)	Discrete	1		
29*	Angle of attack	Full range	0.5	As installed	0.3 % of full range
30*	Hydraulics, each system (low pressure)	Discrete	2		0.5% of full range
31*	Navigation data (latitude/longitude, ground speed and drift angle) (Note 9)	As installed	1	As installed	
32*	Landing gear and gear selector position	Discrete	4	As installed	

Note.— The preceding 32 parameters satisfy the requirements for a Type I FDR.

Serial number	Parameter	Measurement range	Maximum sampling and recording interval (seconds)	Accuracy limits (sensor input compared to FDR read-out)	Recording resolution
33*	Groundspeed	As installed	1	Data should be obtained from the most accurate system	1 kt
34	Brakes (left and right brake pressure, left and right brake pedal position)	(Maximum metered brake range, discrettes or full range)	1	±5%	2% of full range
35*	Additional engine parameters (EPR, N ₁ , indicated vibration level, N ₂ , EGT, fuel flow, fuel cut-off lever position, N ₃)	As installed	Each engine each second	As installed	2% of full range
36*	TCAS/ACAS (traffic alert and collision avoidance system)	Discrettes	1	As installed	
37*	Windshear warning	Discrete	1	As installed	
38*	Selected barometric setting (pilot, co-pilot)	As installed	64	As installed	0.1 mb (0.01 in-Hg)
39*	Selected altitude (all pilot selectable modes of operation)	As installed	1	As installed	Sufficient to determine crew selection
40*	Selected speed (all pilot selectable modes of operation)	As installed	1	As installed	Sufficient to determine crew selection
41*	Selected Mach (all pilot selectable modes of operation)	As installed	1	As installed	Sufficient to determine crew selection
42*	Selected vertical speed (all pilot selectable modes of operation)	As installed	1	As installed	Sufficient to determine crew selection
43*	Selected heading (all pilot selectable modes of operation)	As installed	1	As installed	Sufficient to determine crew selection
44*	Selected flight path (all pilot selectable modes of operation) (course/DSTRK, path angle, final approach path (IRNAV/IAN))		1	As installed	
45*	Selected Decision Height	As installed	64	As installed	Sufficient to determine crew selection
46*	EFIS display format (pilot, co-pilot)	Discrete(s)	4	As installed	
47*	Multi-function/engine/alerts display format	Discrete(s)	4	As installed	
48*	AC electrical bus status	Discrete(s)	4	As installed	
49*	DC electrical bus status	Discrete(s)	4	As installed	
50*	Engine bleed valve position	Discrete(s)	4	As installed	
51*	APU bleed valve position	Discrete(s)	4	As installed	
52*	Computer failure	Discrete(s)	4	As installed	
53*	Engine thrust command	As installed	2	As installed	
54*	Engine thrust target	As installed	4	As installed	2% of full range
55*	Computed centre of gravity	As installed	64	As installed	1% of full range

Serial number	Parameter	Measurement range	Maximum sampling and recording interval (seconds)	Accuracy limits (sensor input compared to FDR read-out)	Recording resolution
56*	Fuel quantity in CG trim tank	As installed	64	As installed	1% of full range
57*	Head up display in use	As installed	4	As installed	
58*	Para visual display on/off	As installed	1	As installed	
59*	Operational stall protection, stick shaker and pusher activation	As installed	1	As installed	
60*	Primary navigation system reference (GNSS, INS, VOR/DME, MLS, Loran C, localizer glideslope)	As installed	4	As installed	
61*	Ice detection	As installed	4	As installed	
62*	Engine warning each engine vibration	As installed	1	As installed	
63*	Engine warning each engine over temperature	As installed	1	As installed	
64*	Engine warning each engine oil pressure low	As installed	1	As installed	
65*	Engine warning each engine over speed	As installed	1	As installed	
66*	Yaw Trim Surface Position	Full range	2	±3% unless higher accuracy uniquely required	0.3% of full range
67*	Roll Trim Surface Position	Full range	2	±3% unless higher accuracy uniquely required	0.3% of full range
68*	Yaw or sideslip angle	Full range	1	±5%	0.5°
69*	De-icing and/or anti-icing systems selection	Discrete(s)	4		
70*	Hydraulic pressure (each system)	Full range	2	±5%	100 psi
71*	Loss of cabin pressure	Discrete	1		
72*	Cockpit trim control input position, Pitch	Full range	1	±5%	0.2% of full range or as installed
73*	Cockpit trim control input position, Roll	Full range	1	±5%	0.2% of full range or as installed
74*	Cockpit trim control input position, Yaw	Full range	1	±5%	0.2% of full range or as installed
75*	All cockpit flight control input forces (control wheel, control column, rudder pedal)	Full range (±311 N (±70 lbf), ± 378 N (±85 lbf), ± 734 N (±165 lbf))	1	±5%	0.2% of full range or as installed
76*	Event marker	Discrete	1		
77*	Date	365 days	64		
78*	ANP or EPE or EPU	As installed	4	As installed	

Note.— The preceding 78 parameters satisfy the requirements for a Type IA FDR.

Notes.—

1. V_{S0} stalling speed or minimum steady flight speed in the landing configuration is in Section “Abbreviations and Symbols”.
2. V_D design diving speed.
3. Refer to 6.3.1.2.11 for increased recording requirements.
4. Record sufficient inputs to determine power.
5. For aeroplanes with control systems in which movement of a control surface will back drive the pilot’s control, “or” applies. For aeroplanes with control systems in which movement of a control surface will not back drive the pilot’s control, “and” applies. In aeroplanes with split surfaces, a suitable combination of inputs is acceptable in lieu of recording each surface separately.
6. Refer to 6.3.1.2.12 for increased recording requirements.
7. If signal available in digital form.
8. Recording of latitude and longitude from INS or other navigation system is a preferred alternative.
9. If signals readily available.

If further recording capacity is available, recording of the following additional information should be considered:

- a) operational information from electronic display systems, such as electronic flight instrument systems (EFIS), electronic centralized aircraft monitor (ECAM) and engine indication and crew alerting system (EICAS). Use the following order of priority:
 - 1) parameters selected by the flight crew relating to the desired flight path, e.g. barometric pressure setting, selected altitude, selected airspeed, decision height, and autoflight system engagement and mode indications if not recorded from another source;
 - 2) display system selection/status, e.g. SECTOR, PLAN, ROSE, NAV, WXR, COMPOSITE, COPY, ETC.;
 - 3) warnings and alerts;
 - 4) the identity of displayed pages for emergency procedures and checklists; and
- b) retardation information including brake application for use in the investigation of landing overruns and rejected take-offs.

Table A9-2. Description of Applications for Data Link Recorders

Item No.	Application type	Application description	Recording content
1	Data link Initiation	This includes any applications used to logon to or initiate data link service. In FANS-1/A and ATN, these are ATS Facilities Notification (AFN) and Context Management (CM) respectively.	C
2	Controller/Pilot Communication	This includes any application used to exchange requests, clearances, instructions and reports between the flight crew and controllers on the ground. In FANS-1/A and ATN, this includes the CPDLC application. It also includes applications used for the exchange of oceanic (OCL) and departure clearances (DCL) as well as data link delivery of taxi clearances.	C
3	Addressed Surveillance	This includes any surveillance application in which the ground sets up contracts for delivery of surveillance data. In FANS-1/A and ATN, this includes the Automatic Dependent Surveillance (ADS-C) application. Where parametric data are reported within the message they shall be recorded unless data from the same source are recorded on the FDR.	C
4	Flight Information	This includes any service used for delivery of flight information to specific aircraft. This includes, for example, D-METAR, D-ATIS, D-NOTAM and other textual data link services.	C
5	Aircraft Broadcast Surveillance	This includes Elementary and Enhanced Surveillance Systems, as well as ADS-B output data. Where parametric data sent by the aeroplane are reported within the message they shall be recorded unless data from the same source are recorded on the FDR.	M *
6	Aeronautical Operational Control Data	This includes any application transmitting or receiving data used for AOC purposes (per the ICAO definition of AOC).	M *

Key:

C: Complete contents recorded.

M: Information that enables correlation to any associated records stored separately from the aeroplane.

*: Applications to be recorded only as far as is practicable given the architecture of the system.

Table A9-3. Parameter Guidance for Aircraft Data Recording Systems

No.	Parameter name	Parameter category	Minimum recording range	Maximum recording interval in seconds	Minimum recording accuracy	Minimum recording resolution	Remarks
1	Heading (Magnetic or True)	R*	±180 degrees	1	±2 degrees	0.5 degree	* If not available, record rates
2	Pitch attitude	E*	±90 degrees	0.25	±2 degrees	0.5 degree	* If not available, record rates
3	Roll attitude	E*	±180 degrees	0.25	±2 degrees	0.5 degree	* If not available, record rates
4	Yaw rate	E*	±300 degrees/s	0.25	±1% + drift of 360°/hr	2 degree/s	* Essential if no heading available
5	Pitch rate	E*	±300 degrees/s	0.25	±1% + drift of 360°/hr	2 degree/s	* Essential if no pitch attitude available
6	Roll rate	E*	±300 degrees/s	0.25	±1% + drift of 360°/hr	2 degree/s	* Essential if no roll attitude available
7	Positioning system : latitude/longitude	E	Latitude:±90 degrees Longitude:±180 degrees	2 (1 if available)	As installed (0.00015 degree recommended)	0.00005 degree	
8	Positioning system estimated error	E*	Available range	2 (1 if available)	As installed	As installed	* If available
9	Positioning system : altitude	E	-300 m (-1 000 ft) to maximum certificated altitude of aeroplane +1 500 m (5 000 ft)	2 (1 if available)	As installed (±15 m (±50 ft) recommended)	1.5 m (5 ft)	
10	Positioning system : time*	E	24 hours	1	±0.5 second	0.1 second	* UTC time preferred where available.
11	Positioning system : ground speed	E	0-1 000 kt	2 (1 if available)	As installed (±5 kt recommended)	1 kt	
12	Positioning system : channel	E	0-360 degrees	2 (1 if available)	As installed (± 2 degrees recommended)	0.5 degrees	
13	Normal acceleration	E	-3 g to + 6 g (*)	0.25 (0.125 if available)	As installed (± 0.09 g excluding a datum error of ±0.45 g recommended)	0.004 g	
14	Longitudinal acceleration	E	±1 g (*)	0.25 (0.125 if available)	As installed (±0.015 g excluding a datum error of ±0.05 g recommended)	0.004 g	
15	Lateral acceleration	E	±1 g (*)	0.25 (0.125 if available)	As installed (±0.015 g excluding a datum error of ±0.05 g recommended)	0.004 g	

No.	Parameter name	Parameter category	Minimum recording range	Maximum recording interval in seconds	Minimum recording accuracy	Minimum recording resolution	Remarks
16	External static pressure (or pressure altitude)	R	34.4 mb (3.44 in-Hg) to 310.2 mb (31.02 in-Hg) or available sensor range	1	As installed (± 1 mb (0.1 in-Hg) or ± 30 m (± 100 ft) to ± 210 m (± 700 ft) recommended)	0.1 mb (0.01 in-Hg) or 1.5 m (5 ft)	
17	Outside air temperature (or total air temperature)	R	-50° to $+90^{\circ}\text{C}$ or available sensor range	2	As installed ($\pm 2^{\circ}\text{C}$ recommended)	1°C	
18	Indicated air speed	R	As the installed pilot display measuring system or available sensor range	1	As installed ($\pm 3\%$ recommended)	1 kt (0.5 kt recommended)	
19	Engine RPM	R	Full range including overspeed condition	Each engine each second	As installed	0.2% of full range	
20	Engine oil pressure	R	Full range	Each engine each second	As installed (5% of full range recommended)	2% of full range	
21	Engine oil temperature	R	Full range	Each engine each second	As installed (5% of full range recommended)	2% of full range	
22	Fuel flow or pressure	R	Full range	Each engine each second	As installed	2% of full range	
23	Manifold pressure	R	Full range	Each engine each second	As installed	0.2% of full range	
24	Engine thrust/power/torque parameters required to determine propulsive thrust/power*	R	Full range	Each engine each second	As installed	0.1% of full range	* Sufficient parameters e.g. EPR/N1 or torque/Np as appropriate to the particular engine shall be recorded to determine power in both normal and reverse thrust. A margin for possible overspeed should be provided.
25	Engine gas generator speed (Ng)	R	0-150%	Each engine each second	As installed	0.2% of full range	
26	Free power turbine speed (Nf)	R	0-150%	Each engine each second	As installed	0.2% of full range	
27	Coolant temperature	R	Full range	1	As installed ($\pm 5^{\circ}\text{C}$ recommended)	1 degree Celsius	
28	Main voltage	R	Full range	Each engine each second	As installed	1 Volt	
29	Cylinder head temperature	R	Full range	Each cylinder each second	As installed	2% of full range	
30	Flaps position	R	Full range or each discrete position	2	As installed	0.5 degree	

No.	Parameter name	Parameter category	Minimum recording range	Maximum recording interval in seconds	Minimum recording accuracy	Minimum recording resolution	Remarks
31	Primary flight control surface position	R	Full range	0.25	As installed	0.2 % of full range	
32	Fuel quantity	R	Full range	4	As installed	1% of full range	
33	Exhaust gas temperature	R	Full range	Each engine each second	As installed	2% of full range	
34	Emergency voltage	R	Full range	Each engine each second	As installed	1 Volt	
35	Trim surface position	R	Full range or each discrete position	1	As installed	0.3% of full range	
36	Landing gear position	R	Each discrete position*	Each gear every two seconds	As installed		* Where available, record up-and-locked and down-and-locked position
37	Novel/unique aircraft features	R	As required	As required	As required	As required	

Key:

E: Essential parameters

R: Recommended parameters

ATTACHMENT A. GUIDANCE MATERIAL FOR DEVELOPMENT OF PRESCRIPTIVE FATIGUE MANAGEMENT REGULATIONS

Supplementary to Chapter 4, 4.10.1 and 4.10.2 a)

1. Purpose and scope

1.1 Flight time, flight duty period, duty period limitations and rest requirements are established for the sole purpose of ensuring that the flight crew and the cabin crew members are performing at an adequate level of alertness for safe flight operations.

1.2 In order to accomplish this, two types of fatigue should be taken into account, namely, transient fatigue and cumulative fatigue. Transient fatigue may be described as fatigue that is dispelled by a single sufficient period of rest or sleep. Cumulative fatigue occurs after incomplete recovery from transient fatigue over a period of time.

1.3 Limitations based upon the provisions of this Part will provide safeguards against both kinds of fatigue because they will recognize:

- a) the necessity to limit flight duty periods with the aim of preventing both kinds of fatigue;
- b) the necessity to limit the duty period where additional tasks are performed immediately prior to a flight or at intermediate points during a series of flights in such a way as to prevent transient fatigue;
- c) the necessity to limit total flight time and duty periods over specified time spans, in order to prevent cumulative fatigue;
- d) the necessity to provide crew members with adequate rest opportunity to recover from fatigue before commencement of the next flight duty period; and
- e) the necessity of taking into account other related tasks the crew member may be required to perform in order to guard particularly against cumulative fatigue.

2. Operational concepts

2.1 Flight time

The definition of flight time, in the context of flight time limitations, applies to flight and cabin crew members.

2.2 Duty periods

All time spent on duty can induce fatigue in flight and cabin crew members and should therefore be taken into account when arranging rest periods for recovery. Standby may be included as duty if it is likely to induce fatigue.

2.3 Flight duty periods

2.3.1 The definition of flight duty period is intended to cover a continuous period of duty that always includes a flight or series of flights for a flight or cabin crew member. It is meant to include all duties a crew member may be required to carry out from the moment he or she reports for duty until he or she completes the flight or series of flights and the aeroplane finally comes to rest and the engines are shut down. It is considered necessary that a flight duty period should be subject to limitations because a crew member's activities over extended periods would eventually induce fatigue — transient or cumulative — which could adversely affect the safety of a flight.

2.3.2 A flight duty period does not include the period of travelling time from home to the point of reporting for duty. It is the responsibility of the flight or cabin crew member to report for duty in an adequately rested condition.

2.3.3 Time spent positioning at the behest of the operator is part of a flight duty period when this time immediately precedes (i.e., without an intervening rest period) a flight duty period in which that person participates as a flight or cabin crew member.

2.3.4 An important safeguard is for States and operators to recognize the responsibility of a crew member to refuse further flight duty when suffering from fatigue of such a nature as to adversely affect the safety of flight.

2.4 Rest periods

The definition of rest period requires that flight or cabin crew members be relieved of all duties for the purpose of recovering from fatigue. The way in which this recovery is achieved is the responsibility of the flight or cabin crew member. Extended rest periods should be given on a regular basis. Rest periods should not include standby if the conditions of the standby would not enable flight and cabin crew members to recover from fatigue. Suitable accommodation on the ground is required at places where rest periods are taken in order to allow effective recovery.

3. Types of limitations

3.1 Limitations are broadly divided by time. For example, many ICAO Contracting States prescribe daily, monthly and yearly flight time limitations, and a considerable number also prescribe quarterly flight time limitations. In addition, many States also prescribe cumulative duty limitations for specified periods such as consecutive days and seven-day periods. It must be understood, however, that these limitations will vary considerably taking into account a variety of situations.

3.2 To take account of unexpected delays once a flight duty period that has been planned within the allowable limitations has commenced, provision should be made for minimizing the extent to which exceeding the limits may be permitted. Similarly, provision should be made for controlling the extent to which any reduction of rest below that ordinarily required may be allowed in cases where flexibility to recover a delayed schedule is sought. The authority to extend a flight duty period or reduce a rest period within the limitations established is vested in the pilot-in-command.

Note.— See 4.9.2 and 4.11.2.3 for reporting requirements.

3.3 In formulating regulations or rules governing flight time limitations, the crew complement and the extent to which the various tasks to be performed can be divided among the flight or cabin crew members should be taken into account. In the case where additional flight or cabin crew members are carried and facilities in the aeroplane are such that a flight or cabin crew member can obtain recuperative rest in a comfortable reclining seat, or in a bunk, separated and screened from the flight deck and passengers, and reasonably free from disturbance, planned flight duty periods could be extended.

3.4 States should consider all relevant factors, which include: the number and direction of time zones crossed; the time at which a flight duty period is scheduled to begin; the number of planned and/or actual sectors within the flight duty period; the

pattern of working and sleeping relative to the circadian rhythm or 24-hour physiological cycle of the flight or cabin crew; the scheduling of days off; the sequence of early reporting times and late releases from duty; mixing early/late/night duties; and flight operation characteristics.

4. Guidelines for establishing prescriptive limitations for fatigue management

4.1 Purpose and scope

4.1.1 The following material comprises a set of parameters that may be considered in the development of prescriptive limitations for fatigue management.

4.1.2 No numerical values are shown in this example because differences of culture between States can lead to different perceptions as to what is acceptable and what is not. In the text that follows, the symbol (*) is used to indicate where each State may insert a value it considers appropriate to manage fatigue, and square brackets [] to indicate a typical value. States are encouraged to examine the numerical values of other States' systems for further guidance.

4.1.3 When deciding what numerical values should be inserted, States should take into account the results of relevant scientific principles and knowledge, past experience in administering such regulations, cultural issues and the nature of operations intended to be undertaken.

4.1.4 States should assess the adequacy of the breadth and scope of all limitations proposed by each operator as applicable to operations before they approve an operator's flight time and duty period limitations and rest scheme.

4.2 Definitions

4.2.1 Operators and crew members

Augmented flight crew. A flight crew that comprises more than the minimum number required to operate the aeroplane and in which each flight crew member can leave his or her assigned post and be replaced by another appropriately qualified flight crew member for the purpose of in-flight rest.

Cabin crew member. A crew member who performs, in the interest of the safety of passengers, duties assigned by the operator or the pilot-in-command of the aircraft, but who shall not act as a flight crew member.

Crew member. A person assigned by an operator to duty on an aircraft during a flight duty period.

Flight crew member. A licensed crew member charged with duties essential to the operation of an aircraft during a flight duty period.

Operator. A person, organization or enterprise engaged in or offering to engage in an aircraft operation.

4.2.2 Flight or block times

Flight time — aeroplanes. The total time from the moment an aeroplane first moves for the purpose of taking off until the moment it finally comes to rest at the end of the flight.

Note.—“Flight time” as here defined is synonymous with the term “block to block” time or “chock to chock” time in general usage which is measured from the time an aeroplane first moves for the purpose of taking off until it finally stops at the end of the flight.

4.2.3 Duty and flight duty

Duty. Any task that flight or cabin crew members are required by the operator to perform, including, for example, flight duty, administrative work, training, positioning and standby when it is likely to induce fatigue.

Duty period. A period which starts when a flight or cabin crew member is required by an operator to report for or to commence a duty and ends when that person is free from all duties.

Flight duty period. A period which commences when a crew member is required to report for duty that includes a flight or a series of flights and which finishes when the aeroplane finally comes to rest at the end of the last flight on which he/she is a crew member.

4.2.4 Rest period and standby

Rest period. A continuous and defined period of time, subsequent to and/or prior to duty, during which flight or cabin crew members are free of all duties.

Standby. A defined period of time during which a flight or cabin crew member is required by the operator to be available to receive an assignment for a specific duty without an intervening rest period.

4.2.5 General

Home base. The location nominated by the operator to the crew member from where the crew member normally starts and ends a duty period or a series of duty periods.

Positioning. The transferring of a non-operating crew member from place to place as a passenger at the behest of the operator.

Note.—“Positioning” as here defined is synonymous with the term “Deadheading”.

Reporting time. The time at which flight and cabin crew members are required by an operator to report for duty.

Roster. A list provided by an operator of the times when a crew member is required to undertake duties.

Note.—“Roster” as here defined is synonymous with “Schedule”, “Line of Time”, “Pattern”, and “Rotation”.

Suitable accommodation. A furnished bedroom which provides for the opportunity of adequate rest.

Unforeseen operational circumstance. An unplanned event, such as unforecast weather, equipment malfunction, or air traffic delay that is beyond the control of the operator.

4.3 The State’s responsibilities

4.3.1 The objective of any prescriptive limitations for fatigue management regulations is to ensure that flight and cabin crew members remain sufficiently alert so that they can operate to a satisfactory level of performance and safety under all circumstances. The fundamental principle is for every flight and cabin crew member to be adequately rested when he/she

begins a flight duty period and, whilst flying, be sufficiently alert to operate to a satisfactory level of performance and safety in all normal and abnormal situations.

4.3.2 The purpose of this example is to illustrate how limitations might be defined regarding variables likely to influence flight and cabin crew member alertness (e.g., allowable flight hours, duty and flight duty periods, and minimum rest periods) that may be applied when flight and cabin crew rosters are planned. Provision can be made so that some of these limitations could be exceeded, but only on such occasions as could not reasonably have been foreseen when the flight was planned.

4.3.3 This is only one example of how prescriptive limitations for fatigue management may be defined.

4.4 The operator's responsibilities

4.4.1 Operators should reflect in their operations manuals those elements of this example that are appropriate to the operations they undertake. If operations are planned that cannot be managed within the limitations published in the example, a variation may be requested. In this case, and before a variation is approved, an operator should demonstrate to the State of the Operator that the variation provides an equivalent level of safety and that objections on grounds of safety are taken into account.

4.4.2 Duty rosters should be prepared and published sufficiently in advance to provide flight and cabin crew members the opportunity to plan adequate rest. Consideration should be given to the cumulative effects of undertaking long duty hours interspersed with minimum rest, and of avoiding rosters that result in the serious disruption of an established pattern of working and sleeping. Rosters should cover a period of at least (*) days.

4.4.3 Flights should be planned to be completed within the allowable flight duty period taking into account the time necessary for pre-flight duties, the flight and turn-around times, and the nature of the operation. Minimum rest periods needed to provide adequate rest should be based upon the actual operation.

4.4.4 In order to avoid any detriment to a flight or cabin crew member's performance, opportunities to consume a meal must be arranged when the flight duty period exceeds (*) hours.

4.4.5 The operator should nominate a home base for each flight and cabin crew member, from where the flight and cabin crew member will normally start and end a duty period or a series of duty periods. The home base should be assigned with a degree of permanence.

4.4.6 The operator should not require a flight crew member to operate an aeroplane if it is known or suspected that the flight crew member is fatigued to the extent that the safety of flight may be adversely affected.

4.5 Flight crew members' responsibilities

4.5.1 A flight crew member should not operate an aeroplane when he or she knows that he or she is fatigued or feels unfit to the extent that the safety of flight may be adversely affected.

4.5.2 Flight crew members should make best use of the facilities and opportunities that are provided for rest and for the consumption of meals, and should plan and use rest periods to ensure that they are fully rested.

4.6 Flight and cabin crew members

The text that follows specifies limitations that apply to operations by flight and cabin crew members.

4.7 Limitations for flight times and duty periods

4.7.1 *Maximum flight time*

4.7.1.1 The maximum flight time may not exceed:

- a) (*) hours in any flight duty period;
- b) (*) hours in any [7] consecutive days or (*) hours in any [28] consecutive days; and
- c) (*) hours in any [365] consecutive days.

4.7.1.2 The limitations in 4.7.1.1 b) and c) may alternatively be calculated in calendar week, month or year. In such a case other limitations over a period of two or three calendar months should be specified.

4.7.2 *Maximum duty hours for flight crew and cabin crew*

4.7.2.1 Duty hours may not exceed:

- a) (*) hours in any [7] consecutive days or in a week; and
- b) (*) hours in any [28] consecutive days or in a calendar month.

Duty includes all tasks carried out at the behest of the operator. These include, but are not limited to: pre-flight preparation; conduct of the flight (whether or not this is commercial air transport); post-flight actions; training given or received (classroom, flight simulator or aeroplane); rostered office/management time; and positioning. Standby should be included to the extent that it is likely to induce fatigue.

4.7.3 *Maximum flight duty period for flight and cabin crew*

4.7.3.1 The maximum flight duty period should be (*) hours.

4.7.3.1.1 This limitation should allow variation to account for matters known to impact fatigue such as: the number of sectors planned; the local time at which duty begins; the pattern of resting and sleeping relative to the crew member's circadian rhythm; the organization of the working time; and the augmentation of the flight crew.

4.7.3.2 Crew report times should realistically reflect the time required to complete pre-flight duties, both safety- and service-related (if appropriate), and a standard allowance of (*) minutes is to be added at the end of flight time to allow for the completion of checks and records. For record purposes, the pre-flight report time should count both as duty and as flight duty, and the post-flight allowance should count as duty.

4.7.3.3 The maximum flight duty period for cabin crew may be longer than that applicable to the flight crew by the difference in reporting time between flight crew and cabin crew.

4.7.3.4 Flight duty periods may be extended in unforeseen operational circumstances by no more than (*) hour(s) only at the discretion of the pilot-in-command. Before exercising this discretion, the pilot-in-command should be satisfied that all members of the crew required to operate the aeroplane consider themselves fit to do so.

4.7.4 *Flights operated by augmented crews and the provision of in-flight relief*

4.7.4.1 The composition and number of flight crew members carried to provide in-flight relief, and the quality of rest facilities provided, should determine the amount by which the basic flight duty period limitations may be extended. A sensible balance should be kept between the division of in-flight duty and rest. The number of the cabin crew should be determined taking into account the rest facilities provided and other parameters linked to the operation of the flight.

4.7.4.2 The operator should ensure that flight and cabin crew members are notified prior to commencement of the rest period preceding the flight of the role they are required to undertake (i.e., main or relief crew), so that they can plan their pre-flight rest accordingly.

4.8 Minimum rest periods

4.8.1 The minimum rest period immediately before commencing a flight duty period may not be less than (*) hours.

4.8.1.1 Rest provisions should be introduced to take into account the impact of time zone crossings and night operations.

4.8.1.2 Longer rest periods should be granted on a regular basis to preclude cumulative fatigue.

4.8.1.3 Minimum rest periods may be reduced in unforeseen operational circumstances by no more than (*) hour(s) only at the discretion of the pilot-in-command.

4.8.1.4 Travelling time spent by a flight or cabin crew member in transit between the place of rest and the place of reporting for duty is not counted as duty, even though it is a factor contributing to fatigue. Excessive travelling time undertaken immediately before commencing a flight duty period could therefore detract from a flight or cabin crew member's ability to counter fatigue arising whilst on duty, and should therefore be taken into account when deciding where pre-flight rest should be taken.

4.9 Discretion that may be exercised by the pilot-in-command

4.9.1 The pilot-in-command, at his or her discretion in consideration of special circumstances that could lead to unforeseen levels of fatigue and after discussion with flight or cabin crew members affected, may reduce an actual flight duty period and/or increase a minimum rest period (see 4.8.1.3) in order to remove any adverse effect on flight safety.

4.9.2 The pilot-in-command should report to the operator the use of discretion to extend or reduce duty or rest.

4.10 Miscellaneous provisions

4.10.1 *Standby*

4.10.1.1 The start time and end time of standby should be defined and notified at least (*) hours in advance, and the maximum length of any standby should not exceed (*) hours.

4.10.1.2 Where airport standby is immediately followed by a flight duty period, the relationship between such airport standby and the assigned flight duty should be defined. In such a case, airport standby, if it is likely to induce fatigue, should be considered as part of a duty period and should be taken into account to calculate the minimum rest preceding a subsequent flight duty period.

4.10.1.3 When flight and cabin crew members are required to be on standby at an accommodation arranged by the operator, then adequate rest facilities should be provided.

4.10.2 Available

When flight and cabin crew members are required to be available for contact over a brief period of time to receive instructions concerning a possible change of roster, that requirement should not prevent that crew member from having a rest period before reporting for duty. The time spent being available should not be counted as duty.

4.10.3 Positioning

All time spent positioning counts as duty, and positioning followed by operating without an intervening rest period also counts as flight duty. However, positioning should not count as an operating sector when planning or calculating a flight duty period.

4.11 Records

4.11.1 To enable the operator to ascertain that the fatigue management scheme is functioning as intended and as approved, records should be kept for (*) months of the duties performed and rest periods achieved so as to facilitate inspection by the operator's authorized personnel and audit by the State of the Operator.

4.11.2 The operator should ensure that these records include for each flight and cabin crew member, at least:

- a) the start, duration and end of each flight duty period;
- b) the start, duration and end of each duty period;
- c) rest periods; and
- d) flight time.

4.11.3 The operator should also keep records of occasions when a pilot-in-command has exercised his or her discretion (as described in 4.9.1). If discretion has to be applied for similar reasons on more than (*) per cent of occasions when a particular route or route pattern is flown, it is likely that the intention of this guidance is not being met and undue fatigue may result. Arrangements should be made to change the schedule or the crewing arrangements so as to reduce the frequency at which such events occur. A State may require that, in addition, copies of certain records should be submitted.

4.11.4 Flight crew members should maintain a personal record of their daily flight time.

ATTACHMENT B. MEDICAL SUPPLIES

Supplementary to Chapter 6, 6.2.2 a)

TYPES, NUMBER, LOCATION AND CONTENTS OF MEDICAL SUPPLIES

1. Types

1.1 The different types of medical supplies should be provided as follows: first-aid kit(s) for carriage on all aeroplanes, universal precaution kit(s) for carriage on all aeroplanes that require a cabin crew member, and a medical kit for carriage where the aeroplane is authorized to carry more than 100 passengers on a sector length of more than two hours. Where national regulations allow it, operators may elect to carry the recommended medication in the first-aid kit.

1.2 Based on the limited available evidence, only a very small number of passengers are likely to benefit from the carriage of automated external defibrillators (AED) on aeroplanes. However, many operators carry them because they offer the only effective treatment for cardiac fibrillation. The likelihood of use, and therefore of potential benefit to a passenger, is greatest in aircraft carrying a large number of passengers, over long duration sector lengths. The carriage of AEDs should be determined by operators on the basis of a risk assessment taking into account the particular needs of the operation.

2. Number of first-aid and universal precaution kits

2.1 First-aid kits

The number of first-aid kits should be appropriate to the number of passengers which the aeroplane is authorized to carry:

<i>Passenger</i>	<i>First-aid kits</i>
0 – 100	1
101 – 200	2
201 – 300	3
301 – 400	4
401 – 500	5
More than 500	6

2.2 Universal precaution kits

For routine operations, one or two universal precaution kits should be carried on aircraft that are required to operate with at least one cabin crew member. Additional kit(s) should be made available at times of increased public health risk, such as during an outbreak of a serious communicable disease having pandemic potential. Such kits may be used to clean up any potentially infectious body contents such as blood, urine, vomit and faeces and to protect the cabin crew members who are assisting potentially infectious cases of suspected communicable disease.

3. Location

3.1 First-aid and universal precaution kits should be distributed as evenly as practicable throughout the passenger cabins. They should be readily accessible to cabin crew members.

3.2 The medical kit, when carried, should be stored in an appropriate secure location.

4. Contents

4.1 The following provides guidance on typical contents of first-aid, universal precaution and medical kits.

4.1.1 *First-aid kit:*

- List of contents
- Antiseptic swabs (10/pack)
- Bandage: adhesive strips
- Bandage: gauze 7.5 cm × 4.5 m
- Bandage: triangular; safety pins
- Dressing: burn 10 cm × 10 cm
- Dressing: compress, sterile 7.5 cm × 12 cm
- Dressing: gauze, sterile 10.4 cm × 10.4 cm
- Tape: adhesive 2.5 cm (roll)
- Steri-strips (or equivalent adhesive strip)
- Hand cleanser or cleansing towelettes
- Pad with shield, or tape, for eye
- Scissors: 10 cm (if allowed by national regulations)
- Tape: Adhesive, surgical 1.2 cm × 4.6 m
- Tweezers: splinter
- Disposable gloves (multiple pairs)
- Thermometers (non-mercury)
- Mouth-to-mouth resuscitation mask with one-way valve
- First-aid manual, current edition
- Incident record form

The following suggested medications can be included in the first-aid kits where permitted by national regulations:

- Mild to moderate analgesic
- Antiemetic
- Nasal decongestant
- Antacid
- Antihistamine

4.1.2 *Universal precaution kit:*

- Dry powder that can convert small liquid spill into a sterile granulated gel
- Germicidal disinfectant for surface cleaning
- Skin wipes
- Face/eye mask (separate or combined)
- Gloves (disposable)
- Protective apron

- Large absorbent towel
- Pick-up scoop with scraper
- Bio-hazard disposal waste bag
- Instructions

4.1.3 Medical kit:

Equipment

- List of contents
- Stethoscope
- Sphygmomanometer (electronic preferred)
- Airways, oropharyngeal (three sizes)
- Syringes (appropriate range of sizes)
- Needles (appropriate range of sizes)
- Intravenous catheters (appropriate range of sizes)
- Antiseptic wipes
- Gloves (disposable)
- Needle disposal box
- Urinary catheter
- System for delivering intravenous fluids
- Venous tourniquet
- Sponge gauze
- Tape – adhesive
- Surgical mask
- Emergency tracheal catheter (or large gauge intravenous cannula)
- Umbilical cord clamp
- Thermometers (non-mercury)
- Basic life support cards
- Bag-valve mask
- Flashlight and batteries

Medication

- Epinephrine 1:1 000
- Antihistamine – injectable
- Dextrose 50% (or equivalent) – injectable: 50 ml
- Nitroglycerin tablets, or spray
- Major analgesic
- Sedative anticonvulsant – injectable
- Antiemetic – injectable
- Bronchial dilator – inhaler
- Atropine – injectable
- Adrenocortical steroid – injectable
- Diuretic – injectable
- Medication for postpartum bleeding
- Sodium chloride 0.9% (minimum 250 ml)
- Acetyl salicylic acid (aspirin) for oral use
- Oral beta blocker

If a cardiac monitor is available (with or without an AED) add to the above list:

- Epinephrine 1:10 000 (can be a dilution of epinephrine 1:1 000)

Note.— The United Nations Conference for Adoption of a Single Convention on Narcotic Drugs in March 1961 adopted such a Convention, Article 32 of which contains special provisions concerning the carriage of drugs in medical kits of aircraft engaged in international flight.

ATTACHMENT C. AEROPLANE PERFORMANCE OPERATING LIMITATIONS

1. Purpose and scope

The purpose of this Attachment is to provide guidance as to the level of performance intended by the provisions of Chapter 5 as applicable to turbine-powered subsonic transport type aeroplanes over 5 700 kg maximum certificated take-off mass having two or more engines. However, where relevant, it can be applied to all subsonic turbine-powered or piston-engine aeroplanes having two, three or four engines. Piston-engine aeroplanes having two, three or four engines which cannot comply with this Attachment may continue to be operated in accordance with Examples 1 or 2 of this Attachment.

Note.— This Attachment is not intended for application to aeroplanes having short take-off and landing (STOL) or vertical take-off and landing (VTOL) capabilities.

2. Definitions

Accelerate-stop distance available (ASDA). The length of the take-off run available plus the length of the stopway, if provided.

CAS (calibrated airspeed). The calibrated airspeed is equal to the airspeed indicator reading corrected for position and instrument error. (As a result of the sea level adiabatic compressible flow correction to the airspeed instrument dial, CAS is equal to the true airspeed (TAS) in Standard Atmosphere at sea level.)

Declared temperature. A temperature selected in such a way that when used for performance purposes, over a series of operations, the average level of safety is not less than would be obtained by using official forecast temperatures.

Expected. Used in relation to various aspects of performance (e.g. rate or gradient of climb), this term means the standard performance for the type, in the relevant conditions (e.g. mass, altitude and temperature).

Grooved or porous friction course runway. A paved runway that has been prepared with lateral grooving or a porous friction course (PFC) surface to improve braking characteristics when wet.

Height. The vertical distance of a level, a point, or an object considered as a point, measured from a specified datum.

Note.— For the purposes of this example, the point referred to above is the lowest part of the aeroplane and the specified datum is the take-off or landing surface, whichever is applicable.

Landing distance available (LDA). The length of runway which is declared available and suitable for the ground run of an aeroplane landing.

Landing surface. That part of the surface of an aerodrome which the aerodrome authority has declared available for the normal ground or water run of aircraft landing in a particular direction.

Net gradient. The net gradient of climb throughout these requirements is the expected gradient of climb diminished by the manoeuvre performance (i.e. that gradient of climb necessary to provide power to manoeuvre) and by the margin (i.e. that gradient of climb necessary to provide for those variations in performance which are not expected to be taken explicit account of operationally).

Reference humidity. The relationship between temperature and reference humidity is defined as follows:

- at temperatures at and below ISA, 80 per cent relative humidity,
- at temperatures at and above ISA + 28° C, 34 per cent relative humidity,
- at temperatures between ISA and ISA + 28° C, the relative humidity varies linearly between the humidity specified for those temperatures.

Runway surface condition. The state of the surface of the runway: either dry, wet, or contaminated:

- a) *Contaminated runway.* A runway is contaminated when more than 25 per cent of the runway surface area (whether in isolated areas or not) within the required length and width being used is covered by:
 - water, or slush more than 3 mm (0.125 in) deep;
 - loose snow more than 20 mm (0.75 in) deep; or
 - compacted snow or ice, including wet ice.
- b) *Dry runway.* A dry runway is one which is clear of contaminants and visible moisture within the required length and the width being used.
- c) *Wet runway.* A runway that is neither dry nor contaminated.

Note 1.— In certain situations, it may be appropriate to consider the runway contaminated even when it does not meet the above definition. For example, if less than 25 per cent of the runway surface area is covered with water, slush, snow or ice, but it is located where rotation or lift-off will occur, or during the high speed part of the take-off roll, the effect will be far more significant than if it were encountered early in take-off while at low speed. In this situation, the runway should be considered to be contaminated.

Note 2.— Similarly, a runway that is dry in the area where braking would occur during a high speed rejected take-off, but damp or wet (without measurable water depth) in the area where acceleration would occur, may be considered to be dry for computing take-off performance. For example, if the first 25 per cent of the runway was damp, but the remaining runway length was dry, the runway would be wet using the definitions above. However, since a wet runway does not affect acceleration, and the braking portion of a rejected take-off would take place on a dry surface, it would be appropriate to use dry runway take-off performance.

Take-off distance available (TODA). The length of the take-off run available plus the length of the clearway, if provided.

Take-off run available (TORA). The length of runway declared available and suitable for the ground run of an aeroplane taking off.

Take-off surface. That part of the surface of an aerodrome which the aerodrome authority has declared available for the normal ground or water run of aircraft taking off in a particular direction.

TAS (True airspeed). The speed of the aeroplane relative to undisturbed air.

V_{s_0} . A stalling speed or minimum steady flight speed in the landing configuration. (*Note.— See Example 1, 2.4.*)

V_{s_1} . A stalling speed or minimum steady flight speed. (*Note.— See Example 1, 2.5.*)

Note 1.— See Chapter 1 and Annexes 8 and 14, Volume I, for other definitions.

Note 2.— The terms “accelerate-stop distance”, “take-off distance”, “ V_1 ”, “take-off run”, “net take-off flight path”, “one engine inoperative en-route net flight path”, and “two engines inoperative en-route net flight path”, as relating to the aeroplane, have their meanings defined in the airworthiness requirements under which the aeroplane was certificated. If any of these definitions are found inadequate, then a definition specified by the State of the Operator should be used.

3. General

3.1 The provisions of 4 to 7 should be complied with, unless deviations therefrom are specifically authorized by the State of the Operator on the grounds that the special circumstances of a particular case make a literal observance of these provisions unnecessary for safety.

3.2 Compliance with 4 to 7 should be established using performance data in the flight manual and in accordance with other applicable operating requirements. In no case should the limitations in the flight manual be exceeded. However, additional limitations may be applied when operational conditions not included in the flight manual are encountered. The performance data contained in the flight manual may be supplemented with other data acceptable to the State of the Operator if necessary to show compliance with 4 to 7. When applying the factors prescribed in this Attachment, account may be taken of any operational factors already incorporated in the flight manual data to avoid double application of factors.

3.3 The procedures scheduled in the flight manual should be followed except where operational circumstances require the use of modified procedures in order to maintain the intended level of safety.

Note.— See the Airworthiness Manual (Doc 9760) for the related airworthiness performance guidance material.

4. Aeroplane take-off performance limitations

4.1 No aeroplane should commence a take-off at a mass which exceeds the take-off mass specified in the flight manual for the altitude of the aerodrome and for the ambient temperature existing at the time of the take-off.

4.2 No aeroplane should commence a take-off at a mass such that, allowing for normal consumption of fuel and oil in flight to the aerodrome of destination and to the destination alternate aerodromes, the mass on arrival will exceed the landing mass specified in the flight manual for the altitude of each of the aerodromes involved and for the ambient temperatures anticipated at the time of landing.

4.3 No aeroplane should commence a take-off at a mass which exceeds the mass at which, in accordance with the minimum distances for take-off scheduled in the flight manual, compliance with 4.3.1 to 4.3.3 inclusive is shown.

4.3.1 The take-off run required should not exceed the take-off run available.

4.3.2 The accelerate-stop distance required should not exceed the accelerate-stop distance available.

4.3.3 The take-off distance required should not exceed the takeoff distance available.

4.3.4 When showing compliance with 4.3 the same value of V_1 for the continued and discontinued take-off phases should be used.

4.4 When showing compliance with 4.3 the following parameters should be taken into account:

- a) the pressure altitude at the aerodrome;
- b) the ambient temperature at the aerodrome;
- c) the runway surface condition and the type of the runway surface;
- d) the runway slope in the direction of the take-off;
- e) the runway slope;

- f) not more than 50 per cent of the reported headwind component or not less than 150 per cent of the reported tailwind component; and
- g) the loss, if any, of runway length due to alignment of the aeroplane prior to take-off.

4.5 Credit is not taken for the length of the stopway or the length of the clearway unless they comply with the relevant specifications in Annex 14, Volume I.

5. Take-off obstacle clearance limitations

5.1 No aeroplane should commence a take-off at a mass in excess of that shown in the flight manual to correspond with a net take-off flight path which clears all obstacles either by at least a height of 10.7 m (35 ft) vertically or at least 90 m (300 ft) plus 0.125D laterally, where D is the horizontal distance the aeroplane has travelled from the end of take-off distance available, except as provided in 5.1.1 to 5.1.3 inclusive. For aeroplanes with a wingspan of less than 60 m (200 ft) a horizontal obstacle clearance of half the aeroplane wingspan plus 60 m (200 ft), plus 0.125D may be used. In determining the allowable deviation of the net take-off flight path in order to avoid obstacles by at least the distances specified, it is assumed that the aeroplane is not banked before the clearance of the net take-off flight path above obstacles is at least one half of the wingspan but not less than 15.2 m (50 ft) height and that the bank thereafter does not exceed 15°, except as provided in 5.1.4. The net take-off flight path considered is for the altitude of the aerodrome and for the ambient temperature and not more than 50 per cent of the reported headwind component or not less than 150 per cent of the reported tailwind component existing at the time of take-off. The take-off obstacle accountability area defined above is considered to include the effect of crosswinds.

5.1.1 Where the intended track does not include any change of heading greater than 15°,

- a) for operations conducted in VMC by day, or
- b) for operations conducted with navigation aids such that the pilot can maintain the aeroplane on the intended track with the same precision as for operations specified in 5.1.1 a),

obstacles at a distance greater than 300 m (1 000 ft) on either side of the intended track need not be cleared.

5.1.2 Where the intended track does not include any change of heading greater than 15° for operations conducted in IMC, or in VMC by night, except as provided in 5.1.1 b); and where the intended track includes changes of heading greater than 15° for operations conducted in VMC by day, obstacles at a distance greater than 600 m (2 000 ft) on either side of the intended track need not be cleared.

5.1.3 Where the intended track includes changes of heading greater than 15° for operations conducted in IMC, or in VMC by night, obstacles at a distance greater than 900 m (3 000 ft) on either side of the intended track need not be cleared.

5.1.4 An aeroplane may be operated with bank angles of more than 15° below 120 m (400 ft) above the elevation of the end of the take-off run available, provided special procedures are used that allow the pilot to fly the desired bank angles safely under all circumstances. Bank angles should be limited to not more than 20° between 30 m (100 ft) and 120 m (400 ft), and not more than 25° above 120 m (400 ft). Methods approved by the State of the Operator should be used to account for the effect of bank angle on operating speeds and flight path including the distance increments resulting from increased operating speeds. The net take-off flight path in which the aeroplane is banked by more than 15° should clear all obstacles by a vertical distance of at least 10.7 m (35 ft) relative to the lowest part of the banked aeroplane within the horizontal distance specified in 5.1. The use of bank angles greater than those mentioned above should be subject to the approval from the State of the Operator.

6. En-route limitations

6.1 General

At no point along the intended track is an aeroplane having three or more engines to be more than 90 minutes at normal cruising speed away from an aerodrome at which the distance specifications for alternate aerodromes (see 7.3) are complied with and where it is expected that a safe landing can be made, unless it complies with 6.3.1.1.

6.2 One engine inoperative

6.2.1 No aeroplane should commence a take-off at a mass in excess of that which, in accordance with the one-engine-inoperative en-route net flight path data shown in the flight manual, permits compliance either with 6.2.1.1 or 6.2.1.2 at all points along the route. The net flight path has a positive slope at 450 m (1 500 ft) above the aerodrome where the landing is assumed to be made after engine failure. The net flight path used is for the ambient temperatures anticipated along the route. In meteorological conditions where icing protection systems are to be operable, the effect of their use on the net flight path data is taken into account.

6.2.1.1 The slope of the net flight path is positive at an altitude of at least 300 m (1 000 ft) above all terrain and obstructions along the route within 9.3 km (5 NM) on either side of the intended track.

6.2.1.2 The net flight path is such as to permit the aeroplane to continue flight from the cruising altitude to an aerodrome where a landing can be made in accordance with 7.3, the net flight path clearing vertically, by at least 600 m (2 000 ft), all terrain and obstructions along the route within 9.3 km (5 NM) on either side of the intended track. The provisions of 6.2.1.2.1 to 6.2.1.2.5 inclusive are applied.

6.2.1.2.1 The engine is assumed to fail at the most critical point along the route, allowance being made for indecision and navigational error.

6.2.1.2.2 Account is taken of the effects of winds on the flight path.

6.2.1.2.3 Fuel jettisoning is permitted to an extent consistent with reaching the aerodrome with satisfactory fuel reserves, if a safe procedure is used.

6.2.1.2.4 The aerodrome, where the aeroplane is assumed to land after engine failure, is specified in the operational flight plan, and it meets the appropriate aerodrome operating minima at the expected time of use.

6.2.1.2.5 The consumption of fuel and oil after the engine becomes inoperative is that which is accounted for in the net flight path data shown in the flight manual.

6.3 Two engines inoperative — aeroplanes with three or more engines

6.3.1 Aeroplanes which do not comply with 6.1 should comply with 6.3.1.1.

6.3.1.1 No aeroplane should commence a take-off at a mass in excess of that which, according to the two-engine inoperative en-route net flight path data shown in the flight manual, permits the aeroplane to continue the flight from the point where two engines are assumed to fail simultaneously, to an aerodrome at which the landing distance specification for alternate aerodromes (see 7.3) is complied with and where it is expected that a safe landing can be made. The net flight path clears vertically, by at least 600 m (2 000 ft) all terrain and obstructions along the route within 9.3 km (5 NM) on either side of the intended track. The net flight path considered is for the ambient temperatures anticipated along the route. In altitudes and

meteorological conditions where icing protection systems are to be operable, the effect of their use on the net flight path data is taken into account. The provisions of 6.3.1.1.1 to 6.3.1.1.5 inclusive apply.

6.3.1.1.1 The two engines are assumed to fail at the most critical point of that portion of the route where the aeroplane is at more than 90 minutes at normal cruising speed away from an aerodrome at which the landing distance specification for alternate aerodromes (see 7.3) is complied with and where it is expected that a safe landing can be made.

6.3.1.1.2 The net flight path has a positive slope at 450 m (1 500 ft) above the aerodrome where the landing is assumed to be made after the failure of two engines.

6.3.1.1.3 Fuel jettisoning is permitted to an extent consistent with 6.3.1.1.4, if a safe procedure is used.

6.3.1.1.4 The aeroplane mass at the point where the two engines are assumed to fail is considered to be not less than that which would include sufficient fuel to proceed to the aerodrome and to arrive there at an altitude of at least 450 m (1 500 ft) directly over the landing area and thereafter to fly for 15 minutes at cruise power and/or thrust.

6.3.1.1.5 The consumption of fuel and oil after the engines become inoperative is that which is accounted for in the net flight path data shown in the flight manual.

7. Landing limitations

7.1 Aerodrome of destination — dry runways

7.1.1 No aeroplane should commence a take-off at a mass in excess of that which permits the aeroplane to be brought to a full stop landing at the aerodrome of intended destination from 15.2 m (50 ft) above the threshold:

- a) for turbo jet powered aeroplanes, within 60 per cent of the landing distance available; and
- b) for turbo-propeller aeroplanes, within 70 per cent of the landing distance available.

The mass of the aeroplane is assumed to be reduced by the mass of the fuel and oil expected to be consumed in flight to the aerodrome of intended destination. Compliance is shown with 7.1.1.1 and with either 7.1.1.2 or 7.1.1.3.

7.1.1.1 It is assumed that the aeroplane is landed on the most favourable runway and in the most favourable direction in still air.

7.1.1.2 It is assumed that the aeroplane is landed on the runway which is the most suitable for the wind conditions anticipated at the aerodrome at the time of landing, taking due account of the probable wind speed and direction, of the ground handling characteristics of the aeroplane, and of other conditions (i.e. landing aids, terrain).

7.1.1.3 If full compliance with 7.1.1.2 is not shown, the aeroplane may be taken off if a destination alternate aerodrome is designated which permits compliance with 7.3.

7.1.1.4 When showing compliance with 7.1.1 at least the following factors should be taken into account:

- a) the pressure altitude of the aerodrome;
- b) the runway slope in the direction of the landing if greater than ± 2.0 per cent; and
- c) not more than 50 per cent of the headwind component or not less than 150 per cent of the tailwind component.

7.2 Aerodrome of destination — wet or contaminated runways

7.2.1 When the appropriate weather reports or forecasts or a combination thereof indicate that the runway at the estimated time of arrival may be wet, the landing distance available should be at least 115 per cent of the required landing distance determined in accordance with 7.1.

7.2.2 A landing distance on a wet runway shorter than that required by 7.2.1 but not less than that required by 7.1 may be used if the flight manual includes specific additional information about landing distance on wet runways.

7.2.3 When the appropriate weather reports or forecasts or a combination thereof indicate that the runway at the estimated time of arrival may be contaminated, the landing distance available should be the greater of:

- a) the landing distance determined in accordance with 7.2.1; or
- b) the landing distance determined in accordance with contaminated landing distance data with a safety margin acceptable to the State of the Operator.

7.2.4 If compliance with 7.2.3 is not shown, the aeroplane may take off if a destination alternate aerodrome is designated for which compliance is shown with 7.2.3 and 7.3.

7.2.5 When showing compliance with 7.2.2 and 7.2.3, the criteria of 7.1 should be applied accordingly. However, 7.1.1 a) and b) need not be applied to the wet and contaminated runway landing distance determination required by 7.2.2 and 7.2.3.

7.3 Destination alternate aerodrome

No aerodrome should be designated as a destination alternate aerodrome unless the aeroplane, at the mass anticipated at the time of arrival at such aerodrome, can comply with 7.1 and either 7.2.1 or 7.2.2, in accordance with the landing distance required for the altitude of the alternate aerodrome and in accordance with other applicable operating requirements for the alternate aerodrome.

7.4 Performance considerations before landing

The operator should provide the flight crew with a method to ensure that a full stop landing, with a safety margin acceptable to the State of the Operator, that is at least the minimum specified in the Type Certificate holder's aircraft flight manual (AFM), or equivalent, can be made on the runway to be used in the conditions existing at the time of landing and with the deceleration means that will be used.

Example 1

1. Purpose and scope

The purpose of the following example is to illustrate the level of performance intended by the provisions of Chapter 5 as applicable to the types of aeroplanes described below.

The Standards and Recommended Practices in Annex 6 effective on 14 July 1949 contained specifications similar to those adopted by some Contracting States for inclusion in their national performance codes. A very substantial number of civil transport aeroplanes have been manufactured and are being operated in accordance with these codes. Those aeroplanes are powered with reciprocating engines including turbo-compound design. They embrace twin-engined and four-engined aeroplanes over a mass range from approximately 4 200 kg to 70 000 kg over a stalling speed range, V_{S0} from approximately 100 to 175 km/h (55 to 95 kt) and over a wing loading range from approximately 120 to 360 kg/m². Cruising speeds range over 555 km/h (300 kt). Those aeroplanes have been used in a very wide range of altitude, air temperature and humidity conditions. At a later date, the code was applied with respect to the evaluation of certification of the so-called “first generation” of turboprop and turbo-jet aeroplanes.

Although only past experience can warrant the fact that this example illustrates the level of performance intended by the Standards and Recommended Practices of Chapter 5, it is considered to be applicable over a wide range of aeroplane characteristics and atmospheric conditions. Reservation should however be made concerning the application of this example with respect to conditions of high air temperatures. In certain extreme cases, it has been found desirable to apply additional temperature and/or humidity accountability, particularly for the obstacle limited take-off flight path.

This example is not intended for application to aeroplanes having short take-off and landing (STOL) or vertical take-off and landing (VTOL) capabilities.

No detailed study has been made of the applicability of this example to operations in all-weather conditions. The validity of this example has not therefore been established for operations which may involve low decision heights and be associated with low minima operating techniques and procedures.

2. Stalling speed — minimum steady flight speed

2.1 For the purpose of this example, the stalling speed is the speed at which an angle of attack greater than that of maximum lift is reached, or, if greater, the speed at which a large amplitude pitching or rolling motion, not immediately controllable, is encountered, when the manoeuvre described in 2.3 is executed.

Note.— It should be noted that an uncontrollable pitching motion of small amplitude associated with pre-stall buffeting does not necessarily indicate that the stalling speed has been reached.

2.2 The minimum steady flight speed is that obtained while maintaining the elevator control in the most rearward possible position when the manoeuvre described in 2.3 is executed. This speed would not apply when the stalling speed defined in 2.1 occurs before the elevator control reaches its stops.

2.3 Determination of stalling speed — minimum steady flight speed

2.3.1 The aeroplane is trimmed for a speed of approximately $1.4V_{S1}$. From a value sufficiently above the stalling speed to ensure that a steady rate of decrease is obtainable, the speed is reduced in straight flight at a rate not exceeding 0.5 m/s² (1 kt/s) until the stalling speed or the minimum steady flight speed, defined in 2.1 and 2.2, is reached.

2.3.2 For the purpose of measuring stalling speed and minimum steady flight speed, the instrumentation is such that the probable error of measurement is known.

2.4 V_{s_0}

V_{s_0} denotes the stalling speed if obtained in flight tests conducted in accordance with 2.3, or the minimum steady flight speed, CAS, as defined in 2.2, with:

- a) engines at not more than sufficient power for zero thrust at a speed not greater than 110 per cent of the stalling speed;
- b) propeller pitch controls in the position recommended for normal use during take-off;
- c) landing gear extended;
- d) wing flaps in the landing position;
- e) cowl flaps and radiator shutters closed or nearly closed;
- f) centre of gravity in that position within the permissible landing range which gives the maximum value of stalling speed or of minimum steady flight speed;
- g) aeroplane mass equal to the mass involved in the specification under consideration.

2.5 V_{s_1}

V_{s_1} denotes the stalling speed if obtained in flight tests conducted in accordance with 2.3, or the minimum steady flight speed, CAS, as defined in 2.2, with:

- a) engines at not more than sufficient power for zero thrust at a speed not greater than 110 per cent of the stalling speed;
- b) propeller pitch controls in the position recommended for normal use during take-off;
- c) aeroplane in the configuration in all other respects and at the mass prescribed in the specification under consideration.

3. Take-off

3.1 Mass

The mass of the aeroplane at take-off is not to exceed the maximum take-off mass specified in the flight manual for the altitude at which the take-off is to be made.

3.2 Performance

The performance of the aeroplane as determined from the information contained in the flight manual is such that:

- a) the accelerate-stop distance required does not exceed the accelerate-stop distance available;

- b) the take-off distance required does not exceed the take-off distance available;
- c) the take-off path provides a vertical clearance of not less than 15.2 m up to $D = 500$ m (50 ft up to $D = 1\,500$ ft) and $15.2 + 0.01 [D - 500]$ m ($50 + 0.01 [D - 1\,500]$ ft) thereafter, above all obstacles lying within 60 m plus half the wing span of the aeroplane plus $0.125D$ on either side of the flight path, except that obstacles lying beyond 1 500 m on either side of the flight path need not be cleared.

The distance D is the horizontal distance that the aeroplane has travelled from the end of the take-off distance available.

Note.— This need not be carried beyond the point at which the aeroplane would be able, without further gaining in height, to commence a landing procedure at the aerodrome of take-off or, alternatively, has attained the minimum safe altitude for commencing flight to another aerodrome.

However, the lateral obstacle clearance is liable to be reduced (below the values stated above) when, and to the extent that, this is warranted by special provisions or conditions which assist the pilot to avoid inadvertent lateral deviations from the intended flight path. For example, particularly in poor weather conditions, a precise radio aid may assist the pilot to maintain the intended flight path. Also, when the take-off is made in sufficiently good visibility conditions, it may, in some cases, be possible to avoid obstacles which are clearly visible but may be within the lateral limits noted in 3.2 c).

Note 1.— The procedures used in defining the accelerate-stop distance required, the take-off distance required and the take-off flight path are described in the Appendix to this example.

Note 2.— In some national codes similar to this example, the specification for “performance” at take-off is such that no credit can be taken for any increase in length of accelerate-stop distance available and take-off distance available beyond the length specified in Section 1 for take-off run available. Those codes specify a vertical clearance of not less than 15.2 m (50 ft) above all obstacles lying within 60 m on either side of the flight path while still within the confines of the aerodrome, and 90 m on either side of the flight path when outside those confines. It is to be observed that those codes are such that they do not provide for an alternative to the method of elements (see the Appendix to this example) in the determination of the take-off path. It is considered that those codes are compatible with the general intent of this example.

3.3 Conditions

For the purpose of 3.1 and 3.2, the performance is that corresponding to:

- a) the mass of the aeroplane at the start of take-off;
- b) an altitude equal to the elevation of the aerodrome;

and for the purpose of 3.2:

- c) the ambient temperature at the time of take-off for 3.2 a) and b) only;
- d) the runway slope in the direction of take-off (landplanes);
- e) not more than 50 per cent of the reported wind component opposite to the direction of take-off, and not less than 150 per cent of the reported wind component in the direction of take-off. In certain cases of operation of seaplanes, it has been found necessary to take account of the reported wind component normal to the direction of take-off.

3.4 Critical point

In applying 3.2 the critical point chosen for establishing compliance with 3.2 a) is not nearer to the starting point than that used for establishing compliance with 3.2 b) and 3.2 c).

3.5 Turns

In case the flight path includes a turn with bank greater than 15 degrees, the clearances specified in 3.2 c) are increased by an adequate amount during the turn, and the distance D is measured along the intended track.

4. En route

4.1 One engine inoperative

4.1.1 At all points along the route or planned diversion therefrom, the aeroplane is capable, at the minimum flight altitudes en route, of a steady rate of climb with one engine inoperative, as determined from the flight manual, of at least

$$1) \quad K \left(\frac{V_{s_o}}{185.2} \right)^2 \text{ m/s, } V_{s_o} \text{ being expressed in km/h;}$$

$$2) \quad K \left(\frac{V_{s_o}}{100} \right)^2 \text{ m/s, } V_{s_o} \text{ being expressed in kt;}$$

$$3) \quad K \left(\frac{V_{s_o}}{100} \right)^2 \text{ ft/min, } V_{s_o} \text{ being expressed in kt;}$$

and K having the following value:

$$K = 4.04 - \frac{5.40}{N} \text{ in the case of 1) and 2); and}$$

$$K = 797 - \frac{1\,060}{N} \text{ in the case of 3)}$$

where N is the number of engines installed.

It should be noted that minimum flight altitudes are usually considered to be not less than 300 m (1 000 ft) above terrain along and adjacent to the flight path.

4.1.2 As an alternative to 4.1.1 the aeroplane is operated at an all engines operating altitude such that, in the event of an engine failure, it is possible to continue the flight to an aerodrome where a landing can be made in accordance with 5.3, the flight path clearing all terrain and obstructions along the route within 8 km (4.3 NM) on either side of the intended track by at least 600 m (2 000 ft). In addition, if such a procedure is utilized, the following provisions are complied with:

- a) the rate of climb, as determined from the flight manual for the appropriate mass and altitude, used in calculating the flight path is diminished by an amount equal to

$$1) \quad K \left(\frac{V_{s_o}}{185.2} \right)^2 \text{ m/s, } V_{s_o} \text{ being expressed in km/h;}$$

$$2) \quad K \left(\frac{V_{s_0}}{100} \right)^2 \text{ m/s, } V_{s_0} \text{ being expressed in kt;}$$

$$3) \quad K \left(\frac{V_{s_0}}{100} \right)^2 \text{ ft/min, } V_{s_0} \text{ being expressed in kt;}$$

and K having the following value:

$$K = 4.04 - \frac{5.40}{N} \text{ in the case of 1) and 2); and}$$

$$K = 797 - \frac{1\ 060}{N} \text{ in the case of 3)}$$

where N is the number of engines installed;

- b) the aeroplane complies with 4.1.1 at 300 m (1 000 ft) above the aerodrome used as an alternate in this procedure;
- c) after the engine failure considered, account is taken of the effect of winds and temperatures on the flight path;
- d) it is assumed that the mass of the aeroplane as it proceeds along its intended track is progressively reduced by normal consumption of fuel and oil;
- e) it is customary to assume such fuel jettisoning as is consistent with reaching the aerodrome in question.

4.2 Two engines inoperative (applicable only to aeroplanes with four engines)

The possibility of two engines becoming inoperative when the aeroplane is more than 90 minutes at all engines operating cruising speed from an en-route alternate aerodrome is catered for. This is done by verifying that at whatever such point such a double failure may occur, the aeroplane in the configuration and with the engine power specified in the flight manual can thereafter reach the alternate aerodrome without coming below the minimum flight altitude. It is customary to assume such fuel jettisoning as is consistent with reaching the aerodrome in question.

5. Landing

5.1 Mass

The calculated mass for the expected time of landing at the aerodrome of intended landing or any destination alternate aerodrome is not to exceed the maximum specified in the flight manual for the elevation of that aerodrome.

5.2 Landing distance

5.2.1 Aerodrome of intended landing

The landing distance at the aerodrome of the intended landing, as determined from the flight manual, is not to exceed 60 per cent of the landing distance available on:

- a) the most suitable landing surface for a landing in still air; and, if more severe,
- b) any other landing surface that may be required for landing because of expected wind conditions at the time of arrival.

5.2.2 Alternate aerodromes

The landing distance at any alternate aerodrome, as determined from the flight manual, is not to exceed 70 per cent of the landing distance available on:

- a) the most suitable landing surface for a landing in still air; and, if more severe,
- b) any other landing surface that may be required for landing because of expected wind conditions at the time of arrival.

Note.— The procedure used in determining the landing distance is described in the Appendix to this example.

5.3 Conditions

For the purpose of 5.2, the landing distances are not to exceed those corresponding to:

- a) the calculated mass of the aeroplane for the expected time of landing;
- b) an altitude equal to the elevation of the aerodrome;
- c) for the purpose of 5.2.1 a) and 5.2.2 a), still air;
- d) for the purpose of 5.2.1 b) and 5.2.2 b), not more than 50 per cent of the expected wind component along the landing path and opposite to the direction of landing and not less than 150 per cent of the expected wind component in the direction of landing.

APPENDIX TO EXAMPLE 1 ON AEROPLANE PERFORMANCE OPERATING LIMITATIONS — PROCEDURES USED IN DETERMINING TAKE-OFF AND LANDING PERFORMANCE

1. General

1.1 Unless otherwise specified, Standard Atmosphere and still air conditions are applied.

1.2 Engine powers are based on a water vapour pressure corresponding to 80 per cent relative humidity in standard conditions. When performance is established for temperature above standard, the water vapour pressure for a given altitude is assumed to remain at the value stated above for standard atmospheric conditions.

1.3 Each set of performance data required for a particular flight condition is determined with the engine accessories absorbing the normal amount of power appropriate to that flight condition.

1.4 Various wing flap positions are selected. These positions are permitted to be made variable with mass, altitude and temperature in so far as this is considered consistent with acceptable operating practices.

1.5 The position of the centre of gravity is selected within the permissible range so that the performance achieved in the configuration and power indicated in the specification under consideration is a minimum.

1.6 The performance of the aeroplane is determined in such a manner that under all conditions the approved limitations for the engine are not exceeded.

1.7 The determined performance is so scheduled that it can serve directly in showing compliance with the aeroplane performance operating limitations.

2. Take-off

2.1 General

2.1.1 The take-off performance data are determined:

a) for the following conditions:

- 1) sea level;
- 2) aeroplane mass equal to the maximum take-off mass at sea level;
- 3) level, smooth, dry and hard take-off surfaces (landplanes);
- 4) smooth water of declared density (seaplanes);

b) over selected ranges of the following variables:

- 1) atmospheric conditions, namely: altitude and also pressure-altitude and temperature;
- 2) aeroplane mass;
- 3) steady wind velocity parallel to the direction of take-off;
- 4) steady wind velocity normal to the direction of take-off (seaplanes);
- 5) uniform take-off surface slope (landplanes);
- 6) type of take-off surface (landplanes);
- 7) water surface condition (seaplanes);
- 8) density of water (seaplanes);
- 9) strength of current (seaplanes).

2.1.2 The methods of correcting the performance data to obtain data for adverse atmospheric conditions include appropriate allowance for any increased airspeeds and cowl flap or radiator shutter openings necessary under such conditions to maintain engine temperatures within appropriate limits.

2.1.3 For seaplanes appropriate interpretations of the term landing gear, etc., are made to provide for the operation of retractable floats, if employed.

2.2 Take-off safety speed

2.2.1 The take-off safety speed is an airspeed (CAS) so selected that it is not less than:

- a) $1.20V_{s1}$, for aeroplanes with two engines;
- b) $1.15V_{s1}$, for aeroplanes having more than two engines;
- c) 1.10 times the minimum control speed, V_{MC} established as prescribed in 2.3;

where V_{s1} is appropriate to the configuration, as described in 2.3.1 b), c) and d).

2.3 Minimum control speed

2.3.1 The minimum control speed, V_{MC} , is determined not to exceed a speed equal to $1.2V_{s1}$ where V_{s1} corresponds with the maximum certificated take-off mass with:

- a) maximum take-off power on all engines;
- b) landing gear retracted;
- c) wing flaps in take-off position;
- d) cowl flaps and radiator shutters in the position recommended for normal use during take-off;
- e) aeroplane trimmed for take-off;
- f) aeroplane airborne and ground effect negligible.

2.3.2 The minimum control speed is such that, when any one engine is made inoperative at that speed, it is possible to recover control of the aeroplane with the one engine still inoperative and to maintain the aeroplane in straight flight at that speed either with zero yaw or with a bank not in excess of 5 degrees.

2.3.3 From the time at which the engine is made inoperative to the time at which recovery is complete, exceptional skill, alertness, or strength on the part of the pilot is not required to prevent any loss of altitude other than that implicit in the loss of performance or any change of heading in excess of 20 degrees, nor does the aeroplane assume any dangerous attitude.

2.3.4 It is demonstrated that to maintain the aeroplane in steady straight flight at this speed after recovery and before retrimming does not require a rudder control force exceeding 800 N and does not make it necessary for the flight crew to reduce the power of the remaining engines.

2.4 Critical point

2.4.1 The critical point is a selected point at which, for the purpose of determining the accelerate-stop distance and the take-off path, failure of the critical engine is assumed to occur. The pilot is provided with a ready and reliable means of determining when the critical point has been reached.

2.4.2 If the critical point is located so that the airspeed at that point is less than the take-off safety speed, it is demonstrated that, in the event of sudden failure of the critical engine at all speeds down to the lowest speed corresponding with the critical point, the aeroplane is controllable satisfactorily and that the take-off can be continued safely, using normal piloting skill, without reducing the thrust of the remaining engines.

2.5 Accelerate-stop distance required

2.5.1 The accelerate-stop distance required is the distance required to reach the critical point from a standing start and, assuming the critical engine to fail suddenly at this point, to stop if a landplane, or to bring the aeroplane to a speed of approximately 6 km/h (3 kt) if a seaplane.

2.5.2 Use of braking means in addition to, or in lieu of, wheel brakes is permitted in determining this distance, provided that they are reliable and that the manner of their employment is such that consistent results can be expected under normal conditions of operation, and provided that exceptional skill is not required to control the aeroplane.

2.5.3 The landing gear remains extended throughout this distance.

2.6 Take-off path

2.6.1 General

2.6.1.1 The take-off path is determined either by the method of elements, 2.6.2, or by the continuous method, 2.6.3, or by any acceptable combination of the two.

2.6.1.2 Adjustment of the provisions of 2.6.2.1 c) 1) and 2.6.3.1 c) is permitted when the take-off path would be affected by the use of an automatic pitch changing device, provided that a level of performance safety exemplified by 2.6 is demonstrated.

2.6.2 Method of elements

2.6.2.1 In order to define the take-off path, the following elements are determined:

- a) The distance required to accelerate the aeroplane from a standing start to the point at which the take-off safety speed is first attained, subject to the following provisions:
 - 1) the critical engine is made inoperative at the critical point;
 - 2) the aeroplane remains on or close to the ground;
 - 3) the landing gear remains extended.
- b) The horizontal distance traversed and the height attained by the aeroplane operating at the take-off safety speed during the time required to retract the landing gear, retraction being initiated at the end of 2.6.2.1 a) with:
 - 1) the critical engine inoperative, its propeller windmilling, and the propeller pitch control in the position recommended for normal use during take-off, except that, if the completion of the retraction of the landing gear occurs later than the completion of the stopping of the propeller initiated in accordance with 2.6.2.1 c) 1), the propeller may be assumed to be stopped throughout the remainder of the time required to retract the landing gear;

- 2) the landing gear extended.
- c) When the completion of the retraction of the landing gear occurs earlier than the completion of the stopping of the propeller, the horizontal distance traversed and the height attained by the aeroplane in the time elapsed from the end of 2.6.2.1 b) until the rotation of the inoperative propeller has been stopped, when:
 - 1) the operation of stopping the propeller is initiated not earlier than the instant the aeroplane has attained a total height of 15.2 m (50 ft) above the take-off surface;
 - 2) the aeroplane speed is equal to the take-off safety speed;
 - 3) the landing gear is retracted;
 - 4) the inoperative propeller is windmilling with the propeller pitch control in the position recommended for normal use during take-off.
- d) The horizontal distance traversed and the height attained by the aeroplane in the time elapsed from the end of 2.6.2.1 c) until the time limit on the use of take-off power is reached, while operating at the take-off safety speed, with:
 - 1) the inoperative propeller stopped;
 - 2) the landing gear retracted.

The elapsed time from the start of the take-off need not extend beyond a total of 5 minutes.

- e) The slope of the flight path with the aeroplane in the configuration prescribed in 2.6.2.1 d) and with the remaining engine(s) operating within the maximum continuous power limitations, where the time limit on the use of take-off power is less than 5 minutes.

2.6.2.2 If satisfactory data are available, the variations in drag of the propeller during feathering and of the landing gear throughout the period of retraction are permitted to be taken into account in determining the appropriate portions of the elements.

2.6.2.3 During the take-off and subsequent climb represented by the elements, the wing flap control setting is not changed, except that changes made before the critical point has been reached, and not earlier than 1 minute after the critical point has been passed, are permitted; in this case, it is demonstrated that such changes can be accomplished without undue skill, concentration, or effort on the part of the pilot.

2.6.3 *Continuous method*

2.6.3.1 The take-off path is determined from an actual take-off during which:

- a) the critical engine is made inoperative at the critical point;
- b) the climb-away is not initiated until the take-off safety speed has been reached and the airspeed does not fall below this value in the subsequent climb;
- c) retraction of the landing gear is not initiated before the aeroplane reaches the take-off safety speed;
- d) the wing flap control setting is not changed, except that changes made before the critical point has been reached, and not earlier than 1 minute after the critical point has been passed, are permitted; in this case, it is demonstrated that such changes can be accomplished without undue skill, concentration, or effort on the part of the pilot;

- e) the operation of stopping the propeller is not initiated until the aeroplane has cleared a point 15.2 m (50 ft) above the take-off surface.

2.6.3.2 Suitable methods are provided and employed to take into account, and to correct for, any vertical gradient of wind velocity which may exist during the take-off.

2.7 Take-off distance required

The take-off distance required is the horizontal distance along the take-off flight path from the start of the take-off to a point where the aeroplane attains a height of 15.2 m (50 ft) above the take-off surface.

2.8 Temperature accountability

Operating correction factors for take-off mass and take-off distance are determined to account for temperature above and below those of the Standard Atmosphere. These factors are obtained as follows:

- a) For any specific aeroplane type the average full temperature accountability is computed for the range of mass and altitudes above sea level, and for ambient temperatures expected in operation. Account is taken of the temperature effect both on the aerodynamic characteristics of the aeroplane and on the engine power. The full temperature accountability is expressed per degree of temperature in terms of a mass correction, a take-off distance correction and a change, if any, in the position of the critical point.
- b) Where 2.6.2 is used to determine the take-off path, the operating correction factors for the aeroplane mass and take-off distance are at least one half of the full accountability values. Where 2.6.3 is used to determine the take-off path, the operating correction factors for the aeroplane mass and take-off distance are equal to the full accountability values. With both methods, the position of the critical point is further corrected by the average amount necessary to assure that the aeroplane can stop within the runway length at the ambient temperature, except that the speed at the critical point is not less than a minimum at which the aeroplane can be controlled with the critical engine inoperative.

3. Landing

3.1 General

The landing performance is determined:

- a) for the following conditions:
 - 1) sea level;
 - 2) aeroplane mass equal to the maximum landing mass at sea level;
 - 3) level, smooth, dry and hard landing surfaces (landplanes);
 - 4) smooth water of declared density (seaplanes);
- b) over selected ranges of the following variables:
 - 1) atmospheric conditions, namely: altitude and also pressure-altitude and temperature;

- 2) aeroplane mass;
- 3) steady wind velocity parallel to the direction of landing;
- 4) uniform landing-surface slope (landplanes);
- 5) type of landing surface (landplanes);
- 6) water surface condition (seaplanes);
- 7) density of water (seaplanes);
- 8) strength of current (seaplanes).

3.2 Landing distance

The landing distance is the horizontal distance between that point on the landing surface at which the aeroplane is brought to a complete stop or, for seaplanes, to a speed of approximately 6 km/h (3 kt) and that point on the landing surface which the aeroplane cleared by 15.2 m (50 ft).

3.3 Landing technique

3.3.1 In determining the landing distance:

- a) immediately before reaching the 15.2 m (50 ft) height, a steady approach is maintained, landing gear fully extended, with an airspeed of not less than $1.3V_{s_0}$;
- b) the nose of the aeroplane is not depressed in flight nor the forward thrust increased by application of engine power after reaching the 15.2 m (50 ft) height;
- c) the wing flap control is set in the landing position, and remains constant during the final approach, flare out and touch down, and on the landing surface at air speeds above $0.9V_{s_0}$. When the aeroplane is on the landing surface and the airspeed has fallen to less than $0.9V_{s_0}$, change of the wing-flap-control setting is permitted;
- d) the landing is made in a manner such that there is no excessive vertical acceleration, no excessive tendency to bounce, and no display of any uncontrollable or otherwise undesirable ground (water) handling characteristics, and such that its repetition does not require either an exceptional degree of skill on the part of the pilot, or exceptionally favourable conditions;
- e) wheel brakes are not used in a manner such as to produce excessive wear of brakes or tires, and the operating pressures on the braking system are not in excess of those approved.

3.3.2 In addition to, or in lieu of, wheel brakes, other reliable braking means are permitted to be used in determining the landing distance, provided that the manner of their employment is such that consistent results can be expected under normal conditions of operation and that exceptional skill is not required to control the aeroplane.

3.3.3 The gradient of the steady approach and the details of the technique used in determining the landing distance, together with such variations in the technique as are recommended for landing with the critical engines inoperative, and any appreciable variation in landing distance resulting therefrom, are entered in the flight manual.

Example 2

1. Purpose and scope

The purpose of the following example is to illustrate the level of performance intended by the provisions of Chapter 5 as applicable to the types of aeroplanes described below.

This material was contained in substance in Attachment A to the now superseded edition of Annex 6 which became effective on 1 May 1953. It is based on the type of requirements developed by the Standing Committee on Performance* with such detailed changes as are necessary to make it reflect as closely as possible a performance code that has been used nationally.

A substantial number of civil transport aeroplanes have been manufactured and are being operated in accordance with these codes. Those aeroplanes are powered with reciprocating engines, turbo-propellers and turbo-jets. They embrace twin-engined and four-engined aeroplanes over a mass range from approximately 5 500 kg to 70 000 kg over a stalling speed range, V_{s_0} , from approximately 110 to 170 km/h (60 to 90 kt) and over a wing loading range from approximately 120 to 350 kg/m². Cruising speeds range up to 740 km/h (400 kt). Those aeroplanes have been used in a very wide range of altitude, air temperature and humidity conditions.

Although only past experience can warrant the fact that this example illustrates the level of performance intended by the Standards and Recommended Practices of Chapter 5, it is considered to be applicable, except for some variations in detail as necessary to fit particular cases, over a much wider range of aeroplane characteristics. Reservation should, however, be made concerning one point. The landing distance specification of this example, not being derived from the same method as other specifications, is valid only for the range of conditions stated for Example 1 in this Attachment.

This example is not intended for application to aeroplanes having short take-off and landing (STOL) or vertical take-off and landing (VTOL) capabilities.

No detailed study has been made of the applicability of this example to operations in all-weather conditions. The validity of this example has not therefore been established for operations which may involve low decision heights and be associated with low weather minima operating techniques and procedures.

2. Take-off

2.1 Mass

The mass of the aeroplane at take-off is not to exceed the maximum take-off mass specified in the flight manual for the altitude and temperature at which the take-off is to be made.

2.2 Performance

The performance of the aeroplane, as determined from the information contained in the flight manual, is such that:

* The ICAO Standing Committee on Performance, established as a result of recommendations of the Airworthiness and Operations Divisions at their Fourth Sessions, in 1951, met four times between 1951 and 1953.

- a) the accelerate-stop distance required does not exceed the accelerate-stop distance available;
- b) the take-off run required does not exceed the take-off run available;
- c) the take-off distance required does not exceed the take-off distance available;
- d) the net take-off flight path starting at a point 10.7 m (35 ft) above the ground at the end of the take-off distance required provides a vertical clearance of not less than 6 m (20 ft) plus $0.005D$ above all obstacles lying within 60 m plus half the wing span of the aeroplane plus $0.125D$ on either side of the intended track until the relevant altitude laid down in the operations manual for an en-route flight has been attained; except that obstacles lying beyond 1 500 m on either side of the flight path need not be cleared.

The distance D is the horizontal distance that the aeroplane has travelled from the end of the take-off distance available.

Note.— This need not be carried beyond the point at which the aeroplane would be able, without further gaining in height, to commence a landing procedure at the aerodrome of take-off or, alternatively, has attained the minimum safe altitude for commencing flight to another aerodrome.

However, the lateral obstacle clearance is liable to be reduced (below the values stated above) when, and to the extent that, this is warranted by special provisions or conditions which assist the pilot to avoid inadvertent lateral deviations from the intended flight path. For example, particularly in poor weather conditions, a precise radio aid may assist the pilot to maintain the intended flight path. Also, when the take-off is made in sufficiently good visibility conditions, it may, in some cases, be possible to avoid obstacles which are clearly visible but may be within the lateral limits noted in 2.2 d).

Note.— The procedures used in determining the accelerate-stop distance required, the take-off run required, the take-off distance required and the net take-off flight path are described in the Appendix to this example.

2.3 Conditions

For the purpose of 2.1 and 2.2, the performance is that corresponding to:

- a) the mass of the aeroplane at the start of take-off;
- b) an altitude equal to the elevation of the aerodrome;
- c) either the ambient temperature at the time of take-off, or a declared temperature giving an equivalent average level of performance;

and for the purpose of 2.2:

- d) the surface slope in the direction of take-off (landplanes);
- e) not more than 50 per cent of the reported wind component opposite to the direction of take-off, and not less than 150 per cent of the reported wind component in the direction of take-off. In certain cases of operation of seaplanes, it has been found necessary to take account of the reported wind component normal to the direction of take-off.

2.4 Power failure point

In applying 2.2 the power failure point chosen for establishing compliance with 2.2 a) is not nearer to the starting point than that used for establishing compliance with 2.2 b) and 2.2 c).

2.5 Turns

The net take-off flight path may include turns, provided that:

- a) the radius of steady turn assumed is not less than that scheduled for this purpose in the flight manual;
- b) if the planned change of direction of the take-off flight path exceeds 15 degrees, the clearance of the net take-off flight path above obstacles is at least 30 m (100 ft) during and after the turn, and the appropriate allowance, as prescribed in the flight manual, is made for the reduction in assumed gradient of climb during the turn;
- c) the distance D is measured along the intended track.

3. En route

3.1 All engines operating

At each point along the route and planned diversion therefrom, the all engines operating performance ceiling appropriate to the aeroplane mass at that point, taking into account the amount of fuel and oil expected to be consumed, is not less than the minimum altitude (see Chapter 4, 4.2.6) or, if greater, the planned altitude which it is intended to maintain with all engines operating, in order to ensure compliance with 3.2 and 3.3.

3.2 One engine inoperative

From each point along the route and planned diversions therefrom, it is possible in the event of one engine becoming inoperative to continue the flight to an en-route alternate aerodrome where a landing can be made in accordance with 4.2 and, on arrival at the aerodrome, the net gradient of climb is not less than zero at a height of 450 m (1 500 ft) above the elevation of the aerodrome.

3.3 Two engines inoperative

(applicable only to aeroplanes with four engines)

For each point along the route or planned diversions therefrom, at which the aeroplane is more than 90 minutes' flying time at all engines operating cruising speed from an en-route alternate aerodrome, the two engines inoperative net flight path is such that a height of at least 300 m (1 000 ft) above terrain can be maintained until arrival at such an aerodrome.

Note.— The net flight path is that attainable from the expected gradient of climb or descent diminished by 0.2 per cent.

3.4 Conditions

The ability to comply with 3.1, 3.2 and 3.3 is assessed:

- a) either on the basis of forecast temperatures, or on the basis of declared temperatures giving an equivalent average level of performance;
- b) on the forecast data on wind velocity versus altitude and locality assumed for the flight plan as a whole;
- c) in the case of 3.2 and 3.3, on the scheduled gradient of climb or gradient of descent after power failure appropriate to the mass and altitude at each point considered;

- d) on the basis that, if the aeroplane is expected to gain altitude at some point in the flight after power failure has occurred, a satisfactory positive net gradient of climb is available;
- e) in the case of 3.2 on the basis that the minimum altitude (see Chapter 4, 4.2.6), appropriate to each point between the place at which power failure is assumed to occur and the aerodrome at which it is intended to alight, is exceeded;
- f) in the case of 3.2, making reasonable allowance for indecision and navigational error in the event of engine failure at any point.

4. Landing

4.1 Mass

The calculated mass for the expected time of landing at the aerodrome of intended landing or any destination alternate aerodrome is not to exceed the maximum specified in the flight manual for the altitude and temperature at which the landing is to be made.

4.2 Landing distance required

The landing distance required at the aerodrome of the intended landing or at any alternate aerodrome, as determined from the flight manual, is not to exceed the landing distance available on:

- a) the most suitable landing surface for a landing in still air; and, if more severe,
- b) any other landing surface that may be required for landing because of expected wind conditions at the time of arrival.

4.3 Conditions

For the purpose of 4.2, the landing distance required is that corresponding to:

- a) the calculated mass of the aeroplane for the expected time of landing;
- b) an altitude equal to the elevation of the aerodrome;
- c) the expected temperature at which landing is to be made or a declared temperature giving an equivalent average level of performance;
- d) the surface slope in the direction of landing;
- e) for the purpose of 4.2 a), still air;
- f) for the purpose of 4.2 b), not more than 50 per cent of the expected wind component along the landing path and opposite to the direction of landing and not less than 150 per cent of the expected wind component in the direction of landing.

**APPENDIX TO EXAMPLE 2 ON AEROPLANE PERFORMANCE OPERATING LIMITATIONS —
PROCEDURES USED IN DETERMINING TAKE-OFF AND LANDING PERFORMANCE**

1. General

1.1 Unless otherwise stated, reference humidity and still air conditions are applied.

1.2 The performance of the aeroplane is determined in such a manner that the approved airworthiness limitations for the aeroplane and its systems are not exceeded.

1.3 The wing flap positions for showing compliance with the performance specifications are selected.

Note.— Alternative wing flap positions are made available, if so desired, in such a manner as to be consistent with acceptably simple operating techniques.

1.4 The position of the centre of gravity is selected within the permissible range so that the performance achieved in the configuration and power indicated in the specification under consideration is a minimum.

1.5 The performance of the aeroplane is determined in such a manner that under all conditions the approved limitations for the engine are not exceeded.

1.6 While certain configurations of cooling gills have been specified based upon maximum anticipated temperature, the use of other positions is acceptable provided that an equivalent level of safety is maintained.

1.7 The determined performance is so scheduled that it can serve directly in showing compliance with the aeroplane performance operating limitations.

2. Take-off

2.1 General

2.1.1 The following take-off data are determined for sea level pressure and temperature in the Standard Atmosphere, and reference humidity conditions, with the aeroplane at the corresponding maximum take-off mass for a level, smooth, dry and hard take-off surface (landplanes) and for smooth water of declared density (seaplanes):

- | | |
|--|------------------------------------|
| a) take-off safety speed and any other relevant speed; | } associated with items d), e), f) |
| b) power failure point; | |
| c) power failure point criterion, e.g. airspeed indicator reading; | |
| d) accelerate-stop distance required; | |
| e) take-off run required; | |
| f) take-off distance required; | |
| g) net take-off flight path; | |

- h) radius of a steady Rate 1 (180 degrees per minute) turn made at the airspeed used in establishing the net take-off flight path, and the corresponding reduction in gradient of climb in accordance with the conditions of 2.9.

2.1.2 The determination is also made over selected ranges of the following variables:

- a) aeroplane mass;
- b) pressure-altitude at the take-off surface;
- c) outside air temperature;
- d) steady wind velocity parallel to the direction of take-off;
- e) steady wind velocity normal to the direction of take-off (seaplanes);
- f) take-off surface slope over the take-off distance required (landplanes);
- g) water surface condition (seaplanes);
- h) density of water (seaplanes);
- i) strength of current (seaplanes);
- j) power failure point (subject to provisions of 2.4.3).

2.1.3 For seaplanes appropriate interpretations of the term landing gear, etc., are made to provide for the operation of retractable floats, if employed.

2.2 Take-off safety speed

2.2.1 The take-off safety speed is an airspeed (CAS) so selected that it is not less than:

- a) $1.20V_{s_1}$, for aeroplanes with two engines;
- b) $1.15V_{s_1}$, for aeroplanes having more than two engines;
- c) 1.10 times the minimum control speed, V_{MC} , established as prescribed in 2.3;
- d) the minimum speed prescribed in 2.9.7.6;

where V_{s_1} is appropriate to the take-off configuration.

Note.— See Example 1 for definition of V_{s_1} .

2.3 Minimum control speed

2.3.1 The minimum control speed is such that, when any one engine is made inoperative at that speed, it is possible to recover control of the aeroplane with the one engine still inoperative and to maintain the aeroplane in straight flight at that speed either with zero yaw or with a bank not in excess of 5 degrees.

2.3.2 From the time at which the engine is made inoperative to the time at which recovery is complete, exceptional skill, alertness, or strength, on the part of the pilot is not required to prevent any loss of altitude other than that implicit in the loss of performance or any change of heading in excess of 20 degrees, nor does the aeroplane assume any dangerous attitude.

2.3.3 It is demonstrated that to maintain the aeroplane in steady straight flight at this speed after recovery and before retrimming does not require a rudder control force exceeding 800 N and does not make it necessary for the flight crew to reduce the power of the remaining engines.

2.4 Power failure point

2.4.1 The power failure point is the point at which sudden complete loss of power from the engine, critical from the performance aspect in the case considered, is assumed to occur. If the airspeed corresponding to this point is less than the take-off safety speed, it is demonstrated that, in the event of sudden failure of the critical engine at all speeds down to the lowest speed corresponding with the power failure point, the aeroplane is controllable satisfactorily and that the take-off can be continued safely, using normal piloting skill, without:

- a) reducing the thrust of the remaining engines; and
- b) encountering characteristics which would result in unsatisfactory controllability on wet runways.

2.4.2 If the critical engine varies with the configuration, and this variation has a substantial effect on performance, either the critical engine is considered separately for each element concerned, or it is shown that the established performance provides for each possibility of single engine failure.

2.4.3 The power failure point is selected for each take-off distance required and take-off run required, and for each accelerate-stop distance required. The pilot is provided with a ready and reliable means of determining when the applicable power failure point has been reached.

2.5 Accelerate-stop distance required

2.5.1 The accelerate-stop distance required is the distance required to reach the power failure point from a standing start and, assuming the critical engine to fail suddenly at this point, to stop if a landplane, or to bring the aeroplane to a speed of approximately 9 km/h (5 kt) if a seaplane.

2.5.2 Use of braking means in addition to, or in lieu of, wheel brakes is permitted in determining this distance, provided that they are reliable and that the manner of their employment is such that consistent results can be expected under normal conditions of operation, and provided that exceptional skill is not required to control the aeroplane.

2.6 Take-off run required

The take-off run required is the greater of the following:

- 1.15 times the distance required with all engines operating to accelerate from a standing start to take-off safety speed;
- 1.0 times the distance required to accelerate from a standing start to take-off safety speed assuming the critical engine to fail at the power failure point.

2.7 Take-off distance required

2.7.1 The take-off distance required is the distance required to reach a height of:

10.7 m (35 ft), for aeroplanes with two engines,

15.2 m (50 ft), for aeroplanes with four engines,

above the take-off surface, with the critical engine failing at the power failure point.

2.7.2 The heights mentioned above are those which can be just cleared by the aeroplane when following the relevant flight path in an unbanked attitude with the landing gear extended.

Note.— Paragraph 2.8 and the corresponding operating requirements, by defining the point at which the net take-off flight path starts as the 10.7 m (35 ft) height point, ensure that the appropriate net clearances are achieved.

2.8 Net take-off flight path

2.8.1 The net take-off flight path is the one-engine-inoperative flight path which starts at a height of 10.7 m (35 ft) at the end of the take-off distance required and extends to a height of at least 450 m (1 500 ft) calculated in accordance with the conditions of 2.9, the expected gradient of climb being diminished at each point by a gradient equal to:

0.5 per cent, for aeroplanes with two engines,

0.8 per cent, for aeroplanes with four engines.

2.8.2 The expected performance with which the aeroplane is credited in the take-off wing flap, take-off power condition, is available at the selected take-off safety speed and is substantially available at 9 km/h (5 kt) below this speed.

2.8.3 In addition the effect of significant turns is scheduled as follows:

Radius. The radius of a steady Rate 1 (180 degrees per minute) turn in still air at the various true airspeeds corresponding to the take-off safety speeds for each wing-flap setting used in establishing the net take-off flight path below the 450 m (1 500 ft) height point, is scheduled.

Performance change. The approximate reduction in performance due to the above turns is scheduled and corresponds to a change in gradient of

$$\left[0.5 \left(\frac{V}{185.2} \right)^2 \right] \quad \% \text{ where } V \text{ is the true airspeed in km/h; and}$$

$$\left[0.5 \left(\frac{V}{100} \right)^2 \right] \quad \% \text{ where } V \text{ is the true airspeed in knots.}$$

2.9 Conditions

2.9.1 Air speed

2.9.1.1 In determining the take-off distance required, the selected take-off safety speed is attained before the end of the take-off distance required is reached.

2.9.1.2 In determining the net take-off flight path below a height of 120 m (400 ft), the selected take-off safety speed is maintained, i.e. no credit is taken for acceleration before this height is reached.

2.9.1.3 In determining the net take-off flight path above a height of 120 m (400 ft), the airspeed is not less than the selected take-off safety speed. If the aeroplane is accelerated after reaching a height of 120 m (400 ft) and before reaching a height of 450 m (1 500 ft), the acceleration is assumed to take place in level flight and to have a value equal to the true acceleration available diminished by an acceleration equivalent to a climb gradient equal to that specified in 2.8.1.

2.9.1.4 The net take-off flight path includes transition to the initial en-route configuration and airspeed. During all transition stages, the above provisions regarding acceleration are complied with.

2.9.2 Wing flaps

The wing flaps are in the same position (take-off position) throughout, except:

- a) that the flaps may be moved at heights above 120 m (400 ft), provided that the airspeed specifications of 2.9.1 are met and that the take-off safety speed applicable to subsequent elements is appropriate to the new flap position;
- b) the wing flaps may be moved before the earliest power failure point is reached, if this is established as a satisfactory normal procedure.

2.9.3 Landing gear

2.9.3.1 In establishing the accelerate-stop distance required and the take-off run required, the landing gear are extended throughout.

2.9.3.2 In establishing the take-off distance required, retraction of the landing gear is not initiated until the selected take-off safety speed has been reached, except that, when the selected take-off safety speed exceeds the minimum value prescribed in 2.2, retraction of the landing gear may be initiated when a speed greater than the minimum value prescribed in 2.2 has been reached.

2.9.3.3 In establishing the net take-off flight path, the retraction of the landing gear is assumed to have been initiated not earlier than the point prescribed in 2.9.3.2.

2.9.4 Cooling

For that part of the net take-off flight path before the 120 m (400 ft) height point, plus any transition element which starts at the 120 m (400 ft) height point, the cowl flap position is such that, starting the take-off at the maximum temperatures permitted for the start of take-off, the relevant maximum temperature limitations are not exceeded in the maximum anticipated air temperature conditions. For any subsequent part of the net take-off flight path, the cowl flap position and airspeed are such that the appropriate temperature limitations would not be exceeded in steady flight in the maximum anticipated air temperatures. The cowl flaps of all engines at the start of the take-off are as above, and the cowl flaps of the inoperative engine may be assumed to be closed upon reaching the end of the take-off distance required.

2.9.5 Engine conditions

2.9.5.1 From the starting point to the power failure point, all engines may operate at maximum take-off power conditions. The operative engines do not operate at maximum take-off power limitations for a period greater than that for which the use of maximum take-off power is permitted.

2.9.5.2 After the period for which the take-off power may be used, maximum continuous power limitations are not exceeded. The period for which maximum take-off power is used is assumed to begin at the start of the take-off run.

2.9.6 Propeller conditions

At the starting point, all propellers are set in the condition recommended for take-off. Propeller feathering or pitch coarsening is not initiated (unless it is by automatic or auto-selective means) before the end of the take-off distance required.

2.9.7 Technique

2.9.7.1 In that part of the net take-off flight path prior to the 120 m (400 ft) height point, no changes of configuration or power are made which have the effect of reducing the gradient of climb.

2.9.7.2 The aeroplane is not flown or assumed to be flown in a manner which would make the gradient of any part of the net take-off flight path negative.

2.9.7.3 The technique chosen for those elements of the flight path conducted in steady flight, which are not the subject of numerical climb specifications, are such that the net gradient of climb is not less than 0.5 per cent.

2.9.7.4 All information which it may be necessary to furnish to the pilot, if the aeroplane is to be flown in a manner consistent with the scheduled performance, is obtained and recorded.

2.9.7.5 The aeroplane is held on, or close to the ground until the point at which it is permissible to initiate landing gear retraction has been reached.

2.9.7.6 No attempt is made to leave the ground until a speed has been reached which is at least:

- 15 per cent above the minimum possible unstick speed with all engines operating;
- 7 per cent above the minimum possible unstick speed with the critical engine inoperative;

except that these unstick speed margins may be reduced to 10 per cent and 5 per cent, respectively, when the limitation is due to landing gear geometry and not to ground stalling characteristics.

Note.— Compliance with this specification is determined by attempting to leave the ground at progressively lower speeds (by normal use of the controls except that up-elevator is applied earlier and more coarsely than is normal) until it has been shown to be possible to leave the ground at a speed which complies with these specifications, and to complete the take-off. It is recognized that during the test manoeuvre, the usual margin of control associated with normal operating techniques and scheduled performance information will not be available.

2.10 Methods of derivation

2.10.1 General

The take-off field lengths required are determined from measurements of actual take-offs and ground runs. The net take-off flight path is determined by calculating each section separately on the basis of performance data obtained in steady flight.

2.10.2 Net take-off flight path

Credit is not taken for any change in configuration until that change is complete, unless more accurate data are available to substantiate a less conservative assumption; ground effect is ignored.

2.10.3 Take-off distance required

Satisfactory corrections for the vertical gradient of wind velocity are made.

3. Landing

3.1 General

The landing distance required is determined:

- a) for the following conditions:
 - 1) sea level;
 - 2) aeroplane mass equal to the maximum landing mass at sea level;
 - 3) level, smooth, dry and hard landing surfaces (landplanes);
 - 4) smooth water of declared density (seaplanes);
- b) over selected ranges of the following variables:
 - 1) atmospheric conditions, namely: altitude, or pressure-altitude and temperature;
 - 2) aeroplane mass;
 - 3) steady wind velocity parallel to the direction of landing;
 - 4) uniform landing surface slope (landplanes);
 - 5) nature of landing surface (landplanes);
 - 6) water surface condition (seaplanes);
 - 7) density of water (seaplanes);
 - 8) strength of current (seaplanes).

3.2 Landing distance required

The landing distance required is the measured horizontal distance between that point on the landing surface at which the aeroplane is brought to a complete stop or, for seaplanes, to a speed of approximately 9 km/h (5 kt) and that point on the landing surface which the aeroplane cleared by 15.2 m (50 ft) multiplied by a factor of 1/0.7.

Note.— Some States have found it necessary to use a factor of 1/0.6 instead of 1/0.7.

3.3 Landing technique

3.3.1 In determining the measured landing distance:

- a) immediately before reaching the 15.2 m (50 ft) height, a steady approach is maintained, landing gear fully extended, with an airspeed of at least $1.3V_{s_0}$;

Note.— See Example 1 for definition of V_{s_0} .

- b) the nose of the aeroplane is not depressed in flight nor the forward thrust increased by application of engine power after reaching the 15.2 m (50 ft) height;
- c) the power is not reduced in such a way that the power used for establishing compliance with the balked landing climb requirement would not be obtained within 5 seconds if selected at any point down to touch down;
- d) reverse pitch or reverse thrust are not used when establishing the landing distance using this method and field length factor. Ground fine pitch is used if the effective drag/weight ratio in the airborne part of the landing distance is not less satisfactory than that of conventional piston-engined aeroplane;

Note.— This does not mean that reverse pitch or reverse thrust, or use of ground fine pitch, are to be discouraged.

- e) the wing flap control is set in the landing position, and remains constant during the final approach, flare out and touch down, and on the landing surface at airspeeds above $0.9V_{s_0}$. When the aeroplane is on the landing surface and the airspeed has fallen to less than $0.9V_{s_0}$, change of the wing-flap-control setting is acceptable;
- f) the landing is made in a manner such that there is no excessive vertical acceleration, no excessive tendency to bounce, and no display of any other undesirable handling characteristics, and such that its repetition does not require either an exceptional degree of skill on the part of the pilot, or exceptionally favourable conditions;
- g) wheel brakes are not used in a manner such as to produce excessive wear of brakes or tires, and the operating pressures on the braking system are not in excess of those approved.

3.3.2 The gradient of the steady approach and the details of the technique used in determining the landing distance, together with such variations in the technique as are recommended for landing with the critical engine inoperative, and any appreciable variation in landing distance resulting therefrom, are entered in the flight manual.

ATTACHMENT D. GUIDANCE FOR OPERATIONS BY TURBINE-ENGINED AEROPLANES BEYOND 60 MINUTES TO AN EN-ROUTE ALTERNATE AERODROME INCLUDING EXTENDED DIVERSION TIME OPERATIONS (EDTO)

(Supplementary to Chapter 4, 4.7)

1. Introduction

1.1 The purpose of this Attachment is to provide guidance on the general provisions relating to operations by turbine-engined aeroplanes beyond 60 minutes' flying time to an en-route alternate aerodrome and extended diversion time operations contained in Chapter 4, 4.7. The guidance will also assist States in establishing a threshold time and approving the maximum diversion time for a given operator with a specific aeroplane type. The provisions in Chapter 4, 4.7, are divided into:

- a) the basic provisions that apply to all aeroplanes operating beyond 60 minutes to an en-route alternate aerodrome; and
- b) provisions to fly beyond a threshold time, and up to a maximum diversion time, approved by the State of the Operator, that may be different for each operator/aeroplane type combination.

This Attachment provides guidance on the means of achieving the required level of safety envisaged.

1.2 Similar to the threshold time, the maximum diversion time is the range (expressed in time) from a point on a route to an en-route alternate aerodrome up to which the State of the Operator will grant approval. When approving the operator's maximum diversion time, States will need to consider not only the capable range of the aircraft, taking into consideration any limitation of the aeroplane's type certificate, but also the operator's previous experience on similar aircraft types and routes.

1.3 The material in this Attachment is organized to address guidance on operations beyond 60 minutes to an en-route alternate aerodrome for all aeroplanes with turbine engines (Section 2) and guidance for extended diversion time operations (Section 3). The EDTO section is further divided into general provisions (Section 3.1), provisions that apply to aeroplanes with more than two engines (Section 3.2) and provisions that apply to aeroplanes with two engines (Section 3.3). The sections on aeroplanes with two engines and more than two engines are organized in exactly the same way. It should be noted that these sections may appear to be similar and thus repetitive; however there are requirement differences based on the aeroplane type. The reader should see Sections 2 and 3.1 and then either 3.2 for aeroplanes with more than two engines or 3.3 for aeroplanes with two engines.

2. Operations by aeroplanes with turbine engines beyond 60 minutes to an en-route alternate aerodrome

2.1 General

2.1.1 All provisions for operations by aeroplanes with turbine engines beyond 60 minutes to an en-route alternate aerodrome also apply to extended diversion time operations (EDTO). Figure D-1 illustrates generically the integration of operations beyond 60 minutes to an en-route alternate aerodrome and EDTO.

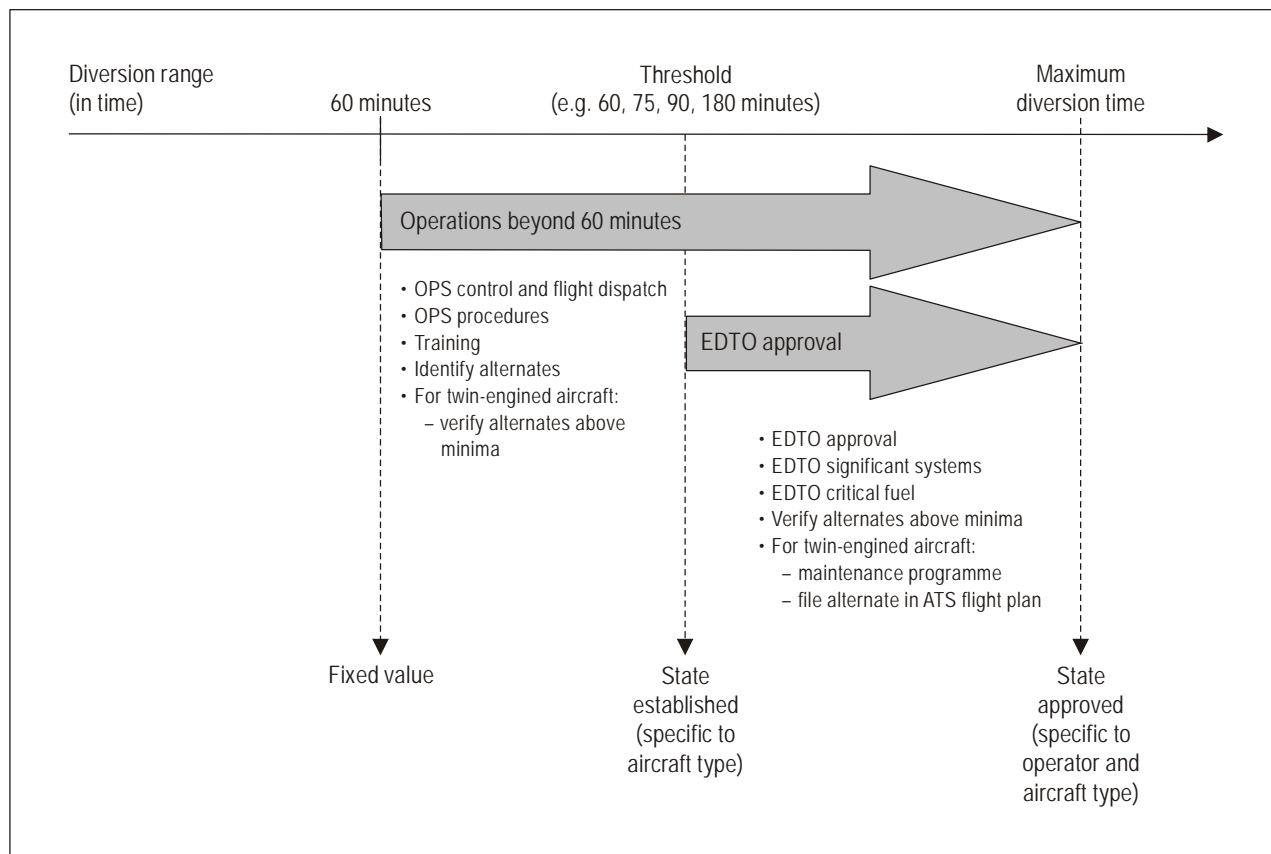

Figure D-1. Generic EDTO graphical representation

2.1.2 In applying the requirements for aeroplanes with turbine engines in Chapter 4, 4.7, it should be understood that:

- operational control refers to the exercise, by the operator, of responsibility for the initiation, continuation, termination or diversion of a flight;
- flight dispatch procedures refer to the method of control and supervision of flight operations. This does not imply a specific requirement for licensed flight dispatchers or a full flight following system;
- operating procedures refer to the specification of organization and methods established to exercise operational control and flight dispatch procedures in the appropriate manual(s) and should cover at least a description of responsibilities concerning the initiation, continuation, termination or diversion of each flight as well as the method of control and supervision of flight operations; and
- training programme refers to the training for pilots and flight operations officers/flight dispatchers in operations covered by this and following sections.

2.1.3 Aeroplanes with turbine engines operating beyond 60 minutes to an en-route alternate aerodrome are not required to have specific additional approval by the State of the Operator except if they engage in extended diversion time operations.

2.2 Conditions to be used when converting diversion times to distances

2.2.1 For the purpose of this guidance, an approved one-engine-inoperative (OEI) speed or approved all-engines-operative (AEO) speed is any speed within the certified flight envelope of the aeroplane.

2.2.2 Determination of the 60-minute distance — aeroplanes with two turbine engines

2.2.2.1 For determining whether a point on the route is beyond 60 minutes to an en-route alternate, the operator should select an approved OEI speed. The distance is calculated from the point of the diversion followed by cruise for 60 minutes, in ISA and still-air conditions, as shown in Figure D-2. For the purposes of computing distances, credit for driftdown may be taken.

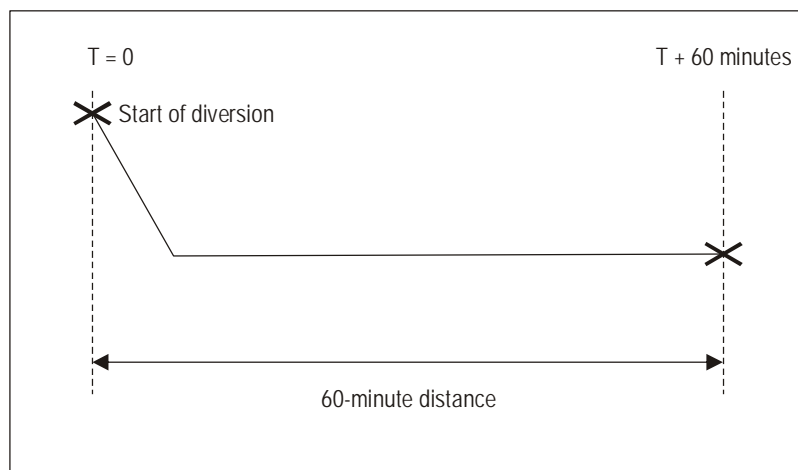

Figure D-2. Sixty-minute distance — aeroplanes with two turbine engines

2.2.3 Determination of the 60-minute distance — aeroplanes with more than two turbine engines

2.2.3.1 For determining whether a point on the route is beyond 60 minutes to an en-route alternate, the operator should select an approved AEO speed. The distance is calculated from the point of the diversion followed by cruise for 60 minutes, in ISA and still-air conditions, as shown in Figure D-3.

2.3 Training

2.3.1 Training programmes should ensure that the requirements of Chapter 9, 9.4.3.2, are complied with such as, but not limited to, route qualification, flight preparation, concept of extended diversion time operations and criteria for diversions.

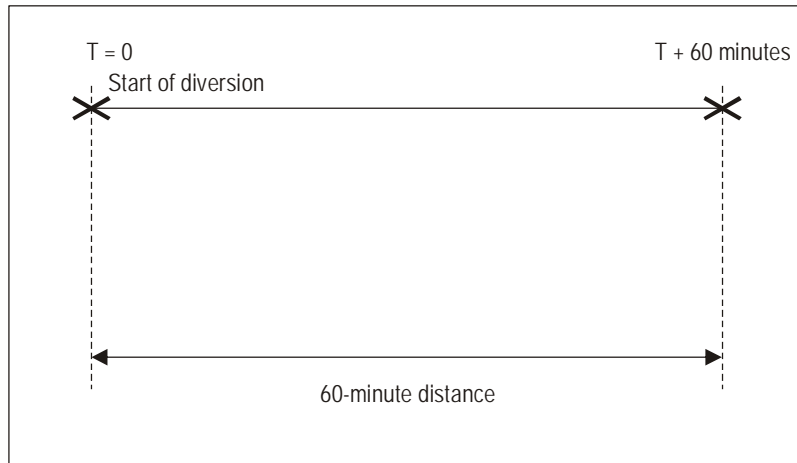

Figure D-3. Sixty-minute distance — aeroplanes with more than two turbine engines

2.4 Flight dispatch and operational requirements

2.4.1 In applying the general flight dispatch requirements of Chapter 4 particular attention should be paid to the conditions which might prevail any time that the operation is beyond 60 minutes to an en-route alternate aerodrome, e.g. systems degradation and reduced flight altitude. For compliance with the requirement of Chapter 4, 4.7, at least the following aspects should be considered:

- a) identify en-route alternate aerodromes;
- b) ensure that, prior to departure, the flight crew is provided with the most up-to-date information on the identified en-route alternate aerodromes, including operational status and meteorological conditions and, in flight, make available means for the flight crew to obtain the most up-to-date weather information;
- c) methods to enable two-way communications between the aeroplane and the operator's operational control centre;
- d) ensure that the operator has a means to monitor conditions along the planned route including the identified alternate aerodromes and ensure that procedures are in place so that the flight crew are advised of any situation that may affect the safety of flight;
- e) ensure that the intended route does not exceed the established aeroplane threshold time unless the operator is approved for EDTO operations;
- f) pre-flight system serviceability including the status of items in the minimum equipment list;
- g) communication and navigation facilities and capabilities;
- h) fuel requirements; and
- i) availability of relevant performance information for the identified en-route alternate aerodrome(s).

2.4.2 In addition, operations conducted by aeroplanes with two turbine engines require that, prior to departure and in flight, the meteorological conditions at identified en-route alternate aerodromes will be at or above the aerodrome operating minima required for the operation during the estimated time of use.

2.5 En-route alternate aerodromes

2.5.1 Aerodrome(s) to which an aircraft may proceed in the event that a diversion becomes necessary while en route, where the necessary services and facilities are available, where aircraft performance requirements can be met, and which are expected to be operational if required, need to be identified any time that the operation is beyond 60 minutes to an en-route alternate aerodrome.

Note.— En-route alternate aerodromes may also be the take-off and/or destination aerodromes.

3. Extended diversion time operations (EDTO) requirements

3.1 Basic concept

3.1.1 In addition to the provisions in Section 2, this section addresses the provisions that apply to operations by aeroplanes with two or more turbine engines where the diversion time to an en-route alternate aerodrome is greater than the threshold time established by the State of the Operator (extended diversion time operations).

3.1.2 EDTO significant systems

3.1.2.1 EDTO significant systems may be the aeroplane propulsion system and any other aeroplane systems whose failure or malfunctioning could adversely affect safety particular to an EDTO flight, or whose functioning is specifically important to continued safe flight and landing during an aeroplane EDTO diversion.

3.1.2.2 Many of the aeroplane systems that are essential for non-extended diversion time operations may need to be reconsidered to ensure that the redundancy level and/or reliability will be adequate to support the conduct of safe extended diversion time operations.

3.1.2.3 The maximum diversion time should not exceed the value of the EDTO significant system limitation(s), if any, for extended diversion time operations identified in the aeroplane flight manual, directly or by reference, reduced by an operational safety margin, commonly 15 minutes, specified by the State of the Operator.

3.1.2.4 The specific safety risk assessment to approve operations beyond the time limits of an EDTO significant time-limited system per the provisions in Chapter 4, 4.7.2.3.1, should be based on the safety risk management guidance contained in the *Safety Management Manual (SMM)* (Doc 9859). Hazards should be identified and safety risks assessed according to predicted probability and the severity of the consequences based on the worst foreseeable situation. When addressing the following components of the specific safety risk assessment it should be understood that:

- a) capabilities of the operator refer to the operator's quantifiable in-service experience, compliance record, aeroplane capability and overall operational reliability that:
 - 1) are sufficient to support operations beyond the time limits of an EDTO significant time-limited system;
 - 2) demonstrate the ability of the operator to monitor and respond to changes in a timely manner; and

- 3) there is an expectation that the operator's established processes, necessary for successful and reliable extended diversion time operations, can be successfully applied to such operations;
- b) overall reliability of the aeroplane refers to:
- 1) quantifiable standards of reliability taking into account the number of engines, aircraft EDTO significant systems and any other factors that may affect operations beyond the time limits of a particular EDTO significant time-limited system; and
 - 2) relevant data from the aeroplane manufacturer and data from the operator reliability programme used as a basis to determine overall reliability of the aeroplane and its EDTO significant systems;
- c) reliability of each time-limited system refers to quantifiable standards of design, testing and monitoring that ensure the reliability of each particular EDTO significant time-limited system;
- d) relevant information from the aeroplane manufacturer refers to technical data and characteristics of the aeroplane and worldwide fleet operational data provided by the manufacturer and used as a basis to determine overall reliability of the aeroplane and its EDTO significant systems; and
- e) specific mitigation measures refer to the safety risk management mitigation strategies, which have manufacturer concurrence, that ensure an equivalent level of safety is maintained. These specific mitigations shall be based on:
- 1) technical expertise (e.g. data, evidence) proving the operator's eligibility for an approval of operations beyond the time limit of the relevant EDTO significant system; and
 - 2) an assessment of relevant hazards, their probability and the severity of the consequences that may adversely impact the safety of the operation of an aeroplane operated beyond the limit of a particular EDTO significant time-limited system.

3.1.3 *Threshold time*

3.1.3.1 It should be understood that the threshold time established in accordance with Chapter 4, 4.7, is not an operating limit. It is a flight time to an en-route alternate aerodrome, which is established by the State of the Operator as being the EDTO threshold beyond which particular consideration should be given to the aeroplane capability as well as the operator's relevant operational experience, before granting an EDTO approval.

3.1.4 *Maximum diversion time*

3.1.4.1 It should be understood that the maximum diversion time approved in accordance with Chapter 4, 4.7, should take into consideration the most limiting EDTO significant system time limitation, if any, indicated in the aeroplane flight manual (directly or by reference) for a particular aeroplane type and the operator's operational and EDTO experience, if any, with the aeroplane type or, if relevant, with another aeroplane type or model.

3.2 EDTO for aeroplanes with more than two turbine engines

3.2.1 *General*

3.2.1.1 In addition to the provisions in Sections 2 and 3.1 of this Attachment, this section addresses the provisions that apply in particular to aeroplanes with more than two turbine engines (see Figure D-4).

Note.— EDTO may be referred to as ETOPS in some documents.

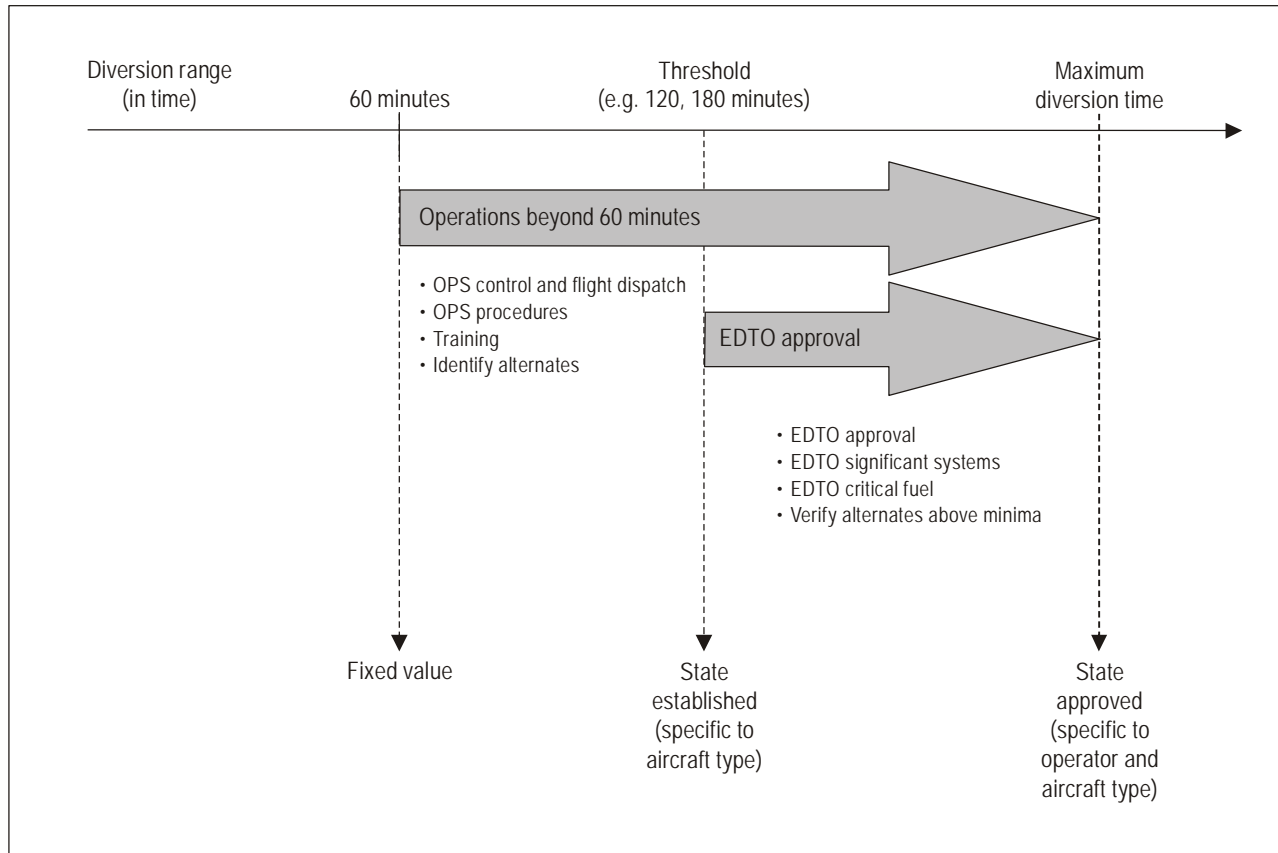

Figure D-4. Generic EDTO graphical representation for aeroplanes with more than two turbine engines

3.2.2 Operational and diversion planning principles

3.2.2.1 When planning or conducting extended diversion time operations, an operator and pilot-in-command should ensure that:

- the minimum equipment list, the communications and navigation facilities, fuel and oil supply, en-route alternate aerodromes and aeroplane performance are appropriately considered;
- if no more than one engine is shut down, the pilot-in-command may elect to continue beyond the nearest en-route alternate aerodrome (in terms of time) if the pilot-in-command determines that it is safe to do so. In making this decision the pilot-in-command should consider all relevant factors; and
- in the event of a single or multiple failure of an EDTO significant system or systems (excluding engine failure), the aircraft can proceed to and land at the nearest available en-route alternate aerodrome where a safe landing can be made unless it has been determined that no substantial degradation of safety will result from any decision made to continue the planned flight.

3.2.2.2 EDTO critical fuel

3.2.2.2.1 An aeroplane with more than two engines engaged in EDTO operations should carry enough fuel to fly to an en-route alternate aerodrome as described in 3.2.6. This EDTO critical fuel corresponds to the additional fuel that may be required to comply with Annex 6, Chapter 4, 4.3.6.3 f) 2).

3.2.2.2.2 The following should be considered, using the anticipated mass of the aeroplane, in determining the corresponding EDTO critical fuel:

- a) fuel sufficient to fly to an en-route alternate aerodrome, considering at the most critical point of the route, simultaneous engine failure and depressurization or depressurization alone, whichever is more limiting;
 - 1) the speed selected for the diversions (i.e. depressurization, combined or not with an engine failure) may be different from the approved AEO speed used to determine the EDTO threshold and maximum diversion distance (see 3.2.8);
- b) fuel to account for icing;
- c) fuel to account for errors in wind forecasting;
- d) fuel to account for holding an instrument approach and landing at the en-route alternate aerodrome;
- e) fuel to account for deterioration in cruise fuel-burn performance; and
- f) fuel to account for APU use (if required).

Note.— Guidance on EDTO critical fuel planning can be found in the Flight Planning and Fuel Management Manual (Doc 9976).

3.2.2.3 The following factors may be considered in determining if a landing at a given aerodrome is the more appropriate course of action:

- a) aeroplane configuration, mass, systems status and fuel remaining;
- b) wind and weather conditions en route at the diversion altitude, minimum altitudes en route and fuel consumption to the en-route alternate aerodrome;
- c) runways available, runway surface condition and weather, wind and terrain in the proximity of the en-route alternate aerodrome;
- d) instrument approaches and approach/runway lighting available and rescue and fire fighting services (RFFS) at the en-route alternate aerodrome;
- e) the pilot's familiarity with that aerodrome and information about that aerodrome provided to the pilot by the operator; and
- f) facilities for passenger and crew disembarkation and accommodation.

3.2.3 Threshold time

3.2.3.1 In establishing the appropriate threshold time and to maintain the required level of safety, it is necessary for States to consider that:

- a) the airworthiness certification of the aeroplane type does not restrict operations beyond the threshold time, taking into account the aeroplane system design and reliability aspects;
- b) specific flight dispatch requirements are met;
- c) necessary in-flight operational procedures are established; and
- d) the operator's previous experience on similar aircraft types and routes is satisfactory.

3.2.3.2 For determining whether a point on a route is beyond the EDTO threshold to an en-route alternate aerodrome, the operator should use the approved speed as described in 3.2.8.

3.2.4 *Maximum diversion time*

3.2.4.1 In approving the maximum diversion time, the State of the Operator should take into consideration the aeroplane's EDTO significant systems (e.g. limiting time limitation, if any, and relevant to that particular operation) for a particular aeroplane type and the operator's operational and EDTO experience with the aeroplane type or, if relevant, with another aeroplane type or model.

3.2.4.2 For determining the maximum diversion distance to an en-route alternate, the operator should use the approved speed as described in 3.2.8.

3.2.4.3 The operator's approved maximum diversion time should not exceed the most limiting EDTO significant system time limitation identified in the aeroplane flight manual, reduced by an operational safety margin, commonly 15 minutes, specified by the State of the Operator.

3.2.5 *EDTO significant systems*

3.2.5.1 In addition to the provisions in 3.1.1, this section addresses particular provisions for aeroplanes with more than two turbine engines.

3.2.5.2 *Consideration of time limitations*

3.2.5.2.1 For all operations beyond the EDTO threshold as determined by the State of the Operator, the operator should consider, at time of dispatch and as outlined below, the most limiting EDTO significant system time limitation, if any, indicated in the aeroplane flight manual (directly or by reference) and relevant to that particular operation.

3.2.5.2.2 The operator should check that from any point on the route, the maximum diversion time does not exceed the most limiting EDTO significant system time limitation, reduced by an operational safety margin, commonly 15 minutes, specified by the State of the Operator.

3.2.5.2.3 Not applicable. Considerations for the maximum diversion time subject to cargo fire suppression time limitations are considered part of the most limiting EDTO significant time limitations in 3.3.5.2.2.

3.2.5.2.4 For that purpose, the operator should consider the approved speed as described in 3.2.8.2 or consider adjusting that speed with forecast wind and temperature conditions for operations with longer threshold times (e.g. beyond 180 minutes) as determined by the State of the Operator.

3.2.6 *En-route alternate aerodromes*

3.2.6.1 In addition to the en-route alternate aerodrome provisions described in 2.5 the following apply:

- a) for route planning purposes, identified en-route alternate aerodromes, which could be used if necessary, need to be located at a distance within the maximum diversion time from the route; and
- b) in extended diversion time operations, before an aeroplane crosses its threshold time during flight, there should always be an en-route alternate aerodrome within the approved maximum diversion time whose conditions will be at or above the operator's established aerodrome operating minima for the operation during the estimated time of use.

If any conditions, such as weather below landing minima, are identified that would preclude a safe approach and landing at that aerodrome during the estimated time of use, an alternative course of action should be determined such as selecting another en-route alternate aerodrome within the operator's approved maximum diversion time.

Note.— *En route alternate aerodromes may also be the take-off and/or destination aerodromes.*

3.2.7 *Operational approval procedure*

3.2.7.1 In approving an operator with a particular aeroplane type for extended diversion time operations, the State of the Operator should establish an appropriate threshold time and maximum diversion time and, in addition to the requirements previously set forth in this Attachment, ensure that:

- a) specific operational approval is granted (by the State of the Operator);
- b) the operator's past experience and compliance record is satisfactory and the operator has established the processes necessary for successful and reliable extended diversion time operations and shown that such processes can be successfully applied throughout such operations;
- c) the operator's procedures are acceptable based on certified aeroplane capability and adequate to address continued safe operation in the event of degraded aeroplane systems;
- d) the operator's crew training programme is adequate for the proposed operation;
- e) documentation accompanying the authorization covers all relevant aspects; and
- f) it has been shown (e.g. during the EDTO certification of the aeroplane) that the flight can continue to a safe landing under the anticipated degraded operating conditions which would arise from:
 - 1) the most limiting EDTO significant system time limitation, if any, for extended diversion time operations identified in the aeroplane flight manual, directly or by reference; or
 - 2) any other condition which the State of the Operator considers to be equivalent in airworthiness and performance risk.

3.2.8 *Conditions to be used when converting diversion times to distances for the determination of the geographical area beyond threshold and within maximum diversion distances*

3.2.8.1 For the purpose of this guidance, an approved AEO speed is any all-engines-operative speed within the certified flight envelope of the aeroplane.

Note.— *See 3.2.5.2.2 for operational considerations.*

3.2.8.2 When applying for EDTO an operator should identify, and the State of the Operator should approve, the AEO speed(s), considering ISA and still-air conditions, that will be used to calculate the threshold and maximum diversion distances. The speed that will be used to calculate the maximum diversion distance may be different from the speed used to determine the 60-minute and EDTO thresholds.

3.2.8.3 Determination of the EDTO threshold

3.2.8.3.1 For determining whether a point on the route is beyond the EDTO threshold to an en-route alternate, the operator should use the approved speed (see 3.2.8.1 and 3.2.8.2). The distance is calculated from the point of the diversion followed by cruise for the threshold time as determined by the State of the Operator and shown in Figure D-5.

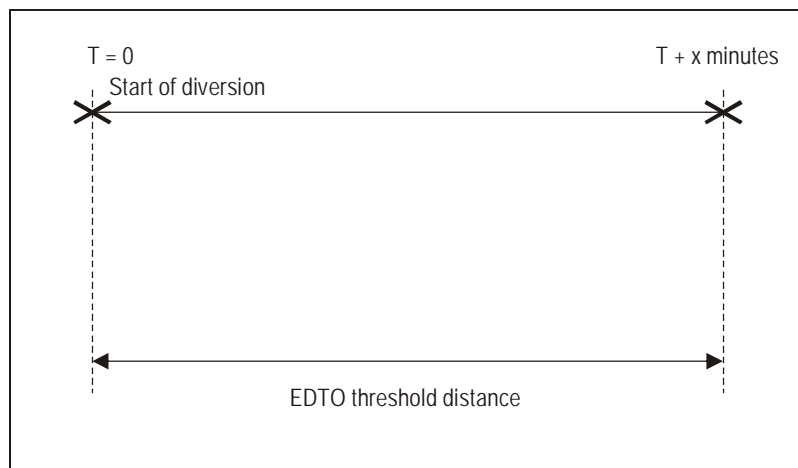

Figure D-5. Threshold distance — aeroplanes with more than two turbine engines

3.2.8.4 Determination of the maximum diversion time distance

3.2.8.4.1 For determining the maximum diversion time distance to an en-route alternate, the operator should use the approved speed (see 3.2.8.1 and 3.2.8.2). The distance is calculated from the point of the diversion followed by cruise for the maximum diversion time as approved by the State of the Operator and shown in Figure D-6.

3.2.9 *Airworthiness certification requirements for extended diversion time operations beyond the threshold time*

3.2.9.1 Not applicable. There are no additional EDTO airworthiness certification requirements for aeroplanes with more than two engines.

3.2.10 *Maintaining operational approval*

3.2.10.1 In order to maintain the required level of safety on routes where these aeroplanes are permitted to operate beyond the established threshold time, it is necessary that:

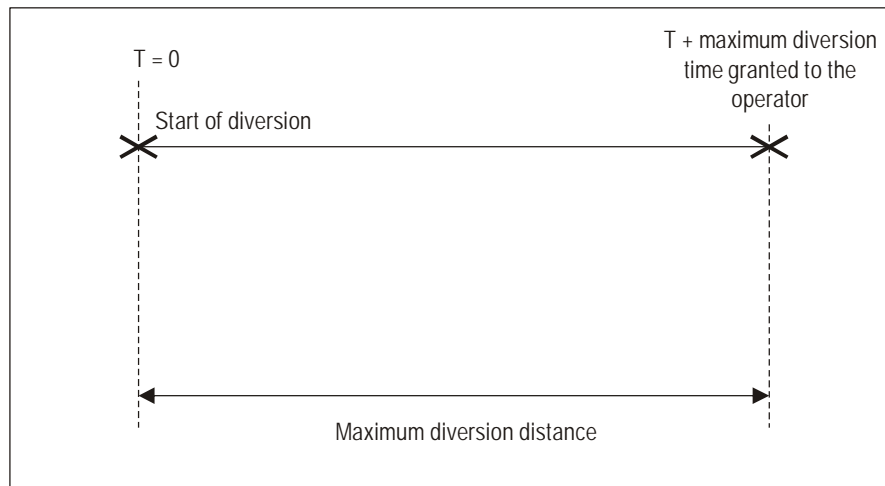

Figure D-6. Maximum diversion distance — aeroplanes with more than two turbine engines

- a) specific flight dispatch requirements are met;
- b) the necessary in-flight operational procedures are established; and
- c) specific operational approval is granted by the State of the Operator.

3.2.11 *Airworthiness modifications and maintenance programme requirements*

3.2.11.1 Not applicable. There are no additional EDTO airworthiness or maintenance requirements for aeroplanes with more than two engines.

3.2.12 *Examples*

3.2.12.1 In establishing the appropriate threshold and approved maximum diversion time for an operator with a particular aeroplane type, the State of the Operator should consider, but not be limited to, the following: the airworthiness certification of the aeroplane, the operator's experience in conducting operations beyond the 60-minute threshold, flight deck crew experience in conducting such operations, the maturity of that operator's flight dispatch system, the communication capability with the operator's operational control centre (ACARS, SATCOM, HF, etc.), the robustness of both the operator's standard operating procedures and the familiarity of the crews with those procedures, the maturity of the operator's safety management system, the crew training programme and the reliability of the propulsion system. The following examples are based on these considerations and are taken from actual State requirements:

- a) *State A*: State A has established the threshold time at 180 minutes based on the capability of the operator and the aeroplane type for an aeroplane with more than two engines and has approved a maximum diversion time of 240 minutes. That operator will need to have specific approval to be further than 180 minutes to an en-route alternate aerodrome (AEO speed in ISA and still-air conditions), remain within 240 minutes to an en-route alternate aerodrome and meet the requirements in Chapter 4, 4.7.1 to 4.7.2.4.

If that operator, with the particular aeroplane type, plans a route within the threshold time established by the State of the Operator (in the above example this is 180 minutes) to an en-route alternate aerodrome, that operator would not require any additional approval from the State of the Operator and would only need to comply with the requirements in Chapter 4, 4.7.1, if the operation is conducted beyond 60 minutes from an en-route alternate aerodrome.

- b) *State B*: The CAA is approached by an operator who is in the process of expansion, having acquired aeroplanes with more than two engines capable of EDTO. The operator submits an application to amend its AOC to include this new aeroplane type on newly granted routes. These routes take the flight beyond 60 minutes to an en-route alternate, thus requiring the establishment of a threshold time and approval of a maximum diversion time. Taking into account:
- 1) that the operator has not had previous experience with the routes and area of operation;
 - 2) the new aeroplane type;
 - 3) the inexperience of the company and its flight operations/operations control department at planning and dispatching such flights; and
 - 4) the new operating procedures to be established,

State B determines that the threshold time for the operator should be limited to 120 minutes and approves a maximum diversion time of 180 minutes.

As the operator gains experience with the operation and the procedures over time, the State may amend the initially established threshold time and approved maximum diversion time.

3.3 EDTO for aeroplanes with two turbine engines

3.3.1 General

3.3.1.1 In addition to the provisions in Sections 2 and 3.1, this section addresses the provisions that apply in particular to aeroplanes with two turbine engines (see Figure D-7).

3.3.1.2 EDTO provisions for aeroplanes with two turbine engines do not differ from the previous provisions for extended range operations by aeroplanes with two turbine engines (ETOPS). Therefore, EDTO may be referred to as ETOPS in some documents.

3.3.2 Operational and diversion planning principles

3.3.2.1 When planning or conducting extended diversion time operations, an operator and pilot-in-command should normally ensure that:

- a) the minimum equipment list, the communications and navigation facilities, fuel and oil supply, en-route alternate aerodromes or aeroplane performance are appropriately considered;
- b) in the event of an aeroplane engine shutdown, the aircraft can proceed to and land at the nearest (in terms of the least flying time) en-route alternate aerodrome where a safe landing can be made; and
- c) in the event of a single or multiple failure of an EDTO significant system or systems (excluding engine failure), the aircraft can proceed to and land at the nearest available en-route alternate aerodrome where a safe landing can be made unless it has been determined that no substantial degradation of safety will result from any decision made to continue the planned flight.

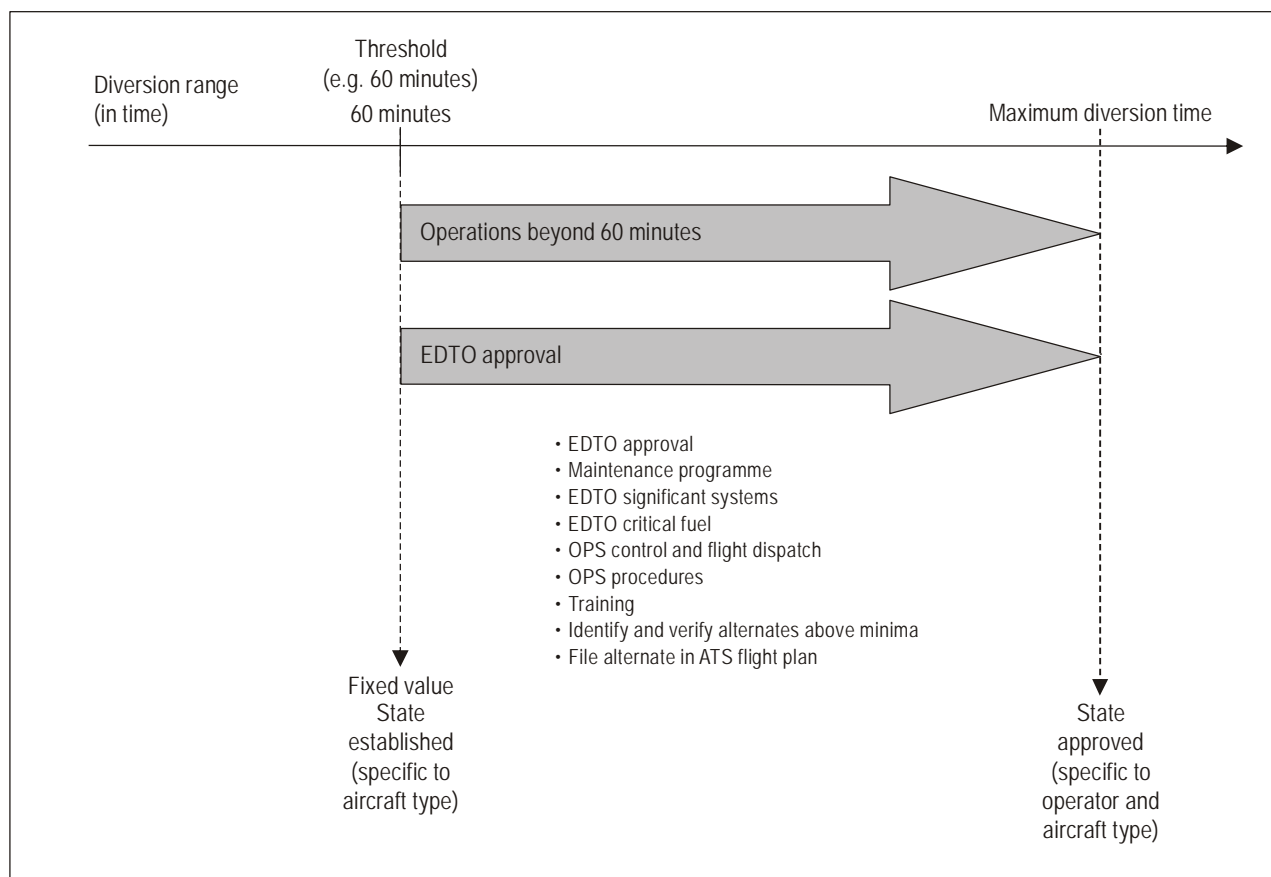

Figure D-7. Generic EDTO graphical representation for aeroplanes with two turbine engines

3.3.2.2 EDTO critical fuel

3.3.2.2.1 An aeroplane with two engines engaged in EDTO operations should carry enough fuel to fly to an en-route alternate aerodrome as described in 3.3.6. This EDTO critical fuel corresponds to the additional fuel that may be required to comply with Annex 6, Chapter 4, 4.3.6.3 f) 2).

3.3.2.2.2 The following should be considered, using the anticipated mass of the aeroplane, in determining the corresponding EDTO critical fuel:

- a) fuel sufficient to fly to an en-route alternate aerodrome, considering at the most critical point of the route, failure of one engine or simultaneous engine failure and depressurization or depressurization alone, whichever is more limiting;
 - 1) the speed selected for the all-engines-operative diversion (i.e. depressurization alone) may be different from the approved OEI speed used to determine the EDTO threshold and maximum diversion distance (see 3.3.8);
 - 2) the speed selected for the OEI diversions (i.e. engine failure alone and combined engine failure and depressurization) should be the approved OEI speed used to determine the EDTO threshold and maximum diversion distance (see 3.3.8);

- b) fuel to account for icing;
- c) fuel to account for errors in wind forecasting;
- d) fuel to account for holding an instrument approach and landing at the en-route alternate aerodrome;
- e) fuel to account for deterioration in cruise fuel-burn performance; and
- f) fuel to account for APU use (if required).

Note.— *Guidance on EDTO critical fuel planning can be found in the Flight Planning and Fuel Management Manual (Doc 9976).*

3.3.2.3 The following factors may be considered in determining if a landing at a given aerodrome is the more appropriate course of action:

- a) aeroplane configuration, mass, systems status and fuel remaining;
- b) wind and weather conditions en route at the diversion altitude, minimum altitudes en route and fuel consumption to the en-route alternate aerodrome;
- c) runways available, runway surface condition and weather, wind and terrain in the proximity of the en-route alternate aerodrome;
- d) instrument approaches and approach/runway lighting available and rescue and fire fighting services (RFFS) at the en-route alternate aerodrome;
- e) the pilot's familiarity with that aerodrome and information about that aerodrome provided to the pilot by the operator; and
- f) facilities for passenger and crew disembarkation and accommodation.

3.3.3 *Threshold time*

3.3.3.1 In establishing the appropriate threshold time and to maintain the required level of safety, it is necessary for States to consider that:

- a) the airworthiness certification of the aeroplane type specifically permits operations beyond the threshold time, taking into account the aeroplane system design and reliability aspects;
- b) the reliability of the propulsion system is such that the risk of double engine failure from independent causes is extremely remote;
- c) any necessary special maintenance requirements are fulfilled;
- d) specific flight dispatch requirements are met;
- e) necessary in-flight operational procedures are established; and
- f) the operator's previous experience on similar aircraft types and routes is satisfactory.

3.3.3.2 For determining whether a point on a route is beyond the EDTO threshold to an en-route alternate aerodrome, the operator should use the approved speed as described in 3.3.8.

3.3.4 Maximum diversion time

3.3.4.1 In approving the maximum diversion time, the State of the Operator should take into consideration the EDTO certified capability of the aeroplane, the aeroplane's EDTO significant systems (e.g. limiting time limitation, if any, and relevant to that particular operation) for a particular aeroplane type and the operator's operational and EDTO experience with the aeroplane type or, if relevant, with another aeroplane type or model.

3.3.4.2 For determining the maximum diversion distance to an en-route alternate, the operator should use the approved speed as described in 3.3.8.

3.3.4.3 The operator's approved maximum diversion time should not exceed the EDTO certified capability of the aeroplane or the most limiting EDTO significant system time limitation identified in the aeroplane flight manual, reduced by an operational safety margin, commonly 15 minutes, specified by the State of the Operator.

3.3.5 EDTO significant systems

3.3.5.1 In addition to the provisions in 3.1.1, this section addresses particular provisions for aeroplanes with two turbine engines.

3.3.5.1.1 The reliability of the propulsion system for the aeroplane/engine combination being certified is such that the risk of double engine failure from independent causes is assessed as provided for in the *Airworthiness Manual* (Doc 9760) and found acceptable to support the diversion time being approved.

Note.— EDTO may be referred to as ETOPS in some documents.

3.3.5.2 Consideration of time limitations

3.3.5.2.1 For all operations beyond the EDTO threshold, as determined by the State of the Operator, the operator should consider, at time of dispatch and as outlined below, the EDTO certified capability of the aeroplane and the most limiting EDTO significant system time limitation, if any, indicated in the aeroplane flight manual (directly or by reference) and relevant to that particular operation.

3.3.5.2.2 The operator should check that from any point on the route, the maximum diversion time at the approved speed as described in 3.3.8.2 does not exceed the most limiting EDTO significant system time limitation, other than the cargo fire suppression system, reduced by an operational safety margin, commonly 15 minutes, specified by the State of the Operator.

3.3.5.2.3 The operator should check that from any point on the route, the maximum diversion time at all-engines operating cruise speed, considering ISA and still-air conditions, does not exceed the cargo fire suppression system time limitation, reduced by an operational safety margin, commonly 15 minutes, specified by the State of the Operator.

3.3.5.2.4 The operator should consider the approved speed as described in 3.3.5.2.2 and 3.3.5.2.3 or consider adjusting that speed with forecast wind and temperature conditions for operations with longer threshold times (e.g. beyond 180 minutes) as determined by the State of the Operator.

3.3.6 En-route alternate aerodromes

3.3.6.1 In addition to the en-route alternate aerodrome provisions described in 2.5, the following apply:

- a) for route planning purposes, identified en-route alternate aerodromes, which could be used if necessary, need to be located at a distance within the maximum diversion time from the route; and

- b) in extended diversion time operations, before an aeroplane crosses its threshold time during flight, there should always be an en-route alternate aerodrome within the approved maximum diversion time whose conditions will be at or above the operator's established aerodrome operating minima for the operation during the estimated time of use.

If any conditions, such as weather below landing minima, are identified that would preclude a safe approach and landing at that aerodrome during the estimated time of use, an alternative course of action should be determined such as selecting another en-route alternate aerodrome within the operator's approved maximum diversion time.

3.3.6.2 During flight preparation and throughout the flight the most up-to-date information on the identified en-route alternate aerodromes, including operational status and meteorological conditions, should be provided to the flight crew.

Note.— *En route alternate aerodromes may also be the take-off and/or destination aerodromes.*

3.3.7 Operational approval procedure

3.3.7.1 In approving an operator with a particular aeroplane type for extended diversion time operations, the State of the Operator should establish an appropriate threshold time and approve a maximum diversion time and, in addition to the requirements previously set forth in this Attachment, ensure that:

- a) specific operational approval is granted (by the State of the Operator);
- b) the operator's past experience and compliance record is satisfactory and the operator has established the processes necessary for successful and reliable extended diversion time operations and shown that such processes can be successfully applied throughout such operations;
- c) the operator's procedures are acceptable based on certified aeroplane capability and adequate to address continued safe operation in the event of degraded aeroplane systems;
- d) the operator's crew training programme is adequate for the proposed operation;
- e) documentation accompanying the authorization covers all relevant aspects; and
- f) it has been shown (e.g. during the EDTO certification of the aeroplane) that the flight can continue to a safe landing under the anticipated degraded operating conditions which would arise from:
 - 1) the most limiting EDTO significant system time limitation, if any, for extended diversion time operations identified in the aeroplane flight manual, directly or by reference; or
 - 2) total loss of engine-generated electric power; or
 - 3) total loss of thrust from one engine; or
 - 4) any other condition which the State of the Operator considers to be equivalent in airworthiness and performance risk.

3.3.8 Conditions to be used when converting diversion times to distances for the determination of the geographical area beyond threshold and within maximum diversion distances

3.3.8.1 For the purpose of this guidance, an approved OEI speed is any one-engine-inoperative speed within the certified flight envelope of the aeroplane.

Note.— *See 3.3.5.2.2 for operational considerations.*

3.3.8.2 When applying for EDTO an operator should identify, and the State of the Operator should approve, the OEI speed(s), considering ISA and still-air conditions, that will be used to calculate the threshold and maximum diversion distances. The identified speed that will be used to calculate the maximum diversion distance should be the same one used to determine fuel reserves for OEI diversions. This speed may be different from the speed used to determine the 60-minute and EDTO thresholds.

3.3.8.3 Determination of the EDTO threshold

3.3.8.3.1 For determining whether a point on the route is beyond the EDTO threshold to an en-route alternate, the operator should use the approved speed (see 3.3.8.1 and 3.3.8.2). The distance is calculated from the point of the diversion followed by cruise for the threshold time as determined by the State of the Operator and shown in Figure D-8. For the purposes of computing distances, credit for driftdown may be taken.

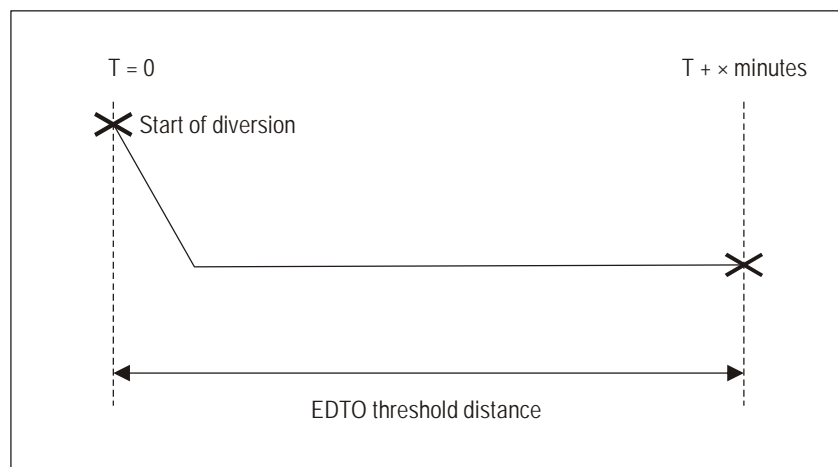

Figure D-8. Threshold distance — aeroplanes with two turbine engines

3.3.8.4 Determination of the maximum diversion time distance

3.3.8.4.1 For determining the maximum diversion time distance to an en-route alternate, the operator should use the approved speed (see 3.3.8.1 and 3.3.8.2). The distance is calculated from the point of the diversion followed by cruise for the maximum diversion time as approved by the State of the Operator and shown in Figure D-9. For the purposes of computing distances, credit for driftdown may be taken.

3.3.9 *Airworthiness certification requirements for extended diversion time operations beyond the threshold time*

3.3.9.1 During the airworthiness certification procedure for an aeroplane type intended for extended diversion time operations, special attention should be paid to ensure that the required level of safety will be maintained under conditions which may be encountered during such operations, e.g. flight for extended periods following failure of an engine and/or the

aeroplane's EDTO significant systems. Information or procedures specifically related to extended diversion time operations should be incorporated into the aeroplane flight manual, the maintenance manual, the EDTO configuration, maintenance and procedure (CMP) document or other appropriate document.

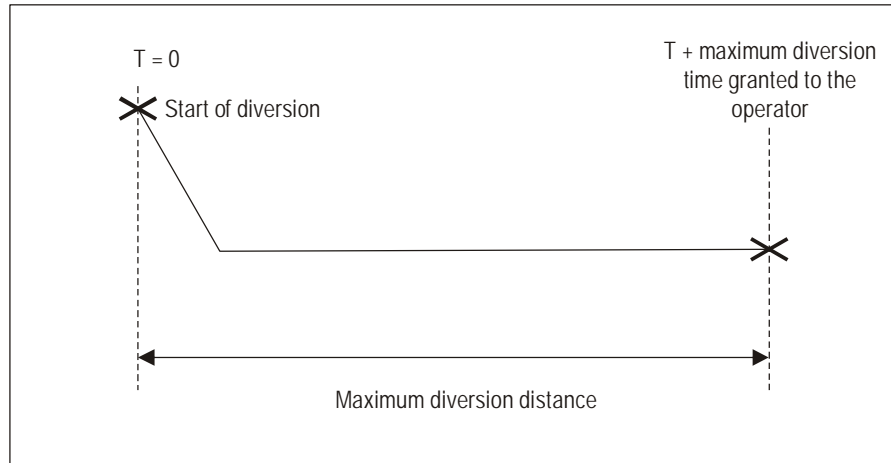

Figure D-9. Maximum diversion distance — aeroplanes with two turbine engines

3.3.9.2 Aeroplane manufacturers should supply data specifying the aeroplane's EDTO significant systems and, where appropriate, any time-limiting factors associated with those systems.

Note 1.— Criteria on aeroplane system performance and reliability for extended diversion time operations are contained in the Airworthiness Manual (Doc 9760).

Note 2.— EDTO may be referred to as ETOPS in some documents.

3.3.10 Maintaining operational approval

3.3.10.1 In order to maintain the required level of safety on routes where these aeroplanes are permitted to operate beyond the established threshold time, it is necessary that:

- a) the airworthiness certification of the aeroplane type specifically permits operations beyond the threshold time, taking into account the aeroplane's system design and reliability aspects;
- b) the reliability of the propulsion system is such that the risk of double engine failure from independent causes is extremely remote, assessed as provided for in the *Airworthiness Manual* (Doc 9760) and found acceptable to support the diversion time being approved;
- c) any special maintenance requirements are fulfilled;
- d) specific flight dispatch requirements are met;
- e) the necessary in-flight operational procedures are established; and
- f) specific operational approval is granted by the State of the Operator.

Note 1.— The airworthiness considerations applicable to extended diversion time operations are provided in the Airworthiness Manual (Doc 9760), Part IV, Chapter 2.

Note 2.— EDTO may be referred to as ETOPS in some documents.

3.3.11 Airworthiness modifications and maintenance programme requirements

3.3.11.1 Each operator's maintenance programme should ensure that:

- a) the titles and numbers of all airworthiness modifications, additions and changes which were made to qualify aeroplane systems for extended diversion time operations are provided to the State of Registry and, where applicable, to the State of the Operator;
- b) any changes to maintenance and training procedures, practices or limitations established in the qualification for extended diversion time operations are submitted to the State of the Operator and, where applicable, to the State of Registry before such changes are adopted;
- c) a reliability monitoring and reporting programme is developed and implemented prior to approval and continued after approval;
- d) prompt implementation of required modifications and inspections which could affect propulsion system reliability is undertaken;
- e) procedures are established which prevent an aeroplane from being dispatched for an extended diversion time operation after engine shutdown or EDTO significant system failure on a previous flight until the cause of such failure has been positively identified and the necessary corrective action has been completed. Confirmation that such corrective action has been effective may, in some cases, require the successful completion of a subsequent flight prior to dispatch on an extended diversion time operation;
- f) a procedure is established to ensure that the airborne equipment will continue to be maintained at the level of performance and reliability required for extended diversion time operations; and
- g) a procedure is established to minimize scheduled or unscheduled maintenance during the same maintenance visit on more than one parallel or similar EDTO significant system. Minimization can be accomplished by staggering maintenance tasks, performing and/or supervising maintenance by a different technician, or verifying maintenance correction actions prior to the aeroplane entering an EDTO threshold.

Note.— The maintenance considerations applicable to extended diversion time operations are provided in the Airworthiness Manual (Doc 9760).

3.3.12 Examples

3.3.12.1 In establishing the appropriate threshold and approved maximum diversion time for an operator with a particular aeroplane type, the State of the Operator should consider, but not be limited to, the following: the airworthiness certification of the aeroplane, the operator's experience in conducting operations beyond the 60-minute threshold, flight deck crew experience in conducting such operations, the maturity of that operator's flight dispatch system, the communication capability with the operator's operational control centre (ACARS, SATCOM, HF, etc.), the robustness of both the operator's standard operating procedures and the familiarity of the crews with those procedures, the maturity of the operator's safety management system, the crew training programme and the reliability of the propulsion system. The following examples are based on these considerations and are taken from actual State requirements:

- a) *State A*: State A has established the threshold time at 60 minutes based on the capability of the operator and the aeroplane type for a twin-engined aeroplane and has approved a maximum diversion time of 180 minutes. That operator will need to have specific approval to be further than 60 minutes to an en-route alternate aerodrome (calculated in ISA and still-air conditions at the one-engine-inoperative cruise speed), remain within 180 minutes to an en-route alternate aerodrome and meet the requirements in Chapter 4, 4.7.1 to 4.7.2.6.

If that operator, with the particular aeroplane type, plans a route within the threshold time established by the State of the Operator (in the above example this is 60 minutes) to an en-route alternate aerodrome, that operator, by definition, would not be conducting an extended diversion time operation and thus would not need to meet any of the provisions in Chapter 4, 4.7.

- b) *State B*: State B has established the threshold time at 90 minutes based on the capability of the operator and the aeroplane type for a twin-engined aeroplane and has approved a maximum diversion time of 180 minutes. That operator will need to have specific approval to be further than 90 minutes to an en-route alternate aerodrome (calculated in ISA and still-air conditions at the one-engine-inoperative cruise speed), remain within 180 minutes to an en-route alternate aerodrome and meet the requirements in Chapter 4, 4.7.1 to 4.7.2.6.

If that operator, with the particular aeroplane type, plans a route within the threshold time established by the State of the Operator (in the above example this is 90 minutes) to an en-route alternate aerodrome, that operator would not require any additional approval from the State of the Operator and would need only to comply with the requirements in Chapter 4, 4.7.1, and in particular 4.7.1.1 b).

- c) *The same State B*: The same State B is approached by an operator who is in the process of expansion, having acquired twin-engined aeroplanes capable of EDTO. The operator submits an application to amend its AOC to include this new aeroplane type on newly granted routes. These routes take the flight beyond 60 minutes to an en-route alternate, thus requiring the establishment of a threshold time and approval of a maximum diversion time. Taking into account:
- 1) that the operator has not had previous experience with the routes and area of operation;
 - 2) the new aeroplane type;
 - 3) the inexperience of the company and its flight operations/operations control department at planning and dispatching such flights; and
 - 4) the new operating procedures to be established,

State B determines that the threshold time for this operator should be limited to 60 minutes and approves a maximum diversion time of 120 minutes.

As this operator gains experience with the operation and the procedures over time, the State may amend the initially established threshold time and approved maximum diversion time.

ATTACHMENT E. AIR OPERATOR CERTIFICATION AND VALIDATION

Supplementary to Chapter 4, 4.2.1

1. Purpose and scope

1.1 Introduction

The purpose of this Attachment is to provide guidance concerning actions required by States in connection with the operator certification requirements in Chapter 4, 4.2.1, particularly the means of accomplishing and recording those actions.

1.2 Prior certification required

In accordance with Standard 4.2.1.3, the issuance of an air operator certificate (AOC) is “dependent upon the operator demonstrating” to the State that its organization, training policy and programmes, flight operations, ground handling and maintenance arrangements are adequate considering the nature and extent of the operations to be conducted. The certification process involves the State’s evaluation of each operator and a determination that the operator is capable of conducting safe operations before initial issuance of an AOC or the addition of any subsequent authorizations to an AOC.

1.3 Standard certification practices

The State of the Operator is required by Standard 4.2.1.8 to establish a certification system to ensure compliance with the required standards for the type of operation to be conducted. Several States have developed policies and procedures to comply with this certification requirement as industry capabilities evolve. While those States did not develop their certification practices in coordination with each other, their practices are remarkably similar and consistent in their requirements. The effectiveness of their practices has been validated over many years, resulting in improved safety records of operators throughout the world. Many of these certification practices have been incorporated by reference in ICAO provisions.

2. Required technical safety evaluations

2.1 Approval and acceptance actions

2.1.1 The certification and continued surveillance of an air operator includes actions taken by a State on matters submitted for its review. The actions can be categorized as approvals or acceptances depending on the nature of the response by the State to the matter submitted for its review.

2.1.2 An approval is an active response by the State to a matter submitted for its review. An approval constitutes a finding or determination of compliance with the applicable standards. An approval will be evidenced by the signature of the approving official, the issuance of a document or certificate, or some other formal action taken by the State.

2.1.3 An acceptance does not necessarily require an active response by the State to a matter submitted for its review. A State may accept a matter submitted to it for review as being in compliance with the applicable standards if the State does not specifically reject all or a portion of the matter under review, usually after some defined period of time after submission.

2.1.4 The phrase “approved by the State” or similar phrases using the word “approval” are frequently used in Annex 6, Part I. Provisions indicating a review and implying approval or at least “acceptance” by the State occur even more frequently in Annex 6, Part I. In addition to these specific phrases, Annex 6, Part I, contains numerous references to requirements which would, as a minimum, create the need for at least a technical review by the State. This Attachment groups and outlines those specific Standards and Recommended Practices for ease of use by States.

2.1.5 The State should make or arrange for a technical safety evaluation before issuing the approval or acceptance. The evaluation should:

- a) be accomplished by a person with specific qualifications to make such a technical evaluation;
- b) be in accordance with written, standardized methodology; and
- c) where necessary to safety, include a practical demonstration of the air operator’s actual ability to conduct such an operation.

2.2 Demonstrations before issuance of some approvals

2.2.1 Standard 4.2.1.3 obligates the State of the Operator, prior to certification of an operator, to require sufficient demonstrations by the operator to enable the State to evaluate the adequacy of the operator’s organization, method of control and supervision of flight operations, ground handling and maintenance arrangements. These demonstrations should be in addition to the review or inspections of manuals, records, facilities and equipment. Some of the approvals required by Annex 6, Part I, such as approval for Category III operations, have significant safety implications and should be validated by demonstration before the State approves such operations.

2.2.2 While the specific methodology and extent of the required demonstrations and evaluations vary between States, the certification processes of States whose operators have good safety records are generally consistent. In these States, technically qualified inspectors evaluate a representative sample of the actual training, maintenance and operations prior to the issuance of an AOC or additional authorizations to the AOC.

2.3 Recording of certification actions

2.3.1 It is important that the certification, approval and acceptance actions of the State are adequately documented. The State should issue a written instrument, such as a letter or formal document, as an official record of the action. These written instruments should be retained as long as the operator continues to exercise the authorizations for which the approval or acceptance action was issued. These instruments are unambiguous evidence of the authorizations held by an operator and provide proof in the event that the State and the operator disagree on the operations that the operator is authorized to conduct.

2.3.2 Some States collect certification records such as inspections, demonstrations, approvals and acceptance instruments into a single file which is retained as long as the operator is active. Other States retain these records in files according to the certification action performed, and revise the file as the approvals or acceptance instruments are updated. Regardless of the method used, these certification records are persuasive evidence that a State is complying with its ICAO obligations regarding operator certification.

2.4 Coordination of operations and airworthiness evaluations

Some of the references to approval or acceptance in Annex 6, Part I, will require an operations evaluation and an airworthiness evaluation. Low minima approvals for the conduct of Category II and III ILS approaches, for example, require coordinated prior evaluation by operations and airworthiness specialists. Flight operations specialists should evaluate the operational procedures, training and qualifications. Airworthiness specialists should evaluate the aircraft, equipment reliability and

maintenance procedures. These evaluations may be accomplished separately, but should be coordinated to ensure that all aspects necessary for safety have been addressed before any approval is issued.

2.5 State of the Operator and State of Registry responsibilities

2.5.1 Annex 6, Part I, places the responsibility for initial certification, issuance of the AOC, and ongoing surveillance of an air operator on the State of the Operator. Annex 6, Part I, also requires the State of the Operator to consider or act in accordance with various approvals and acceptances by the State of Registry. Under these provisions, the State of the Operator should ensure that its actions are consistent with the approvals and acceptances of the State of Registry and that the air operator is in compliance with State of Registry requirements.

2.5.2 It is essential that the State of the Operator be satisfied with the arrangements by which its air operators use aircraft on the register of another State, particularly for maintenance and crew training. The State of the Operator should review such arrangements in coordination with the State of Registry. Where appropriate, an agreement transferring oversight responsibilities from the State of Registry to the State of the Operator pursuant to Article 83 *bis* to the Convention on International Civil Aviation should be arranged to preclude any misunderstandings regarding which State is responsible for specific oversight responsibilities.

Note.— Guidance concerning the responsibilities of the State of the Operator and the State of Registry in connection with lease, charter and interchange operations is contained in the Manual of Procedures for Operations Inspection, Certification and Continued Surveillance (Doc 8335). Guidance concerning the transfer of State of Registry responsibilities to the State of the Operator in accordance with Article 83 bis is contained in Guidance on the Implementation of Article 83 bis of the Convention on International Civil Aviation (Cir 295).

3. Approval actions

3.1 Approvals

The term “approval” implies a more formal action on the part of the State with respect to a certification matter than does the term “acceptance”. Some States require the Director of the Civil Aviation Authority (CAA) or a designated lower-level CAA official to issue a formal written instrument for every “approval” action taken. Other States allow a variety of documents to be issued as evidence of an approval. The approval document issued and the matter addressed by the approval will depend on the delegated authority of the official. In such States, authority to sign routine approvals, such as operator minimum equipment lists for specific aircraft, is delegated to technical inspectors. More complex or significant approvals are normally issued by higher-level officials.

3.2 Air operator certificate (AOC)

3.2.1 The AOC required by Annex 6, Part I, Chapter 4, 4.2.1, is a formal instrument. Chapter 4, 4.2.1.5, lists the information to be included in the AOC.

3.2.2 In addition to the items in Appendix 6, paragraph 3, operations specifications may include other specific authorizations, such as:

- a) special aerodrome operations (e.g. short take-off and landing operations or land and hold short operations);
- b) special approach procedures (e.g. steep gradient approach, instrument landing system precision runway monitor approach, localizer-type directional aid precision runway monitor approach, RNP approach);

- c) single-engine passenger transport at night or in instrument meteorological conditions; and
- d) operations in areas with special procedures (e.g. operations in areas using different altimetry units or altimeter setting procedures).

3.3 Provisions that require an approval

The following provisions require or encourage approval by specified States. The approval of the State of the Operator is required in all of the certification actions listed below that are not preceded by one or more asterisks. Certification actions listed below that are preceded by one or more asterisks require approval by the State of Registry (single asterisk or “*”), or by the State of Design (double asterisk or “**”). However, the State of the Operator should take the necessary steps to ensure that operators for which it is responsible comply with any applicable approvals issued by the State of Registry and/or State of Design, in addition to its own requirements.

- a) **Configuration deviation list (CDL) (Definitions);
- b) **Master minimum equipment list (MMEL) (Definitions);
- c) The method for establishing minimum flight altitudes (4.2.7.3);
- d) The method of determining aerodrome operating minima (4.2.8.1);
- e) Additional requirements for single pilot operations under the instrument flight rules (IFR) at night (4.9.1);
- f) Flight time, flight duty periods and rest periods (4.2.11.2);
- g) Specific extended range operations (4.7.1);
- h) Additional requirements for operations of single-engine turbine-powered aeroplanes at night and/or in instrument meteorological conditions (IMC) (5.4.1);
- i) Aircraft-specific minimum equipment list (MEL) (6.1.3);
- j) Performance-based navigation operations (7.2.2 b));
- k) MNPS operations (7.2.3 b));
- l) RVSM operations (7.2.4 b));
- m) Procedures for electronic navigation data management (7.4.1);
- n) *Aircraft-specific maintenance programme (8.3.1);
- o) *Approved maintenance organization (8.7.1.1);
- p) *Maintenance quality assurance methodology (8.7.4.1);
- q) Flight crew training programmes (9.3.1);
- r) Training in the transport of dangerous goods (9.3.1, Note 5);
- s) Aerodrome additional safety margin (9.4.3.3 a));

- t) Pilot-in-command area, route and aerodrome qualifications (9.4.3.5);
- u) Use of flight simulation training devices (9.3.1, Note 2 and 9.4.4, Note 1);
- v) Method of control and supervision of flight operations (4.2.1.3 and 10.1);
- w) **Mandatory maintenance tasks and intervals (11.3.2);
- x) Cabin attendant training programmes (12.4).

3.4 Provisions that require a technical evaluation

Other provisions in Annex 6, Part I, require the State to have made a technical evaluation. These provisions contain the phrases “acceptable to the State”, “satisfactory to the State”, “determined by the State”, “deemed acceptable by the State”, and “prescribed by the State”. While not necessarily requiring an approval by the State, these Standards do require the State to at least accept the matter at issue after it conducts a specific review or evaluation. These provisions are:

- a) details of the aircraft-specific checklists (Definition: aircraft operating manual and 6.1.4);
- b) details of the aircraft-specific systems (Definition: aircraft operating manual and 6.1.4);
- c) mandatory material for the operations manual (4.2.3.2/ Appendix 2);
- d) engine trend monitoring systems (5.4.2);
- e) equipment for aeroplanes operated by a single pilot under the instrument flight rules or at night (6.22);
- f) requirements for approval to operate in RVSM airspace (7.2.5);
- g) monitoring of height-keeping performance of aeroplanes approved to operate in RVSM airspace (7.2.6);
- h) procedures for distribution and insertion of electronic navigation data in aircraft (7.4.2);
- i) *operator’s aircraft-specific maintenance responsibilities (8.1.1);
- j) *method of maintenance and release (8.1.2);
- k) *maintenance control manual (8.2.1);
- l) *mandatory material for the maintenance control manual (8.2.4);
- m) *reporting of maintenance experience information (8.5.1);
- n) *implementing necessary maintenance corrective actions (8.5.2);
- o) *modification and repair requirements (8.6);
- p) *minimum competence level of maintenance personnel (8.7.6.3);
- q) requirement for flight navigator (9.1.4);
- r) training facilities (9.3.1);

- s) qualifications of instructors (9.3.1);
- t) need for recurrent training (9.3.1);
- u) use of correspondence courses and written examinations (9.3.1, Note 4);
- v) use of flight simulation training devices (9.3.2);
- w) flight crew qualification records (9.4.3.4);
- x) designated representative of the State of the Operator (9.4.4);
- y) pilot experience, recency and training requirements for single pilot operations under the instrument flight rules (IFR) or at night (9.4.5.1 and 9.4.5.2);
- z) *flight manual changes (11.1);
- aa) minimum number of flight attendants assigned to a specific aircraft (12.1);
- bb) altimetry system performance requirements for operations in RVSM airspace (Appendix 4, 1 and 2);

Single-engine operations

- cc) turbine engine reliability for approved operations by single-engine turbine-powered aeroplanes at night and/or in instrument meteorological conditions (IMC) (Appendix 3, 1.1);
- dd) systems and equipment (Appendix 3, 2);
- ee) minimum equipment list (Appendix 3, 3);
- ff) flight manual information (Appendix 3, 4);
- gg) event reporting (Appendix 3, 5);
- hh) operator planning (Appendix 3, 6);
- ii) flight crew experience, training and checking (Appendix 3, 7);
- jj) route limitations over water (Appendix 3, 8); and
- kk) operator certification or validation (Appendix 3, 9).

4. Acceptance actions

4.1 Acceptance

4.1.1 The actual extent of the State's technical evaluation of an operator's readiness to conduct certain flight operations should be much broader than just those Standards which require or imply approval. During certification, the State should ensure that an operator will be in compliance with all requirements of Annex 6, Part I, prior to conducting international commercial air transport operations.

4.1.2 The concept of “acceptance” is used by some States as a formal method of ensuring that all critical aspects of operator certification are reviewed by the State prior to the formal issuance of the AOC. Using this concept, these States exercise their prerogative to have technical inspectors review all operators’ policies and procedures impacting operational safety. The actual execution of an instrument to reflect this acceptance (assuming such a document is issued) may be delegated to the technical inspector assigned to the certification.

4.2 Conformance report

Some States use a conformance report to document the acceptances it makes with regard to a particular operator. This is a document submitted by the operator detailing how, with specific references to operations or maintenance manuals, it will comply with all applicable State regulations. This type of document is referenced in Doc 8335 and the *Airworthiness Manual* (Doc 9760), Volume I, 6.2.1 c) 4). Such a conformance report should be actively used during the certification process and revised as necessary to reflect modifications required by the State in the operator’s policies and procedures. Then a final conformance report is included in the State’s certification records, along with other records of certification. The conformance report is an excellent method of demonstrating that the operator was properly certificated with respect to all applicable regulatory requirements.

4.3 Operations and maintenance manuals

4.3.1 Operations and maintenance manuals, and any subsequent amendments should be submitted to the State (4.2.3.2, 8.1.1, 8.2.4, 8.3.2, and 8.7.2.3). The State also establishes minimum contents for these manuals (11.2, 11.3, 11.4 and Appendix 2). The pertinent portions of an operator’s manual for evaluation should be identified in the State’s technical guidance, e.g. operations policy manual, operating manual, cabin crew manual, route guide, and training manual. Some States issue a formal instrument accepting each manual and any subsequent amendments.

4.3.2 The State’s technical evaluation should, in addition to ensuring that all required contents are addressed, consider if the specific policies and procedures would result in the desired outcome. For example, the specifications for the operational flight plan (Appendix 2, 2.1.16) should provide the step-by-step completion guidance necessary for compliance with 4.3 concerning the content and retention of these plans.

4.3.3 Proven industry practices, such as an example of an actual completed operational flight plan for reference by the flight crew and dispatchers (although not a Standard), may also be required by a State’s technical evaluator during certification. This aspect of the technical evaluation should be conducted by inspectors experienced in operator certification. A major consideration with respect to evaluating for proven industry practices that are aircraft-specific, equipment-specific or have limited applications is the employment of evaluators who are currently qualified in the practice to be evaluated.

5. Other approval or acceptance considerations

Some States provide for approval or acceptance of certain critical documents, records or procedures specified in Annex 6, Part I, although the relevant Annex 6 Standards do not require approval or acceptance by the State of the Operator. The following are some examples:

- a) safety programme (3.3.1);
- b) flight data analysis programme (3.3.7);
- c) method for obtaining aeronautical data (4.1.1);
- d) adequacy of the fuel and oil records (4.2.10);

- e) adequacy of flight time, flight duty and rest period records (4.2.11.3, 9.6, and 12.5);
- f) adequacy of the aircraft maintenance log book (4.3.1 a), b), and c));
- g) adequacy of the load manifest (4.3.1 d), e) and f));
- h) adequacy of the operational plan (4.3.1 g));
- i) method for obtaining weather data (4.3.5.1 and 4.3.5.2);
- j) method of compliance with carry-on baggage stowage (4.8);
- k) aeroplane performance operating limitations (5.2.4);
- l) method of obtaining and applying aerodrome obstacle data (5.3);
- m) adequacy of passenger information cards (6.2.2 d));
- n) procedures for long-range navigation (7.2.1 b));
- o) contents of the journey log book (11.4.1); and
- p) content of the security training programme (13.4).

6. Validation of the standard of operations

Standard 4.2.1.4 requires that the validity of an AOC shall depend upon the operator maintaining the original certification standards (4.2.1.3) under the supervision of the State of the Operator. This supervision requires that a system of continued surveillance be established to ensure the required standards of operations are maintained (4.2.1.9). A good starting point in the development of such a system is to require annual or semi-annual inspections, observations and tests to validate the required certification approval and acceptance actions.

7. Amendment of air operator certificates

The certification of an operator is an ongoing process. Few operators will be satisfied over time with the initial authorizations issued with their AOC. Evolving market opportunities will cause an operator to change aircraft models and seek approval for new operational areas requiring other additional capabilities. Additional technical evaluations should be required by the State before issuing the formal written instruments approving any changes to the original AOC and other authorizations. Where possible, each request should be “bridged”, using the original authorization as the foundation to determine the extent of the State’s impending evaluation before issuing the formal instrument.

ATTACHMENT F. MINIMUM EQUIPMENT LIST (MEL)

Supplementary to Chapter 6, 6.1.2

1. If deviations from the requirements of States in the certification of aircraft were not permitted an aircraft could not be flown unless all systems and equipment were operable. Experience has proved that some unserviceability can be accepted in the short term when the remaining operative systems and equipment provide for continued safe operations.
2. The State should indicate through approval of a minimum equipment list those systems and items of equipment that may be inoperative for certain flight conditions with the intent that no flight can be conducted with inoperative systems and equipment other than those specified.
3. A minimum equipment list, approved by the State of the Operator, is therefore necessary for each aircraft, based on the master minimum equipment list established for the aircraft type by the organization responsible for the type design in conjunction with the State of Design.
4. The State of the Operator should require the operator to prepare a minimum equipment list designed to allow the operation of an aircraft with certain systems or equipment inoperative provided an acceptable level of safety is maintained.
5. The minimum equipment list is not intended to provide for operation of the aircraft for an indefinite period with inoperative systems or equipment. The basic purpose of the minimum equipment list is to permit the safe operation of an aircraft with inoperative systems or equipment within the framework of a controlled and sound programme of repairs and parts replacement.
6. Operators are to ensure that no flight is commenced with multiple minimum equipment list items inoperative without determining that any interrelationship between inoperative systems or components will not result in an unacceptable degradation in the level of safety and/or undue increase in the flight crew workload.
7. The exposure to additional failures during continued operation with inoperative systems or equipment must also be considered in determining that an acceptable level of safety is being maintained. The minimum equipment list may not deviate from requirements of the flight manual limitations section, emergency procedures or other airworthiness requirements of the State of Registry or of the State of the Operator unless the appropriate airworthiness authority or the flight manual provides otherwise.
8. Systems or equipment accepted as inoperative for a flight should be placarded where appropriate, and all such items should be noted in the aircraft technical log to inform the flight crew and maintenance personnel of the inoperative system or equipment.
9. For a particular system or item of equipment to be accepted as inoperative, it may be necessary to establish a maintenance procedure, for completion prior to flight, to de-activate or isolate the system or equipment. It may similarly be necessary to prepare an appropriate flight crew operating procedure.
10. The responsibilities of the pilot-in-command in accepting an aeroplane for operation with deficiencies in accordance with a minimum equipment list are specified in Chapter 4, 4.3.1.

ATTACHMENT G. FLIGHT SAFETY DOCUMENTS SYSTEM

Supplementary to Chapter 3, 3.3

1. Introduction

1.1 The following material provides guidance on the organization and development of an operator's flight safety documents system. It should be understood that the development of a flight safety documents system is a complete process, and changes to each document comprising the system may affect the entire system. Guidelines applicable to the development of operational documents have been produced by government and industry sources and are available to operators. Nevertheless, it may be difficult for operators to make the best use of these guidelines, since they are distributed across a number of publications.

1.2 Furthermore, guidelines applicable to operational documents development tend to focus on a single aspect of documents design, for example, formatting and typography. Guidelines rarely cover the entire process of operational documents development. It is important for operational documents to be consistent with each other, and consistent with regulations, manufacturer requirements and Human Factors principles. It is also necessary to ensure consistency across departments as well as consistency in application. Hence the emphasis on an integrated approach, based on the notion of the operational documents as a complete system.

1.3 The guidelines in this Attachment address the major aspects of an operator's flight safety documents system development process, with the aim of ensuring compliance with Chapter 3, 3.3. The guidelines are based not only upon scientific research, but also upon current best industry practices, with an emphasis on a high degree of operational relevance.

2. Organization

2.1 A flight safety documents system should be organized according to criteria which ensure easy access to information required for flight and ground operations contained in the various operational documents comprising the system and which facilitate management of the distribution and revision of operational documents.

2.2 Information contained in a flight safety documents system should be grouped according to the importance and use of the information, as follows:

- a) time-critical information, e.g., information that can jeopardize the safety of the operation if not immediately available;
- b) time-sensitive information, e.g., information that can affect the level of safety or delay the operation if not available in a short time period;
- c) frequently used information;
- d) reference information, e.g., information that is required for the operation but does not fall under b) or c) above; and
- e) information that can be grouped based on the phase of operation in which it is used.

2.3 Time-critical information should be placed early and prominently in the flight safety documents system.

2.4 Time-critical information, time-sensitive information, and frequently used information should be placed in cards and quick-reference guides.

3. Validation

The flight safety documents system should be validated before deployment, under realistic conditions. Validation should involve the critical aspects of the information use, in order to verify its effectiveness. Interactions among all groups that can occur during operations should also be included in the validation process.

4. Design

4.1 A flight safety documents system should maintain consistency in terminology and in the use of standard terms for common items and actions.

4.2 Operational documents should include a glossary of terms, acronyms and their standard definition, updated on a regular basis to ensure access to the most recent terminology. All significant terms, acronyms and abbreviations included in the flight documents system should be defined.

4.3 A flight safety documents system should ensure standardization across document types, including writing style, terminology, use of graphics and symbols, and formatting across documents. This includes a consistent location of specific types of information, consistent use of units of measurement and consistent use of codes.

4.4 A flight safety documents system should include a master index to locate, in a timely manner, information included in more than one operational document.

Note.— The master index must be placed in the front of each document and consist of no more than three levels of indexing. Pages containing abnormal and emergency information must be tabbed for direct access.

4.5 A flight safety documents system should comply with the requirements of the operator's quality system, if applicable.

5. Deployment

Operators should monitor deployment of the flight safety documents system, to ensure appropriate and realistic use of the documents, based on the characteristics of the operational environment and in a way which is both operationally relevant and beneficial to operational personnel. This monitoring should include a formal feedback system for obtaining input from operational personnel.

6. Amendment

6.1 Operators should develop an information gathering, review, distribution and revision control system to process information and data obtained from all sources relevant to the type of operation conducted, including, but not limited to, the State of the Operator, State of design, State of Registry, manufacturers and equipment vendors.

Note.— Manufacturers provide information for the operation of specific aircraft that emphasizes the aircraft systems and procedures under conditions that may not fully match the requirements of operators. Operators should ensure that such information meets their specific needs and those of the local authority.

6.2 Operators should develop an information gathering, review and distribution system to process information resulting from changes that originate within the operator, including:

- a) changes resulting from the installation of new equipment;
- b) changes in response to operating experience;
- c) changes in an operator's policies and procedures;
- d) changes in an operator certificate; and
- e) changes for purposes of maintaining cross fleet standardization.

Note.— Operators should ensure that crew coordination philosophy, policies and procedures are specific to their operation.

6.3 A flight safety documents system should be reviewed:

- a) on a regular basis (at least once a year);
- b) after major events (mergers, acquisitions, rapid growth, downsizing, etc.);
- c) after technology changes (introduction of new equipment); and
- d) after changes in safety regulations.

6.4 Operators should develop methods of communicating new information. The specific methods should be responsive to the degree of communication urgency.

Note.— As frequent changes diminish the importance of new or modified procedures, it is desirable to minimize changes to the flight safety documents system.

6.5 New information should be reviewed and validated considering its effects on the entire flight safety documents system.

6.6 The method of communicating new information should be complemented by a tracking system to ensure currency by operational personnel. The tracking system should include a procedure to verify that operational personnel have the most recent updates.

ATTACHMENT H. ADDITIONAL GUIDANCE FOR APPROVED OPERATIONS BY SINGLE-ENGINE TURBINE-POWERED AEROPLANES AT NIGHT AND/OR IN INSTRUMENT METEOROLOGICAL CONDITIONS (IMC)

Supplementary to Chapter 5, 5.4 and Appendix 3

1. Purpose and scope

The purpose of this attachment is to give additional guidance on the airworthiness and operational requirements described in Chapter 5, 5.4 and Appendix 3, which have been designed to meet the overall level of safety intended for approved operations by single-engine turbine-powered aeroplanes at night and/or in IMC.

2. Turbine engine reliability

2.1 The power loss rate required in Chapter 5, 5.4.1 and Appendix 3 should be established as likely to be met based on data from commercial operations supplemented by available data from private operations in similar theatres of operation. A minimum amount of service experience is needed on which to base the judgment, and this should include at least 20 000 hours on the actual aeroplane/engine combination unless additional testing has been carried out or experience on sufficiently similar variants of the engine is available.

2.2 In assessing turbine engine reliability, evidence should be derived from a world fleet database covering as large a sample as possible of operations considered to be representative, compiled by the manufacturers and reviewed with the States of Design and of the Operator. Since flight hour reporting is not mandatory for many types of operators, appropriate statistical estimates may be used to develop the engine reliability data. Data for individual operators approved for these operations including trend monitoring and event reports should also be monitored and reviewed by the State of the Operator to ensure that there is no indication that the operator's experience is unsatisfactory.

2.2.1 Engine trend monitoring should include the following:

- a) an oil consumption monitoring programme based on manufacturers' recommendations; and
- b) an engine condition monitoring programme describing the parameters to be monitored, the method of data collection and the corrective action process; this should be based on the manufacturer's recommendations. The monitoring is intended to detect turbine engine deterioration at an early stage to allow for corrective action before safe operation is affected.

2.2.2 A reliability programme should be established covering the engine and associated systems. The engine programme should include engine hours flown in the period and the in-flight shutdown rate for all causes and the unscheduled engine removal rate, both on a 12-month moving average basis. The event reporting process should cover all items relevant to the ability to operate safely at night and/or in IMC. The data should be available for use by the operator, the Type Certificate Holder and the State so as to establish that the intended reliability levels are being achieved. Any sustained adverse trend should result in an immediate evaluation by the operator in consultation with the State and manufacturer with a view to determining actions to restore the intended safety level. The operator should develop a parts control programme with support from the manufacturer that ensures that the proper parts and configuration are maintained for single-engine turbine-powered aeroplanes approved to

conduct these operations. The programme includes verification that parts placed on an approved single-engine turbine-powered aeroplane during parts borrowing or pooling arrangements, as well as those parts used after repair or overhaul, maintain the necessary configuration of that aeroplane for operations approved in accordance with Chapter 5, 5.4.

2.3 Power loss rate should be determined as a moving average over a specified period (e.g. a 12-month moving average if the sample is large). Power loss rate, rather than in-flight shut-down rate, has been used as it is considered to be more appropriate for a single-engine aeroplane. If a failure occurs on a multi-engine aeroplane that causes a major, but not total, loss of power on one engine, it is likely that the engine will be shut down as positive engine-out performance is still available, whereas on a single-engine aeroplane it may well be decided to make use of the residual power to stretch the glide distance.

2.4 The actual period selected should reflect the global utilization and the relevance of the experience included (e.g. early data may not be relevant due to subsequent mandatory modifications which affected the power loss rate). After the introduction of a new engine variant and whilst global utilization is relatively low, the total available experience may have to be used to try to achieve a statistically meaningful average.

3. Operations manual

The operations manual should include all necessary information relevant to operations by single-engine turbine-powered aeroplanes at night and/or in IMC. This should include all of the additional equipment, procedures and training required for such operations, route and/or area of operation and aerodrome information (including planning and operating minima).

4. Operator certification or validation

The certification or validation process specified by the State of the Operator should ensure the adequacy of the operator's procedures for normal, abnormal and emergency operations, including actions following engine, systems or equipment failures. In addition to the normal requirements for operator certification or validation, the following items should be addressed in relation to operations by single-engine turbine-powered aeroplanes:

- a) proof of the achieved engine reliability of the aeroplane engine combination (see Appendix 3, paragraph 1);
- b) specific and appropriate training and checking procedures including those to cover engine failure/malfunction on the ground, after take-off and en-route and descend to a forced landing from the normal cruising altitude;
- c) a maintenance programme which is extended to address the equipment and systems referred to in Appendix 3, paragraph 2;
- d) an MEL modified to address the equipment and systems necessary for operations at night and/or in IMC;
- e) planning and operating minima appropriate to the operations at night and/or in IMC;
- f) departure and arrival procedures and any route limitations;
- g) pilot qualifications and experience; and
- h) the operations manual, including limitations, emergency procedures, approved routes or areas of operation, the MEL and normal procedures related to the equipment referred to in Appendix 3, paragraph 2.

5. Operational and maintenance programme requirements

5.1 Approval to undertake operations by single-engine turbine-powered aeroplanes at night and/or in IMC specified in an air operator certificate or equivalent document should include the particular airframe/engine combinations, including the current type design standard for such operations, the specific aeroplanes approved, and the areas or routes of such operations.

5.2 The operator's maintenance control manual should include a statement of certification of the additional equipment required, and of the maintenance and reliability programme for such equipment, including the engine.

6. Route limitations over water

6.1 Operators of single-engine turbine-powered aeroplanes carrying out operations at night and/or in IMC should make an assessment of route limitations over water. The distance that the aeroplane may be operated from a land mass suitable for a safe forced landing should be determined. This equates to the glide distance from the cruise altitude to the safe forced landing area following engine failure, assuming still air conditions. States may add to this an additional distance taking into account the likely prevailing conditions and type of operation. This should take into account the likely sea conditions, the survival equipment carried, the achieved engine reliability and the search and rescue services available.

6.2 Any additional distance allowed beyond the glide distance should not exceed a distance equivalent to 15 minutes at the aeroplane's normal cruise speed.

ATTACHMENT I. FRAMEWORK FOR THE STATE SAFETY PROGRAMME (SSP)

This attachment introduces a framework for the implementation and maintenance of a State safety programme (SSP) by a State. An SSP is a management system for the management of safety by the State. The framework contemplates four components and eleven elements, outlined hereunder. The implementation of an SSP is commensurate with the size and complexity of the State's aviation system and may require coordination among multiple authorities responsible for individual elements of civil aviation functions in the State. The SSP framework introduced in this attachment, and the safety management system (SMS) framework specified in Appendix 7, must be viewed as complementary, yet distinct, frameworks. This attachment also includes a brief description of each element of the framework.

1. State safety policy and objectives
 - 1.1 State safety legislative framework
 - 1.2 State safety responsibilities and accountabilities
 - 1.3 Accident and incident investigation
 - 1.4 Enforcement policy
2. State safety risk management
 - 2.1 Safety requirements for the service provider's SMS
 - 2.2 Agreement on the service provider's safety performance
3. State safety assurance
 - 3.1 Safety oversight
 - 3.2 Safety data collection, analysis and exchange
 - 3.3 Safety-data-driven targeting of oversight of areas of greater concern or need
4. State safety promotion
 - 4.1 Internal training, communication and dissemination of safety information
 - 4.2 External training, communication and dissemination of safety information

Note.— Within the context of this attachment the term “service provider” refers to any organization providing aviation services. The term includes approved training organizations that are exposed to safety risks during the provision of their services, aircraft operators, approved maintenance organizations, organizations responsible for type design and/or manufacture of aircraft, air traffic services providers and certified aerodromes, as applicable.

1. State safety policy and objectives

1.1 State safety legislative framework

The State has promulgated a national safety legislative framework and specific regulations, in compliance with international and national standards, that define how the State will conduct the management of safety in the State. This includes the

participation of State aviation organizations in specific activities related to the management of safety in the State, and the establishment of the roles, responsibilities and relationships of such organizations. The safety legislative framework and specific regulations are periodically reviewed to ensure they remain relevant and appropriate to the State.

1.2 State safety responsibilities and accountabilities

The State has identified, defined and documented the requirements, responsibilities and accountabilities regarding the establishment and maintenance of the SSP. This includes the directives to plan, organize, develop, maintain, control and continuously improve the SSP in a manner that meets the State's safety objectives. It also includes a clear statement about the provision of the necessary resources for the implementation of the SSP.

1.3 Accident and incident investigation

The State has established an independent accident and incident investigation process, the sole objective of which is the prevention of accidents and incidents, and not the apportioning of blame or liability. Such investigations are in support of the management of safety in the State. In the operation of the SSP, the State maintains the independence of the accident and incident investigation organization from other State aviation organizations.

1.4 Enforcement policy

The State has promulgated an enforcement policy that establishes the conditions and circumstances under which service providers are allowed to deal with, and resolve, events involving certain safety deviations, internally, within the context of the service provider's safety management system (SMS), and to the satisfaction of the appropriate State authority. The enforcement policy also establishes the conditions and circumstances under which to deal with safety deviations through established enforcement procedures.

2. State safety risk management

2.1 Safety requirements for the service provider's SMS

The State has established the controls which govern how service providers will identify hazards and manage safety risks. These include the requirements, specific operating regulations and implementation policies for the service provider's SMS. The requirements, specific operating regulations and implementation policies are periodically reviewed to ensure they remain relevant and appropriate to the service providers.

2.2 Agreement on the service provider's safety performance

The State has agreed with individual service providers on the safety performance of their SMS. The agreed safety performance of an individual service provider's SMS is periodically reviewed to ensure it remains relevant and appropriate to the service providers.

3. State safety assurance

3.1 Safety oversight

The State has established mechanisms to ensure effective monitoring of the eight critical elements of the safety oversight function. The State has also established mechanisms to ensure that the identification of hazards and the management of safety risks by service providers follow established regulatory controls (requirements, specific operating regulations and implementation policies). These mechanisms include inspections, audits and surveys to ensure that regulatory safety risk controls are appropriately integrated into the service provider's SMS, that they are being practised as designed, and that the regulatory controls have the intended effect on safety risks.

3.2 Safety data collection, analysis and exchange

The State has established mechanisms to ensure the capture and storage of data on hazards and safety risks at both an individual and aggregate State level. The State has also established mechanisms to develop information from the stored data and to actively exchange safety information with service providers and/or other States, as appropriate.

3.3 Safety-data-driven targeting of oversight of areas of greater concern or need

The State has established procedures to prioritize inspections, audits and surveys towards those areas of greater safety concern or need, as identified by the analysis of data on hazards, their consequences in operations, and the assessed safety risks.

4. State safety promotion

4.1 Internal training, communication and dissemination of safety information

The State provides training and fosters awareness and two-way communication of safety-relevant information to support, within the State aviation organizations, the development of an organizational culture that fosters an effective and efficient SSP.

4.2 External training, communication and dissemination of safety information

The State provides education and promotes awareness of safety risks and two-way communication of safety-relevant information to support, among service providers, the development of an organizational culture that fosters an effective and efficient SMS.

ATTACHMENT J. HEAD-UP DISPLAYS (HUD) AND ENHANCED VISION SYSTEMS (EVS)

Supplementary to Chapter 6, 6.23

Introduction

The material in this Attachment provides guidance for HUD and EVS intended for installation and operational use in aircraft engaged in international air navigation. HUD and EVS may be installed and operated to enhance situational awareness or to obtain an operational credit such as lower minima for approach and landing operations. HUD and EVS may be installed separately or together as part of a hybrid system. Any use of these systems and any operational credit gained from their use requires approval from the State of the Operator.

Note.— Operational credit can only be granted within the limits of the design approval.

1. HUD

1.1 General

1.1.1 A HUD presents flight information into the pilot's forward external field of view without significantly restricting that external view.

1.1.2 A variety of flight information may be presented on a HUD depending on the intended flight operation, flight conditions, systems capabilities and operational approval. A HUD may include, but is not limited to, the following:

- a) airspeed;
- b) altitude;
- c) heading;
- d) vertical speed;
- e) angle of attack;
- f) flight path or velocity vector;
- g) attitude with bank and/or pitch references;
- h) course and glidepath with deviation indications;
- i) status indications (navigation sensor, autopilot, flight director, etc.); and
- j) alerts and warning displays (ACAS, wind shear, ground proximity warning, etc.).

1.2 HUD operational applications

1.2.1 Flight operations with HUD can improve situational awareness by combining flight information located on head-down displays with the external view to provide pilots with more immediate awareness of relevant flight parameters and situation information while they continuously view the external scene. This improved situational awareness can also reduce errors in flight operations and improve the pilot's ability to transition between visual and instrument references as meteorological conditions change. Flight operations applications may include the following:

- a) enhanced situational awareness during all flight operations, but especially during taxi, take-off, approach and landing;
- b) reduced flight technical error during take-off, approach and landing especially in all-weather operations; and
- c) improvements in performance due to precise prediction of touchdown area, tail strike awareness/warning and rapid recognition and recovery from unusual attitudes.

1.2.2 HUD may be used for the following purposes:

- a) to supplement conventional flight deck instrumentation in the performance of a particular task or operation. The primary cockpit instruments remain the primary means for manually controlling or manoeuvring the aircraft; and
- b) as a primary flight display;
 - i) information presented by the HUD may be used by the pilot in lieu of scanning head-down displays. Operational approval of a HUD for such use allows the pilot to control the aircraft by reference to the HUD for approved ground or flight operations; and
 - ii) information presented by the HUD may be used as a means to achieve additional navigation or control performance. The required information is displayed on the HUD. Operational credit, in the form of lower minima, for HUD used for this purpose may be approved for a particular aircraft or automatic flight control system. Additional credit may also be allowed to conduct operations with HUD in situations where automated systems are otherwise used.

1.3 HUD training

1.3.1 Training requirements should be established, monitored and approved by the State of the Operator. These training requirements should include requirements for recent experience if the State determines those requirements are significantly different than current requirements for the use of conventional head-down instrumentation.

1.3.2 HUD training should address all flight operations for which the HUD is designed and operationally approved. Some training elements may require adjustments based on whether the aeroplane has a single or dual HUD installation. Training should include contingency procedures required in the event of head-up display degradation or failure. HUD training should include the following elements as applicable to the intended use:

- a) an understanding of the HUD, its flight path and energy management concepts, and symbology. This should include operations during critical flight events (ACAS TA/RA, upset and wind shear recovery, engine or system failure, etc.);
- b) HUD limitations and normal procedures, including maintenance and operational checks performed to ensure normal system function prior to use. These checks include pilot seat adjustment to attain and maintain appropriate viewing angles and verification of HUD operating modes;
- c) HUD use during low visibility operations, including taxi, take-off, instrument approach and landing in both day and night conditions. This training should include the transition from head-down to head-up and head-up to head-down operations;

- d) failure modes of the HUD and the impact of the failure modes or limitations upon crew performance;
- e) crew coordination, monitoring and verbal call out procedures for single HUD installations with head-down monitoring for pilot-not-equipped with HUD and head-up monitoring for pilot-equipped with HUD;
- f) crew coordination, monitoring and verbal call-out procedures for dual HUD installations with use of HUD by the pilot flying the aircraft and either head-up or head-down monitoring by the other pilot;
- g) consideration of the potential for loss of situational awareness due to "tunnel vision" (also known as cognitive tunnelling or attention tunnelling);
- h) any effects that weather, such as low ceilings and visibilities, may have on the performance of a HUD; and
- i) HUD airworthiness requirements.

2. EVS

2.1 General

2.1.1 EVS present a real-time electronic image of the external scene through the use of image sensors. This information should be displayed on a head-up or head-down display. When enhanced vision imagery is displayed on a HUD, it should be presented to the pilots' forward external field of view without significantly restricting that external view.

2.1.2 A variety of image sensors may be used individually or in combination to present a real-time electronic image of the external scene. Image sensors may include sensors using low-level light intensification, thermal emissions, radar or other electronic emissions.

2.2 Operational applications

2.2.1 Flight operations with enhanced vision image sensors allow the pilot to view an image of the external scene obscured by darkness or other visibility restrictions. When the external scene is partially obscured, enhanced vision imaging may allow the pilot to acquire an image of the external scene earlier than with natural or unaided vision. The improved acquisition of an image of the external scene may improve situational awareness.

2.2.1.1 This enhanced imagery may also allow pilots to detect terrain or obstructions on the runway or taxiways. An enhanced image can also provide visual cues to enable earlier runway alignment and a more stabilized approach.

2.2.1.2 The enhanced vision images may also be used to obtain approval to use reduced visibility minima when the images are presented into the pilot's external field of view on a HUD without significantly restricting that view. The approval also requires specific aircraft performance parameters and navigation guidance to be presented on the HUD. The combined display of aircraft performance, guidance and imagery may allow the pilot to maintain a more stabilized approach and smoothly transition from enhanced visual references to standard visual references. This increased capability has enabled some States to approve approach and landing operations for operators using approved HUD with enhanced vision imagery when reported visibilities are less than normal published requirements.

2.3 EVS approval

2.3.1 Approval requirements differ based on whether the intended function of the system is to increase situational awareness or to obtain operational credit.

2.3.1.1 When enhanced vision imagery is used to improve situational awareness, operational approval requirements may be limited. An example of this type of operation may include an EVS on a head-down display that is only used for situational awareness of the surrounding area of the aircraft during ground operations where the display is not in the pilot's primary field of view. For enhanced situational awareness, the installation and operational procedures need to ensure that EVS operations do not interfere with normal procedures or the operation or use of other aircraft systems. In some cases, modifications to these normal procedures, other systems or equipment may be necessary to ensure compatibility.

2.3.1.2 When enhanced vision imagery is used for operational credit, operational approvals may require that the imagery be combined with flight guidance and presented on a HUD. Operational approvals may also require that this information be presented on a head-down display. A pilot could use this system to continue an instrument approach below published minimum altitudes using the enhanced visual imagery combined with flight guidance on the HUD. When EVS is used for operational credit, operational approval standards should ensure the credit for the individual image sensor or combination of sensors is appropriate. Operational credit may be applied for any flight operation, but credit for instrument approach and landing operations is most common.

2.4 EVS training

2.4.1 Training requirements should be established, monitored and approved by the State of the Operator. These training requirements should include recency of experience requirements if the State of the Operator determines those requirements are significantly different than current requirements for the use of HUD without enhanced vision imagery or conventional head-down instrumentation.

2.4.2 EVS training should address all flight operations for which the enhanced vision display is approved. This training should include contingency procedures required in the event of system degradation or failure. Training for EVS used for situational awareness should not interfere with other required operations. Training for EVS used for operational credit should also require training for the applicable HUD used to present the enhanced visual imagery. EVS training should include the following elements as applicable:

- a) an understanding of the system characteristics and operational constraints. Normal procedures, controls, modes, and system adjustments;
- b) EVS limitations;
- c) EVS airworthiness requirements;
- d) enhanced vision display during low visibility operations, including taxi, take-off, instrument approach and landing. System use for instrument approach procedures in both day and night conditions;
- e) failure modes of the EVS and the impact of the failure modes or limitations upon crew performance, in particular, for two-pilot operations;
- f) crew coordination and monitoring procedures and pilot call-out responsibilities;
- g) transition from enhanced imagery to visual conditions during the runway visual acquisition;
- h) rejected landing: loss of visual cues of the landing area, touchdown zone, or rollout area; and
- i) any effects that weather, such as low ceilings and visibilities, may have on the performance of an EVS.

Note.— LED runway lighting may not be visible to crews using HUD/EVS due to the fact that LEDs are non-incandescent lights. The effect of LED runway lighting on HUD/EVS is being evaluated, and the results will be included in a subsequent revision to Attachment J.

ATTACHMENT K. RESCUE AND FIRE FIGHTING SERVICES (RFFS) LEVELS

Supplementary to Chapter 4, 4.1.4

1. Purpose and scope

1.1 Introduction

The purpose of this Attachment is to provide guidance for assessing the level of RFFS deemed acceptable by aeroplane operators using aerodromes for different purposes.

1.2 Basic concepts

1.2.1 While all aeroplane operators should aim to have the level of RFFS protection required by Annex 14, Volume I, Chapter 9, 9.2, some of the aerodromes currently used do not meet these requirements. Furthermore, Annex 14, Volume I provisions relate to the level of aerodrome RFFS to be provided for aeroplanes normally using an aerodrome.

1.2.2 If an aerodrome is exposed to a temporary reduction of its RFFS capability, Annex 14, Volume I, 2.11.3, requires that: “Changes in the level of protection normally available at an aerodrome for rescue and fire fighting shall be notified to the appropriate air traffic services units and aeronautical information services units to enable those units to provide the necessary information to arriving and departing aircraft. When such a change has been corrected, the above units shall be advised accordingly.”

1.2.3 The following guidance is intended to assist operators in making the assessment required by Chapter 4, 4.1.4. It is not intended that this guidance limit or regulate the operation of an aerodrome.

2. Glossary of terms

Aerodrome RFFS category. The RFFS category for a given aerodrome, as published in the appropriate Aeronautical Information Publication (AIP).

Aeroplane RFFS category. The category derived from Annex 14, Volume I, Table 9-1 for a given aeroplane type.

RFFS category. Rescue and fire fighting services category as defined in Annex 14, Volume I, Chapter 9.

Temporary downgrade. RFFS category as notified, including by NOTAM, and resulting from the downgrade of the level of RFFS protection available at an aerodrome, for a period of time not exceeding 72 hours.

3. Minimum acceptable aerodrome RFFS category

3.1 Planning

3.1.1 In principle, the published RFFS category for each of the aerodromes used for a given flight should be equal to or better than the aeroplane RFFS category. However, if the aeroplane RFFS category is not available at one or more of the aerodromes required to be specified in the operational flight plan, an operator should ensure that the aerodrome has the minimum level of RFFS which is deemed acceptable for the intended use in accordance with the instructions contained in the operations manual. When establishing acceptable levels of minimum RFFS for these situations, the operator may use the criteria in Table K-1.

3.1.1.1 Intended operations to aerodromes with RFFS categories below the levels specified in Annex 14, Volume I, Chapter 9, 9.2, should be coordinated between the aeroplane operator and the aerodrome operator.

Table K-1. Minimum acceptable aerodrome category for rescue and fire fighting

Aerodromes (Required to be specified in the operational flight plan) ⁽¹⁾	Minimum acceptable aerodrome RFFS category (Based on published aerodrome RFFS category)
Departure and destination aerodrome	RFFS category for each aerodrome should be equal to or better than the aeroplane RFFS category. One category ⁽²⁾ below the aeroplane RFFS category may be accepted where provided as a remission in accordance with Annex 14, Volume I, 9.2, but not lower than Category 4 for aeroplanes with maximum certificated take-off mass of over 27 000 kg and not lower than Category 1 for other aeroplanes.
Departure and destination aerodrome in case of temporary downgrade and Take-off alternate, destination alternate and en-route alternate aerodromes	Two categories below the aeroplane RFFS category, but not lower than Category 4 for aeroplanes with maximum certificated take-off mass of over 27 000 kg and not lower than Category 1 for other aeroplanes.
EDTO en-route alternate aerodrome	RFFS Category 4 for aeroplanes with maximum certificated take-off mass of over 27 000 kg or not lower than Category 1 for all other aeroplanes, under the condition that at least 30 minutes' notice will be given to the aerodrome operator prior to the arrival of the aeroplane.

Notes.—

- (1) If an individual aerodrome serves more than one purpose, the highest required category corresponding to that purpose at the time of expected use applies.
- (2) Annex 14, Volume I, determines the aerodrome category for rescue and fire fighting according to 9.2.5 and 9.2.6 except that, where the number of movements of the aeroplanes in the highest category normally using the aerodrome is less than 700 in the busiest consecutive three months, the category provided may be one lower than the determined category.

3.1.2 For all-cargo operations, further reductions might be acceptable provided that the RFFS capability is adequate to arrest fire around the flight deck area long enough for the persons on board to safely evacuate the aeroplane.

3.2 In flight

3.2.1 In flight, the pilot-in-command may decide to land at an aerodrome regardless of the RFFS category if, in the pilot's judgement after due consideration of all prevailing circumstances, to do so would be safer than to divert.

— END —

