

Safety **First**

The Airbus Safety Magazine



6

JULY 2008



AIRBUS

Editorial

06 | July 2008



Yannick MALINGE

Vice President

Flight Safety



Content

Dear Customers and Aviation Safety colleagues,

Runway excursions remain one of the three main accident categories, accounting for about a quarter of all accidents in 2007.

The following two main contributing factors to these events have been well identified in the past by the aviation community :

- Unstabilized approaches
- Lack of go-around decision

As announced in the previous issue of this magazine, the “A320/ Runway overrun” article that you will find hereafter illustrates very well the need to repeat the lessons learnt from these occurrences. This is particularly true for the new entrants in the aviation community.

On a different subject, we are very pleased to publish the article titled “FCTL check after EFCS reset on ground”, as it has been co-written by an Airbus operator.

Let me take this opportunity to remind you that we encourage our customer to share safety information that could bring added value to other Airbus operators, by providing airline safety articles for this magazine.

I hope you will enjoy reading this sixth issue of Safety First, and look forward to meet you at the 15th Flight Safety Conference in Paris.

Yours sincerely

Yannick MALINGE

Vice President Flight Safety

| | |
|--|----|
| The Airbus Safety Magazine | 1 |
| News | 2 |
| Information | 3 |
| A320/ Runway overrun M. Baillion | 4 |
| FCTL check after EFCS reset on ground K. Tritschler & A. Urdiroz | 10 |
| A320/ Possible consequences of VMO/MMO exceedance M. Palomèque | 14 |
| A320/ Prevention of tailstrikes M. Palomèque | 18 |
| Low fuel situations awareness F. Marani | 22 |
| Rudder pedal Jam J. Rendu | 27 |
| Why do certain AMM tasks require equipment resets? D. Harris | 29 |
| Slide/Raft Improvement F. Sauvage | 31 |
| Cabin attendant falling through the avionics bay access panel in cockpit P-O. Guenzel | 33 |

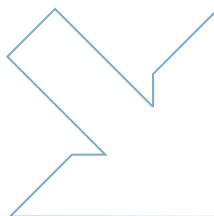



Safety First

The Airbus Safety Magazine

For the enhancement of safe flight through increased knowledge and communications.

Safety First is published by the Flight Safety Department of Airbus. It is a source of specialist safety information for the restricted use of flight and ground crew members who fly and maintain Airbus aircraft. It is also distributed to other selected organisations.

Material for publication is obtained from multiple sources and includes selected information from the Airbus Flight Safety Confidential Reporting System, incident and accident investigation reports, system tests and flight tests. Material is also obtained from sources within the airline industry, studies and reports from government agencies and other aviation sources.

All articles in Safety First are presented for information only and are not intended to replace ICAO guidelines, standards or recommended practices, operator-mandated

requirements or technical orders. The contents do not supersede any requirements mandated by the State of Registry of the Operator's aircraft or supersede or amend any Airbus type-specific AFM, AMM, FCOM, MEL documentation or any other approved documentation.

Articles may be reprinted without permission, except where copyright source is indicated, but with acknowledgement to Airbus. Where Airbus is not the author, the contents of the article do not necessarily reflect the views of Airbus, neither do they indicate Company policy.

Contributions, comment and feedback are welcome. For technical reasons the editors may be required to make editorial changes to manuscripts, however every effort will be made to preserve the intended meaning of the original. Enquiries related to this publication should be addressed to:

Airbus

Flight Safety Department (GSE)

1, rond point Maurice Bellonte

31707 Blagnac Cedex - France

Contact: Marie-Josée Escoubas

E-mail: marie-josee.escoubas@airbus.com

Fax: +33 (0)5 61 93 44 29

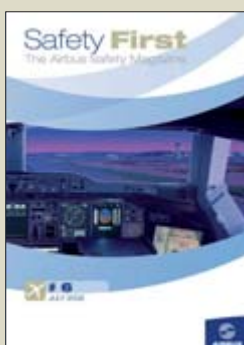

Safety First

06 July 2008

Safety First is published by Airbus S.A.S

1, rond point Maurice Bellonte
31707 Blagnac Cedex / France

Editor:

Yannick Malinge,

Vice President Flight Safety

Concept Design by

MUTI MEDIA SUPPORT 20080635

Computer Graphic by Quat'coul

Copyright: GSE 420 0279/08

Photos copyright Airbus

Photos by

ExM: Hervé Berenger, Philippe

Masclat, Hervé Goussé.

Photo copyright Germanwings

Computer rendering by ABAC

Printed in France by GWLNSD

© Airbus S.A.S. 2008 – All rights reserved. Confidential and proprietary documents.

By taking delivery of this Brochure (hereafter "Brochure"), you accept on behalf of your company to comply with the following guidelines:

- No other intellectual property rights are granted by the delivery of this Brochure than the right to read it, for the sole purpose of information.
- This Brochure and its content shall not be modified and its illustrations and photos shall not be reproduced without prior written consent of Airbus.
- This Brochure and the materials it contains shall not, in whole or in part, be sold, rented, or licensed to any third party subject to payment.

This Brochure contains sensitive information that is correct at the time of going to press. This information involves a number of factors that could change over time, effecting the true public representation. Airbus assumes no obligation to update any information contained in this document or with respect to the information described herein.

Airbus SAS shall assume no liability for any damage in connection with the use of this Brochure and of the materials it contains, even if Airbus SAS has been advised of the likelihood of such damages.



15th Flight Safety Conference

The planning for this year's conference is well underway. It will be held from the 20th to the 23rd of October in Paris. A provisional agenda has been defined and the invitations have been sent out in June. If you are an Airbus customer, and have not yet received an invitation, please contact Nuria Soler at the address below. Please note that this is a conference for Airbus and our customers only. We do not accept outside parties into the conference so as to ensure that we can have an open forum for everybody to share information.

As always we welcome presentations from you. The conference is a forum for everybody to share information, so if you have something you believe will benefit other operators and/or Airbus, then please contact us.

We look forward to meeting you all at the conference !

Contact: Mrs Nuria Soler
E-mail: nuria.soler@airbus.com
fax: +33 (0) 561934429





Information

Magazine distribution

If you wish to subscribe to Safety First, please fill out the subscription form that you will find at the end of this issue.

Please note that the paper copies will only be forwarded to professional addresses.

Your articles

This magazine is a tool to help share information, therefore we rely on your inputs. We are keen to receive articles from customers, that we can pass along to other operators through the magazine. If you wish to share your experience, please contact us.

Contact: Marie-Josée Escoubas
marie-josee.escoubas@airbus.com
Fax: +33 (0) 5 61 93 44 29

Safety Information on the Airbus websites

On the different Airbus websites we are building up more and more safety relevant information for you to use.

The present and previous issues of Safety First can be accessed to in the Flight Operations Community- Safety and Operational Materials chapter-, in the secure area of www.airbusworld.com

Or directly at the secure site at:
<https://w3.airbus.com/>

If you do not yet have access rights, then contact your IT administrator or refer to "Registration information" (top left of web page).

Other safety and operational expertise publications, like the Flight Operation Briefing Notes (FOBN), Getting to Grips with... brochures, e-briefings etc... are regularly released as well in the Flight Operations Community at the above sites.

The FOBN, referred to in some articles in this issue, may as well be found on the Safety Library room of the general public Airbus website at http://www.airbus.com/en/corporate/ethics/safety_lib/



Flight Safety

Hotline:

+33 (0)6 29 80 86 66

E-mail:

account.safety@airbus.com





A320/ Runway overrun

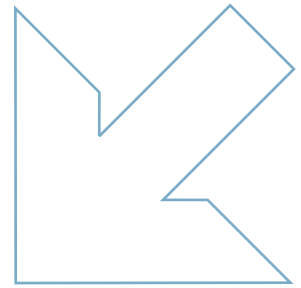

By: Marc BAILLION
Flight Safety Director

1 | Introduction

Runway excursions, together with Controlled Flight Into Terrain (CFIT), are one of the main categories of incidents and accidents. In the last two years, ten runway excursions were reported to Airbus. This article will describe one of these occurrences, where the aircraft was damaged beyond economical repair.

The root causes of this event are common to many other runway excursions, and it is therefore worthwhile to share the lessons learned from this accident and to repeat the following key safety messages:

- Fly stabilized approaches
- Be go-around minded

2 | Description of the event

An A320 performed a visual approach to a runway 12. The aircraft landed at 6h23' local time and overran the end of the 1966 meter long runway at a speed of approximately 85kt.

It stopped approximately 200 meters beyond the runway limit and the 156 occupants were able to evacuate the plane safely. There was no post impact fire, but the aircraft suffered a hull loss.

The following sequence of events has been retrieved from the DFDR and CVR. Data from the latter is incomplete as the Captain's voice was not audible.

Flight conditions at 4 700ft :

The aircraft was performing a visual approach. Gross weight was 64t (Max landing weight is 64.5t) Configuration clean (Slat 0° / Flaps 0°) with landing gears up and locked.

Autopilot 1 was engaged in DES (longitudinal mode) and NAV (lateral mode). Both Flight Directors (FD) were engaged. ATHR was engaged in thrust mode. Captain was the Pilot Flying (PF).

Selected altitude on FCU was 3 000ft.
Aircraft heading was 155°.

Wind speed was 23kt, and wind direction 300°. This resulted in a 20kt tailwind and a 13kt right crosswind.

Speed target was managed by the FMGC and was equal to 285kt.
CAS was 306kt
Vapp = 138kt

Approach

- Approaching 3 000ft, The crew contacted ATC :
- F/O : "... approaching 10 DME 3 000"
 - ATC : Roger and wind is calm.
Report finals runway 12".
 - F/O : "Check finals runway 12 ...".

As the aircraft approached 3 000ft, the A/P vertical mode changed to Altitude Acquire (ALT*) then to Altitude Hold (ALT). The ATHR changed to speed mode.

The A/P vertical mode was then changed to Flight Path Angle (FPA), with a selected -3° FPA target. The aircraft descended accordingly.

The selected FPA was then changed to 0° and the aircraft leveled off at 2 800ft RA. The crew selected configuration 1¹ and, 3 seconds later, landing gears down.

The crew armed the ground spoilers, and the selected FPA was successively changed to -3.6° , then to -5.5° and -7° after having selected configuration 2² at about 2 600ft RA (CAS was 198kt ; VFE = 200kt).

The F/O announced "Still high" and immediately after "Too close".

At 2 300ft RA, the Captain disconnected the A/P and disengaged both FD. ATC announced "Wind is calm³, cleared to land runway 12".

At 1 600ft RA, configuration 3⁴ was selected (CAS was 186kt; VFE = 185kt).

At about 1 150ft RA, during the LH turn to intercept the runway centerline, configuration FULL⁵ was selected (CAS was 170kt; VFE = 177kt) and within about one second, speedbrake lever was pushed aft to command extension. To do that, the crew disarmed the ground spoilers.

The F/O announced "High speed he" and immediately after "Let's circle again it's too high" followed by "High".



Slats and flaps surfaces reached the position FULL about 3s after the crew selected this configuration. Speedbrakes started to retract (speedbrakes are inhibited in configuration FULL on A320).

A Single Chime (SC) sounded, which corresponds to the "SPD BRK DISAGREE" caution, triggered because of the difference between the actual position of the speedbrakes (retracted) versus the commanded position (extended).

The speedbrake lever remained in the extended position until the end of recorded data. The ground spoilers were not rearmed.

The Captain then pushed the stick and increased the rate of descent up to 1 900ft/min.

At 600ft RA the EGPWS alarm "Sink Rate" triggered and sounded twice.

The Captain decreased the nose-down pitch from -6.5° to -2.5° . The aircraft rate of descent decreased.

At 500ft RA CAS was approximately 170kt (Vapp+ 32), and the rate of descent was about 1 800ft/min.

F/O said "Our speed is too high. We can make another circuit. How about that". The Captain continued the approach.

¹ Configuration 1: Slats 18° / Flaps 0°

² Configuration 2: Slats 22° / Flaps 15°

³ The wind information was not reliable because the wind indication system had been out of order for several months. A NOTAM had been issued, but the crew was not aware.



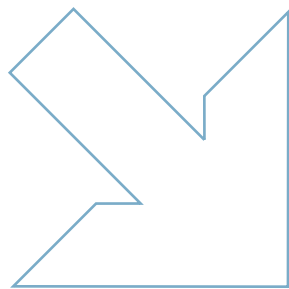

Landing

At 200ft RA the wind characteristics were: 11kt tailwind and 6kt crosswind from the left.

At 170ft RA, Autobrake MED was selected.

At about 150ft RA, the EGPWS alarm “Sink Rate” triggered and sounded twice.

The Captain pulled the stick and adjusted the pitch from -2.5° nose down to $+1^\circ$ nose up (reached at about 50ft). The aircraft rate of descent decreased.

At approximately 50ft RA, both thrust levers were retarded to idle. CAS was 159kt (Vapp + 21).

The aircraft flew over the runway 12 threshold, at a height of 35ft.

F/O called out “Speed”.

The aircraft floated above the runway during 9s and both main landing gears touched down at about 740m beyond the runway 12 threshold (1 226m of runway left), CAS was 150kt (Vapp+12). The aircraft bounced and touched down again at 1 070m beyond the runway threshold (896m of runway left). CAS was 146kt (Vapp+8), ground speed was 158kt.

Both brake pedals were fully pressed and the aircraft longitudinal deceleration reached 0.3g.

The thrust levers remained at idle and no reverser thrust was selected.

Note: Pressing the brake pedals normally deactivates the Autobrake. Here, the Autobrake did not activate since the ground spoilers did not deploy as they had been disarmed upon speedbrake selection. Ground spoilers, even disarmed, extend at touchdown at reverser thrust selection. However, as mentioned above, in this event reverser thrust was not selected.

⁴ Configuration 3 : Slats 22° / Flaps 20°

⁵ Configuration FULL: Slats 27° / Flaps 35°

⁶ Spoilers 2 to 4 act as speed brakes

Both brake pedals were kept pressed while Autobrake mode selection was changed to MAX.

This had no effect because the Autobrake was not activated.

The Captain then pulled full back stick and the thrust levers were set to TOGA for about 2s (while the aircraft was 316 meters from the runway end) and back to idle.

CAS was approximately 113kt.

The brake pedals were slightly released, and then were fully pressed again⁷.

The aircraft left the runway at a ground speed of approximately 85kt, crossed a field, descended a steep gradient and came to a stop in some trees.

3 | Key Points

- The aircraft was performing a visual approach to the 1 966m long runway 12, with A/P1 and both FD engaged.
- A/P was disconnected at 2 300ft RA.
- At about 1 200ft RA, during left final turn, configuration FULL was selected and immediately after, speed brake lever was pushed aft. This disarmed the ground spoilers.
- At 500ft RA, CAS was approximately 170kt (Vapp+32) and the rate of descent was about 1 800ft/min.
- The approach was never stabilized.
- The aircraft first touched down at 740m from the runway threshold (1 226m left), CAS was 150kt (Vapp+12).
- The second touch down occurred at about 1 070m from the runway threshold (896m left), CAS was 146kt (Vapp+8).
- Both thrust levers remained at idle. No thrust reverser was selected.
- The crew performed manual braking, deceleration rate reached 0.3g.
- The aircraft left the runway at about 85kt.

Note : With ground spoilers deployed at touch down without reversers, the aircraft would have stopped at about 350m before the runway end (400m if reversers had been selected).

⁷ Since CAPT and F/O brake pedals are mechanically linked, the DFDR does not allow to determine who actually pressed on the pedals.

4 | Lessons learned

4.1 Stabilized approach

The approach was never stabilized.

An unstabilized approach may result from an inappropriate evaluation of the situation and inadequate time management to plan, prepare and execute the approach.

This adequate preparation should be done through briefings, which are safety nets to ensure:

- Shared evaluation of the situation and setting of common objectives.
- A clear definition of the tasks and task sharing to be performed.
- A mutually agreed action plan, which includes preparing a go-around strategy if, for unexpected reasons, the approach has to be aborted.

During the approach, the crew should then monitor flight parameters and external conditions carefully in order to detect deviations from the planned approach, as even small deviations may lead to reduced safety margins.

FCOM 3.03.20 p.1, Visual Approach, indicates: *“Perform the approach on a nominal 3-degree glideslope using visual references. Approach to be stabilized by 500 feet AGL on the correct approach path, in the landing configuration, at VAPP.”*

4.2 Be go-around minded

The Flight Crew Training Manual 02.070 Approach Briefing reads as follows :

“The crew must be ready mentally for go-around at any stage of the approach. Should a failure occur above 1 000 ft RA, all ECAM actions (and DH amendment if required) should be completed before reaching 1 000 ft RA, otherwise a go-around should be initiated. This ensures proper task sharing for the remainder of the approach. Any alert generated below 1 000 ft should lead to a go-around.”

In addition, the Visual Approach SOP contained in FCOM 3.03.20 indicates :

“Have the aircraft stabilized by 500 feet AGL, on the correct approach path at VAPP (or ground speed mini) with the appropriate thrust applied. If not stabilized, a go-around should be considered.”

A go-around should be considered as well when confusion exists about :

- The use of automation
- The aircraft's response

4.3 Ground spoilers, thrust reversers and auto brake

The ground spoilers were disarmed when the crew selected the speed brakes.

At touch down, the PF did not select the reversers and the PNF did not check the ground spoilers extension nor the reversers deployment.

Airbus recommends adherence to the SOP in FCOM 3.03.22. p5/6. The touchdown procedures have been revised in June 2008 (REV 42) to include, among other modifications, notes reminding crews that:

- If ground spoilers are not armed, ground spoilers extend at reverser thrust selection on both engines.
- Autobrake is inhibited if the ground spoilers do not extend.

The revised touchdown procedures are shown hereafter:



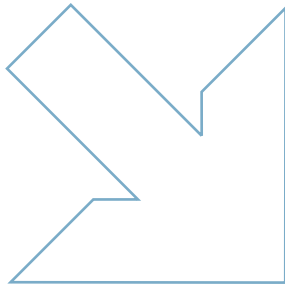

| | | | |
|--|---|---------|--------|
| A318/319/320/321 <small>FLIGHT CREW OPERATING MANUAL</small> | STANDARD OPERATING PROCEDURES LANDING | 3.03.22 | P 5 |
| | | SEQ 001 | REV 42 |

● **At touchdown :**

– **REV MAX**

- Select MAX REV immediately after the main landing gear touches down.
If the airport regulations restrict the use of thrust reversers, select and maintain the thrust levers in reverse idle position until taxi speed is reached.
A slight pitch up that can be easily controlled by the pilot, may occur when the thrust reversers are deployed before the nose landing gear touches down.
Lower the nosewheel without undue delay.
- The PNF continues to monitor the attitude.
- In the case of an engine failure, the use of the remaining thrust reverser is recommended.
- Braking may begin before the nosewheel has touched down, if required for performance reasons. However, when comfort is the priority, the flight crew should delay braking until the nosewheel has touched down.
During rollout, the flight crew should avoid sidestick inputs (either lateral or longitudinal).
If directional control problems are encountered, the flight crew should reduce thrust to reverse idle until directional control is satisfactory.
- After reverse thrust is selected, the flight crew must perform a full stop landing.

R – **GROUND SPOILERS CHECK/ANNOUNCE**

- R Check that the ECAM WHEEL page displays the ground spoilers extended after
R touchdown.
R · If no ground spoilers are extended :
R – Verify and confirm that both thrust levers are set to IDLE or REV detent
R – Set both thrust reverser levers to REV MAX, and fully press the brake pedals.

R *Note : If ground spoilers are not armed, ground spoilers extend at reverser thrust*
R *selection.*

R – **REVERSERS CHECK/ANNOUNCE**

- R Check that the ECAM E/WD page displays that the reverse deployment is as
R expected (REV green).

– **DIRECTIONAL CONTROL ENSURE**

- Use rudder pedals for directional control.
- Do not use the nosewheel steering control handle before reaching taxi speed.

– **BRAKES AS RQRD**

- Monitor the autobrake, if it is on. When required, brake with the pedals.
- Although the green hydraulic system supplies the braking system, if pedals are pressed rapidly, a brake pressure indication appears briefly on the BRAKE PRESS indicator.

R *Note : If no ground spoilers are extended, the autobrake is not activated.*

| | | | |
|--|--------------------------------------|---------|--------|
| A318/319/320/321 <small>FLIGHT CREW OPERATING MANUAL</small> | STANDARD OPERATING PROCEDURES | 3.03.22 | P 6 |
| | LANDING | SEQ 001 | REV 42 |

- R **– DECELERATION** **CHECK/ANNOUNCE**
 R The deceleration is felt by the flight crew, and confirmed by the speed trend on the
 R PFD.
 R The deceleration may also be confirmed by the DECEL light (if autobrake is on).

5 | Conclusion

This event illustrates the need to prepare each approach and to perform an adequate briefing, which will help the crews in:

- The execution of a stabilized approach
- The recognition of the need to carry out a timely go-around
- The performance of a safe go-around

Runway excursions remains a major category of incidents and accidents.

Avoiding them requires following two golden rules :

- Fly stabilized approaches
- Be go-around minded

This message is essential as insufficient preparation of the approach and/or minor deviations in the flight path may result in major safety consequences.

Airbus also recommends giving consideration to the Flight Operation Briefing Notes (FOBNI) “Flying Stabilized Approach”, FOBNI “Descent and Approach Profile Management” and FOBNI “Aircraft Energy Management during Approach”.

The Flight Operation Briefing Notes are available on the Airbus website at the following address and can be downloaded at:

http://www.airbus.com/en/corporate/ethics/safety_lib/



FCTL check after EFCS reset on ground

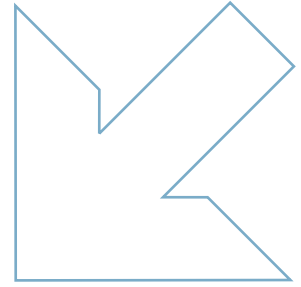

By: Kristjof TRITSCHLER
Flight Safety Manager
Germanwings



Albert URDIROZ
Flight Safety Director
Airbus

1 | Introduction

Recently, an A320 operated by Germanwings experienced an uncommanded spoiler extension in flight.

On review of this event, the authors felt it was worth writing an article to describe the sequence of events that led to this occurrence, and to highlight the

need to repeat the Flight Control Check after resetting of an EFCS system computer.

Readers interested in the subject may wish to read the paper titled “The importance of the pre-flight Flight Control Check” published in issue #01, dated January 2005, of this magazine.



2 | Spoiler fault capture

The aircraft was dispatched with a LH spoiler actuator #5 in faulty condition.

When the crew taxied the airplane, the spoiler anomaly was captured during the pre-flight control checks.

The crew performed roll inputs with the sidesticks and the SEC detected the lack of response of LH spoiler 5 by monitoring the difference between the

order given and the position of the spoiler. The EFCS computer SEC2, that controls spoilers 5, disabled the two spoilers 5 as a pair.

F/CTL SPOILER FAULT was triggered, and spoiler shown as FAULT RETRACTED (5) on the ECAM F/CTL page.

Figure 1 illustrates the messages displayed on the F/CTL page of their ECAM.

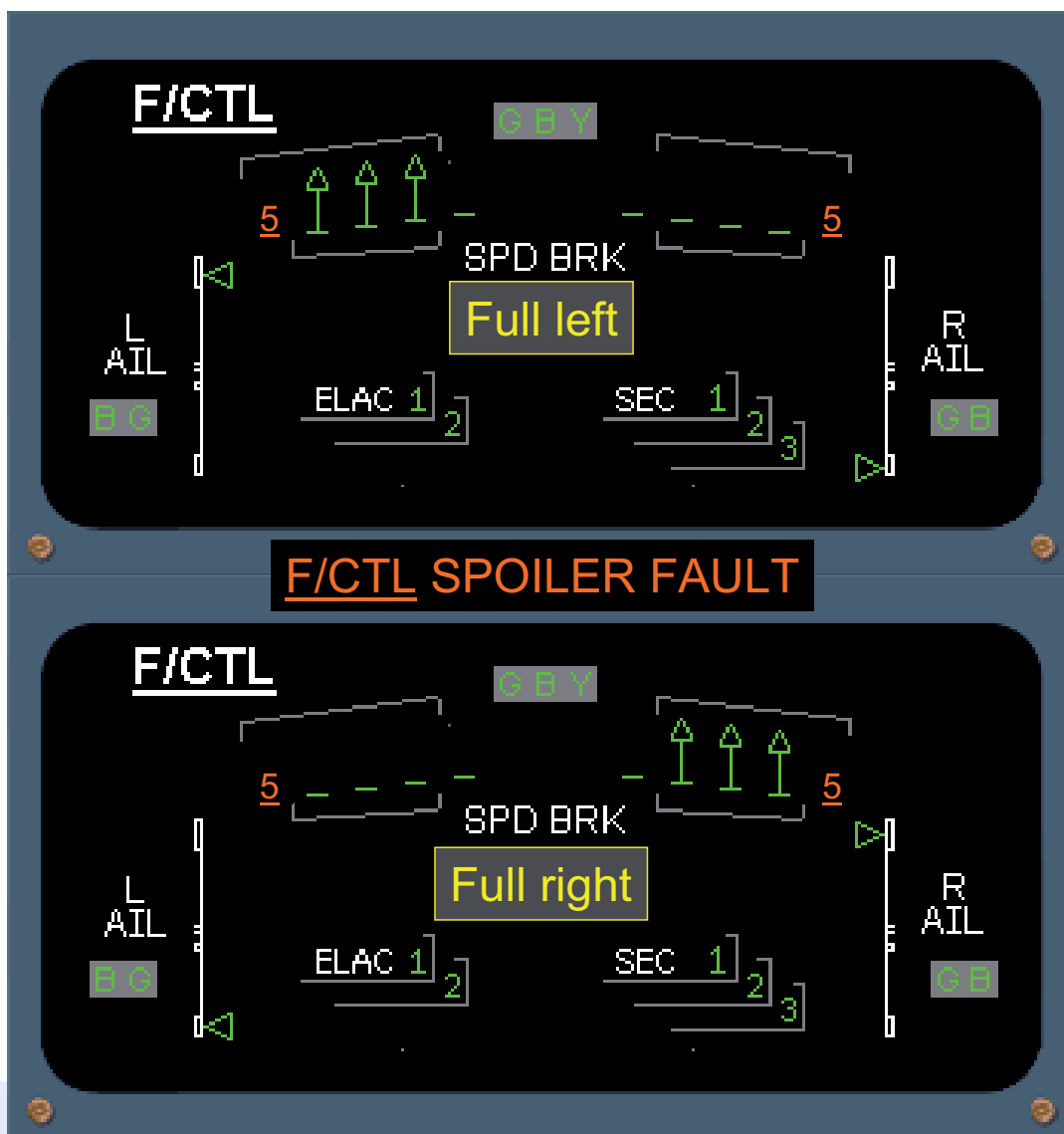
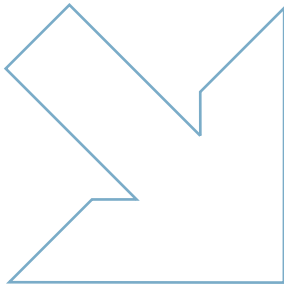

Figure 1: Spoiler 5 fault during F/CTL check





3 | SEC reset

The crew reset the SEC in an attempt to recover control of spoilers 5.
As a result, ECAM indications went back to normal,

i.e. F/CTL SPOILER FAULT cleared and spoilers 5 were displayed back to GREEN on the F/CTL page (fig.2).

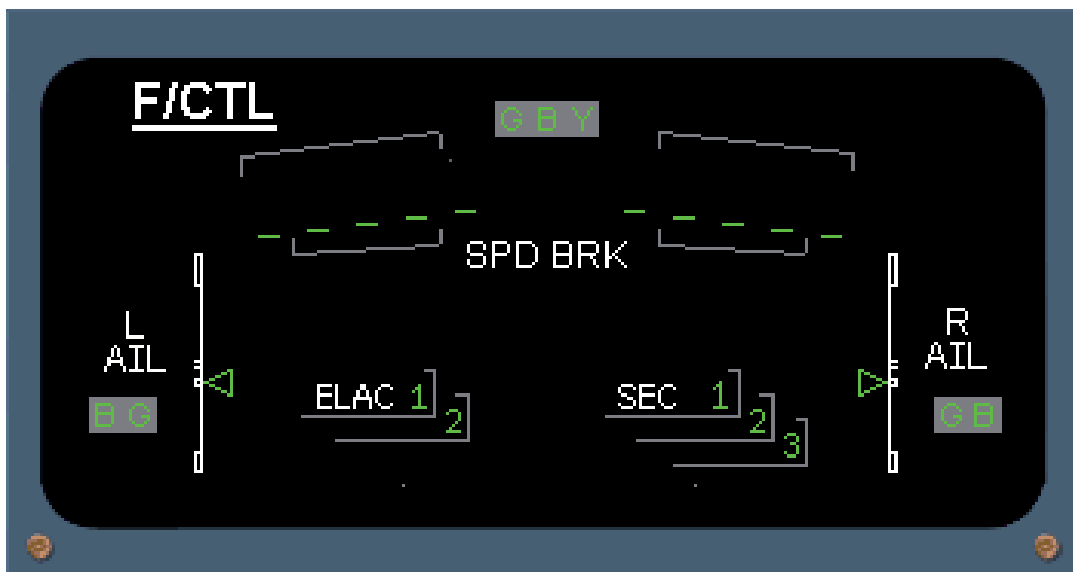

Figure 2: All GREEN after SEC reset

Considering that the systems status was back to normal, the crew then resumed the flight sequence.

4 | Consequence of the SEC reset

Through the SEC reset, the monitoring system of the spoilers was reinitialized and this cleared the fault message. The faulty condition, however, remained.

The capture by the monitoring system, based on the difference between given order and position of the flight control, would have required a second flight control check.

Had the crew performed a new flight controls check after the SEC reset, the same spoiler fault ECAM warning would have popped up again.

As the flight resumed, aerodynamic forces extended the faulty LH spoiler, forcing the flight crew to counteract the LH roll tendency.

The ECAM warning SPOILER FAULT did not appear during the take-off run, nor during the early climb, as it is inhibited in phases 3 to 5 (from take-off thrust application to 1 500 feet).

Once in level flight, recordings indicate that about 4° of RH rudder trim was necessary to compensate for the uncommanded spoiler extension. The crew was able to fly to its original destination.

5 | FCOM improvement

In order to stress the need to perform a Flight Control Check **after** the resetting on ground of the EFCS, it was decided to add a note in the “ELAC or SEC malfunction” part of the 3.04.24 Computer Reset Table (P5).

On the A320 family program, TR reference 105-1 was issued in June 2007 (*fig. 3*).

A similar TR reference 568-1 was issued for the QRH 2.38.

These TR have been incorporated in the June 2008 revisions (REV 42) of the A320 family FCOM and QRH.

On the A310/A300-600 and A330/340 programs the note had already been incorporated in their respective FCOM and QRH.

On the A310/300-600, the note concerns the EFCU reset, which controls the spoilers electrically.

Note: The A380 is, as of today, not concerned by this issue, as FCTL system resets are not authorized.

| | | | |
|----|-------------------------|-------------|--|
| 27 | ELAC or SEC malfunction | ELAC or SEC | <p>WARNING : Do not reset more than one computer at a time.</p> <ul style="list-style-type: none"> · It is possible to reset flight control computers in flight, event if not requested by the ECAM, provided only one reset is performed at a time: For the ELAC only, in case of uncommanded maneuvers during the flight, it is not recommended to reset the ELAC. <p>Note :</p> <ul style="list-style-type: none"> · <i>When an ELAC reset is performed on ground the crew must check the pitch trim position.</i> · <i>If a reset is performed on ground, the flight crew must then perform a flight control check, as per SOP.</i> |
|----|-------------------------|-------------|--|

*Figure 3:
Extract of TR 105-1*

6 | Conclusions

This incident, fortunately, did not have any major operational consequence.

It illustrates, however, the message that the authors wish to highlight:

If a reset of an EFCS or EFCU computer is performed on ground, it must be followed by a flight control check

Airbus wishes to thank Kristjof Tritschler and Germanwings for their contribution to this article.



A320/ Possible consequences of VMO/MMO exceedance



By: Michel PALOMEQUE

*A320 Flight Safety Director & Chief Engineer Advisor
A320 Program*

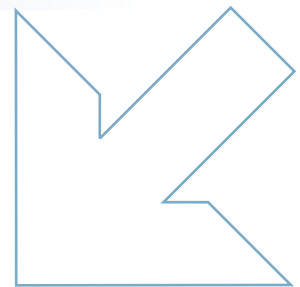

1 | Introduction

This article is a follow up on a presentation given at the last Flight Safety Conference in Barcelona on October 2007.

It describes the solutions, which have been developed and implemented in the latest ELAC L84 and L93 software standards in order to assist the crews in avoiding large altitude incursions linked to VMO/MMO exceedance scenarios.

It will describe as well the modifications brought to the last standards of the Flight Warning Computer In order to improve pilot awareness in case of Auto Pilot disconnection.

2 | Description of two possible scenarios

VMO/MMO exceedance events usually happen in cruise or during descent, when the aircraft encounters a significant wind gradient.

The aircraft typically has the Auto Pilot engaged, and the wind gradient will lead it to exceed the High Speed protection (HSP) threshold (the speed or Mach number at which the HSP activates depend on the flight conditions, but do not exceed $VMO+6kt$ or $MMO+0.015$). The triggering of the HSP will automatically disconnect the Auto Pilot.

2.1 First scenario : no pilot input following AP disconnection

If the side stick is free, HSP activation will automatically add a small positive G demand until the aircraft returns within the flight envelope.

From experience, the altitude excursion is limited to less than 700 ft (*fig. 1*).

2.2 Second scenario : strong pilot input following AP disconnection

If the pilot reacts to the over speed by pulling too strongly on the side stick (in which case the pilot input will be added to the HSP input), the Angle Of Attack (AOA) protection may be triggered.

This means that the aircraft will climb at the highest AOA value for as long as the protection is activated. Since deactivation may only be achieved through nose down side stick input, simply releasing the stick will not stop the climb.

Delayed reaction from pilots in applying forward stick input results in large altitude excursions (*fig. 2*).

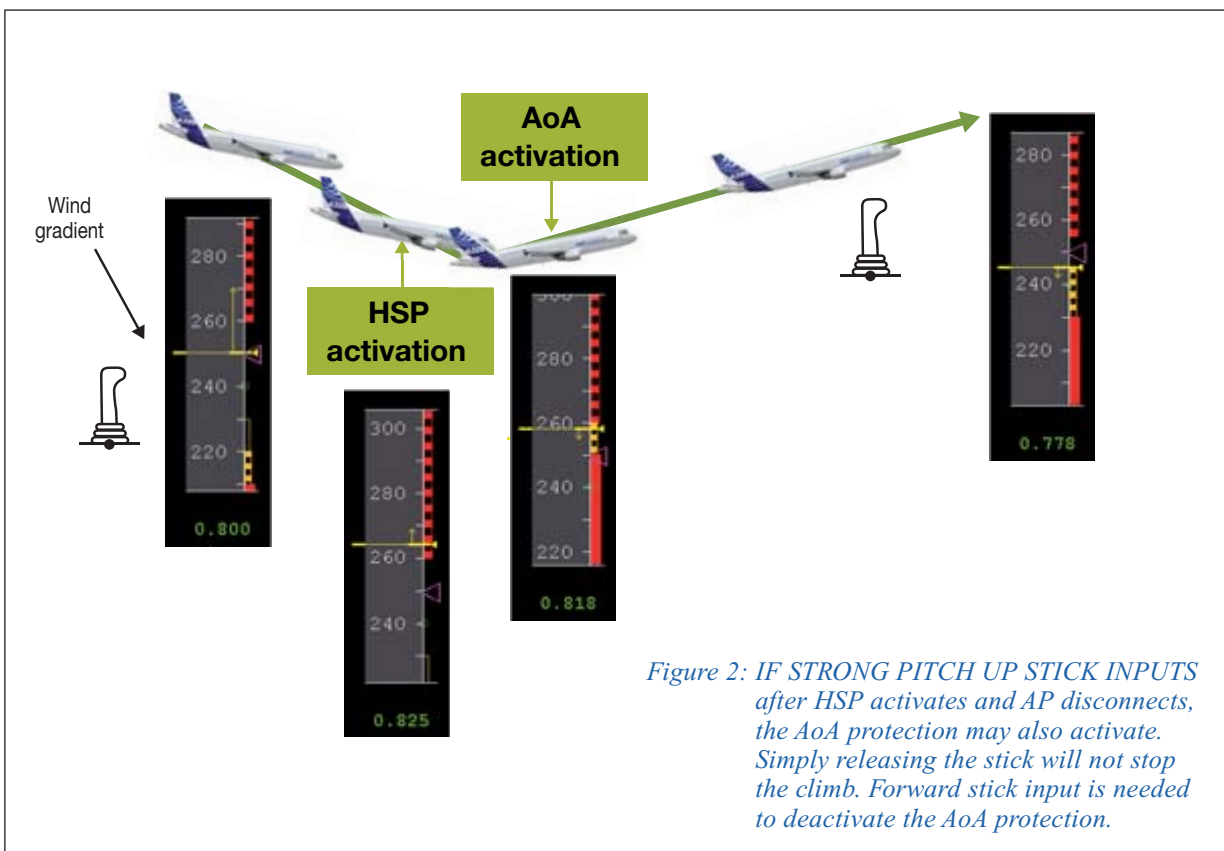
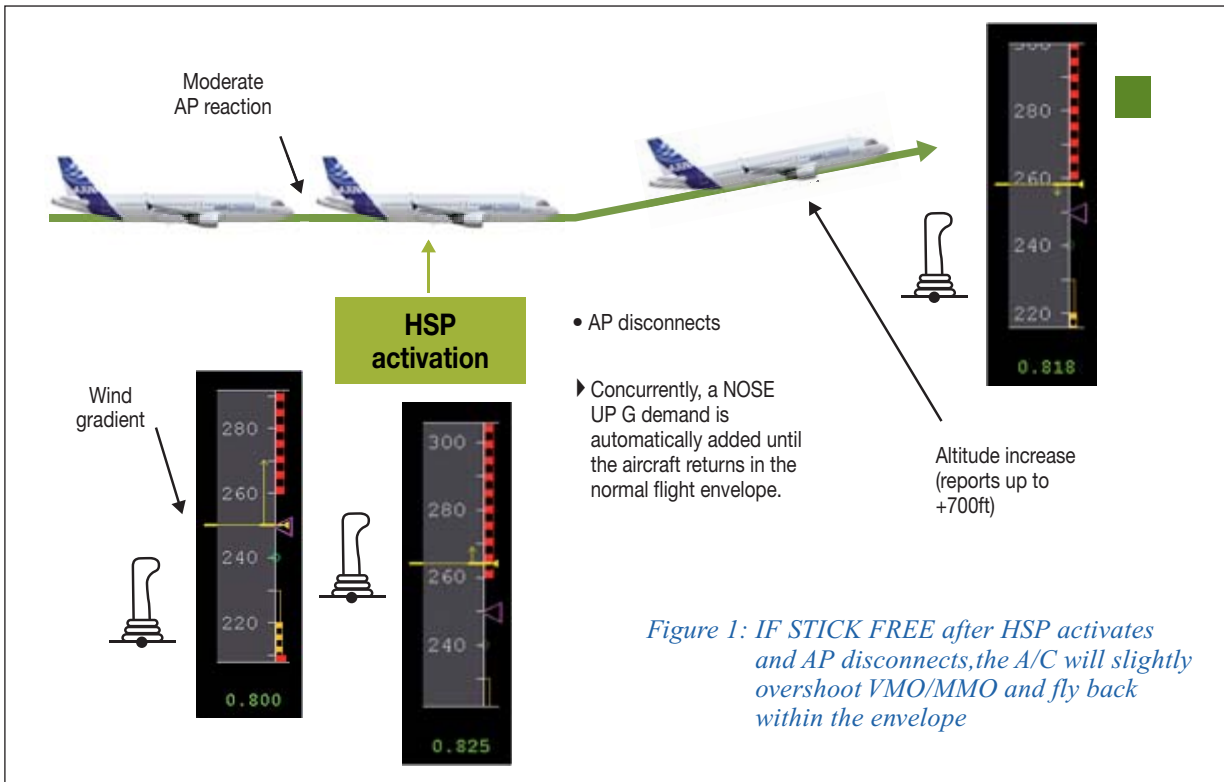

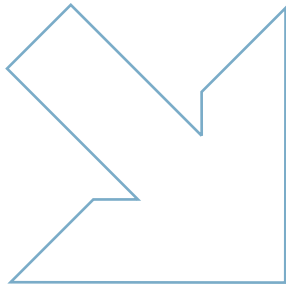

3 | HSP activation/ AP disconnection logics change implemented in ELAC L84 and L93

As indicated above, HSP activation disconnects the AP.

In order to avoid the above type of scenario, it was decided to:

- Introduce a 3 second filter to avoid AP disconnection in case of very short overspeed situations
- Increase the HSP activation threshold so as to keep the benefit of the Auto Pilot at higher speeds and Mach numbers.

3.1 New speed threshold for HSP activation/AP disconnection

| L83/L91 standards | L84/L93 standards |
|-------------------|--------------------------|
| 356 kt | 365 kt (3 second filter) |

In the L84/L93 standards, a 3 second filter has been introduced and the speed threshold has been increased by 9 kt.

3.2 New Mach threshold for HSP activation/AP disconnection

| L83/L91 standards | | L84/L93 standards |
|----------------------------|--|--|
| A319/ A320 | M. 83 | Flight Path Angle dependant MMO threshold + 0.01 (3 second filter) |
| A318/ A321 ¹ | M.83 (3 second filter) M.86 (no filter) | |

In the L84/L93 standards, the Mach threshold is a function of the Flight Path Angle and is identical for the whole A320 family. The main aim is to have a better protection of the aircraft during cruise (*fig. 3*).

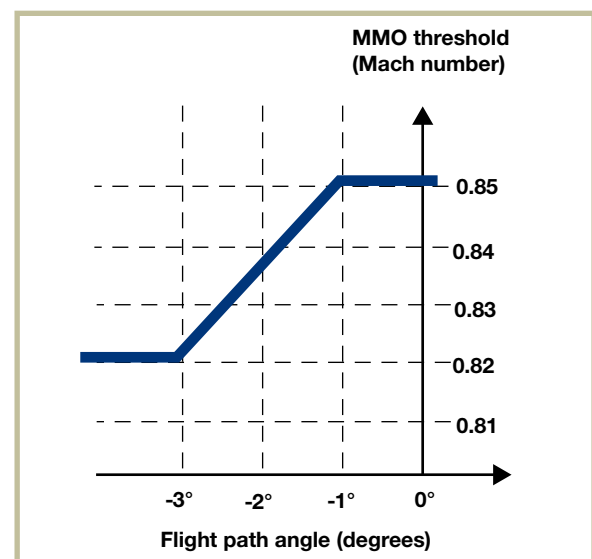

Figure 3: L84/L93 Mach threshold for HSP activation/AP disconnection.

| ELAC hardware | ELAC software | Mod. number | Service Bulletin |
|---------------|---------------|--------------------|-------------------|
| A or A' | L84 standard | 38105 ² | Not yet available |
| B | L93 standard | 38008 ² | 27-1182 |

¹This L83/L91 standards logic is limited to the A318/A321 because of A319/A321 compability issues with previous standards

² Activation of VMO/MMO protection function through hard pin program Mod. n° 38298, SB n° 27-1183

4 | AP disconnection unawareness

With the old FWC standards, the VMO/MMO OVERSPEED aural warning (continuous repetitive chime) may supersede the AP disconnection aural warning (cavalry charge).

The overspeed warning is activated at VMO+4kt or MMO+0.006 i.e. before the activation of the HSP, and hence disconnection of the AP

The following has been reported: upon activation of the VMO/MMO OVERSPEED warning, a crew member had pressed the Master Warning pushbutton, thereby cancelling the AP disconnection aural warning, even though it had not yet been generated (since it was superseded by the overspeed warning). This may lead to situations where the pilots are unaware of the AP disconnection.

Note: AP disconnection will lead as well to the generation of an AUTO FLT AP OFF alert message on the ECAM, which cannot be cleared through the Master Warning pushbutton.

The logics for the cancellation of the VMO/MMO OVERSPEED and AP disconnection warnings are as follows :

- VMO/MMO Overspeed warning cancellation:
 - Whatever the FWC standard, a Continuous Repetitive Chime (CRC) cannot be cleared by an action on the Master Warning P/B.
- AP disconnection caution cancellation:
 - Old FWC standards (H1E2, H2E2):
The Cavalry charge may be cancelled by an action on the Master Warning even if not yet generated (hidden by CRC).
 - Newer FWC standards (H1E3, H2E3, H2E4, H2F2, H2F3):
The cavalry charge can only be cancelled if generated.

5 | Conclusion

In order to avoid significant altitude excursions and AP disconnection unawareness in case of VMO/MMO exceedance, Airbus recommends installation of :

- Standards L84 or L93 of the ELAC
- Standards H1E3 or H2E3, H2E4, H2F2, H2F3 of the FWC.



A320/ Prevention of tailstrikes

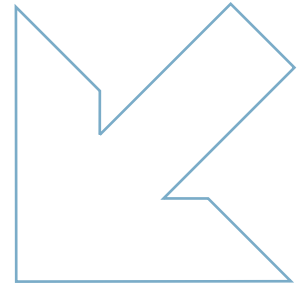

By: Michel PALOMEQUE

*A320 Flight Safety Director & Chief Engineer Advisor
A320 Program*

1 | Introduction

Like the preceding paper on VMO/MMO exceedance, this article is a follow up on the presentation titled "A320 ELAC" given at the last Flight Safety Conference in Barcelona on October 2007.

It will look as well at the safety improvements brought to the ELAC in the form of the latest L84 and L93 standards, which bring additional prevention means against tailstrikes during landing. Two other modifications will also be described, concerning the pilot awareness of a too high pitch in the landing phase.

2 | Description of typical tailstrike scenario

Most of the tailstrikes on A320 family aircraft occur during landing in manual mode (Auto Pilot OFF), when the sidestick is maintained in the aft position after touch down (Fig1).

The importance of this subject is obviously correlated to the fuselage length. It is, therefore, particularly important to A320 and A321 operators.

| | A318 | A319 | A320 | A321 |
|--|-------|-------|-------|-------|
| Pitch attitude limit with MLG fully compressed | 15.7° | 13.9° | 11.7° | 9.7° |
| Pitch attitude limit with MLG fully extended | 17.3° | 15.5° | 13.5° | 11.2° |

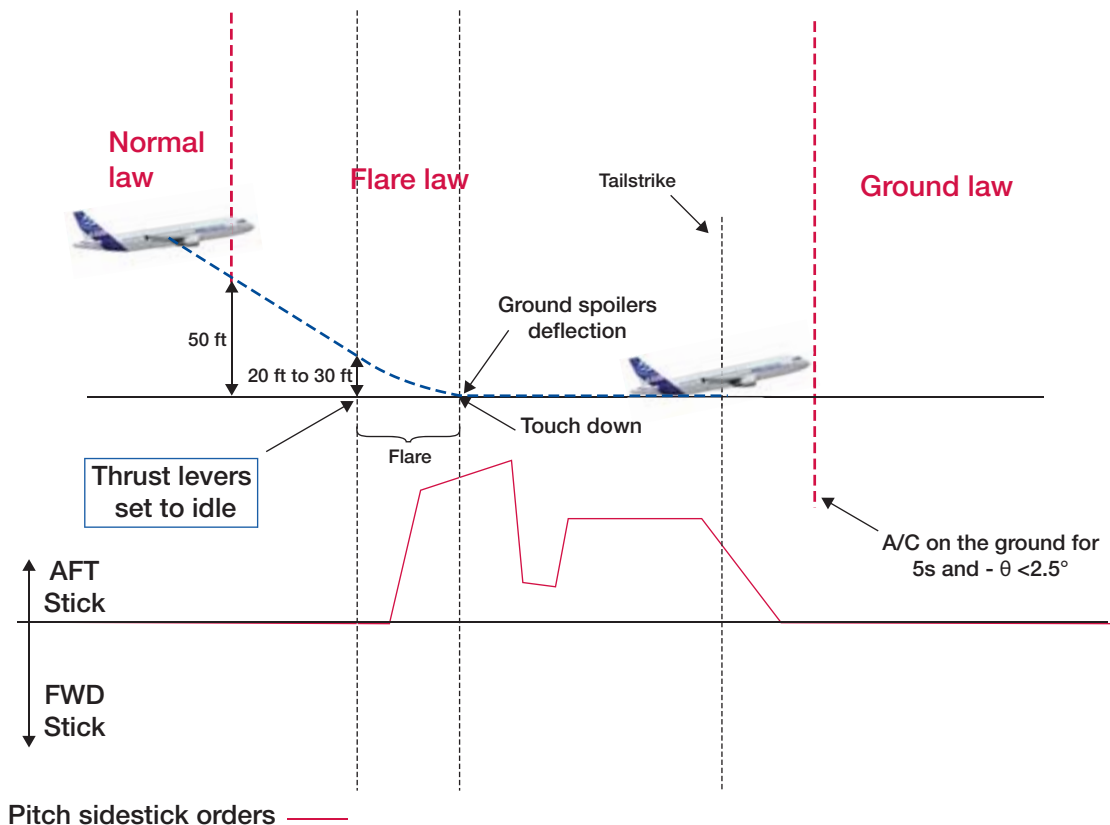

Figure 1: Normal landing with sidestick maintained AFT after the touch down.

3 | Flight control law improvement

In order to avoid the above scenario, it was decided to improve the flare law of the flight control law of the A320 and A321. This was done by introducing a limitation of the side stick nose up inputs during landing.

3.1 Flare law before L84 and L93 standards

The principle is as follows:

- A pitch sidestick deflection corresponds to a commanded pitch attitude.
- The maximum commanded pitch attitude with full back stick is 18 degrees (fig. 2).

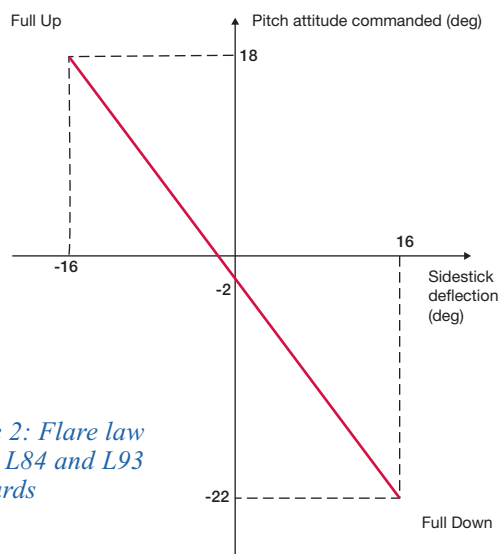
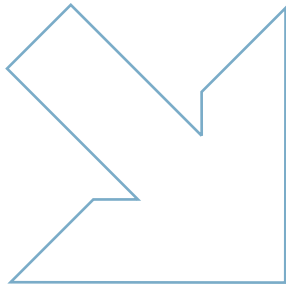

Figure 2: Flare law before L84 and L93 standards





3.2 Flare law in L84 and L93 standards

With the new law introduced in the latest ELAC standards (*fig. 3*), the maximum commanded pitch attitude on ground is limited to the values indicated in the table below:

| Pitch rate change | | |
|-------------------|--------|-------|
| | < 3°/s | >3°/s |
| A320 | 9° | 6° |
| A321 | 7° | 4° |

This limitation is triggered by the ground spoiler extension, thus ensuring that it will be active only during landing. It is therefore deactivated during the take off and go-around phases.

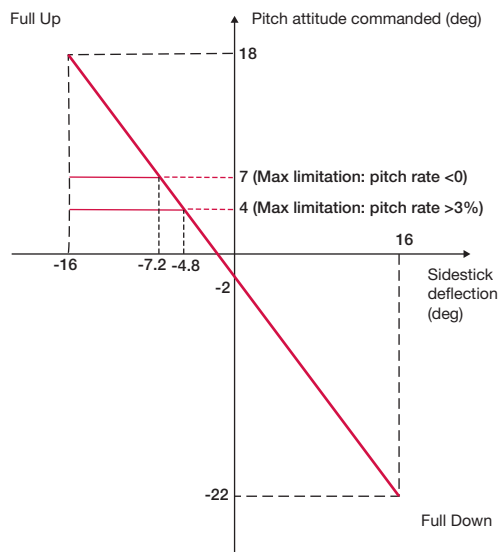

Simulations with the improved control laws have confirmed the following:

- No impact on the landing performance
- The usual flare is not modified
- No interference in case of go-around or during take off due to the ground spoiler condition

Figure 3: A321 pitch attitude control law on ground

| ELAC hardware | ELAC software | Mod. number | Service Bulletin |
|---------------|---------------|-------------|-------------------|
| A or A' | L84 standard | 38105 | Not yet available |
| B | L93 standard | 38008 | 27-1182 |

4 | Additional alerts to impending tailstrike

In order to further increase pilot awareness to an impending tailstrike, the following modifications have been developed for the A320 and A321:

- A pitch limit indicator on the Primary Flight Display, which is displayed at landing (below 400 feet AGL in both manual and automatic modes) when the thrust levers are below the FLEX/MCT setting.

Note: due to the below FLEX/MCT condition, the pitch limit indicator is not displayed during the T/O phase.

(This modification is available only for aircraft with the EIS2 standard)

- A “PITCH, PITCH” call out, activated when the pitch is greater than a certain threshold and if TOGA is not selected.

(The call out is available on the following standards : FWC H2F3 or H2F3P and FAC 618 or 619).

| | | Mod. number | Service Bulletin |
|-------------------------------|-------------------------------------|----------------|------------------------------|
| Pitch limit indicator on PFD | Activation (only on A320/A321) | 37444 | No std SB RFC/RMO process |
| | EIS2 S7 standard | 36725 | 31-1276 or 31-1271 |
| “Pitch, Pitch” audio call-out | Activation (only on A320/A321) | 37445 | No std SB RFC/RMO process |
| | FAC 618 standard | 35522 | 22-1226 |
| | 619 standard | 36766 | 22-1226 |
| | FWC H2F3 standard H2F3P standard | 35220 38425 | 31-1267 31-1300 |

5 | Conclusion

In order to avoid excessive pitch up demand at landing when on ground, the ELAC flight control laws have been enhanced in the new ELAC L84 and L93 standards.

Associated to this modification, a pitch limit indicator on the PFD and a “PITCH, PITCH” call out have been developed, to further increase pilot awareness. We are confident that these modifications will help to minimize the number of tailstrikes during landing.



Low fuel situations awareness



By: Frédéric MARANI

*Manager, Safety Strategy Development
Product Integrity*

1 | Introduction

One easily understands that lack of fuel may seriously impair the safety of a flight.

Monitoring the fuel status all along a mission is therefore one of the critical tasks of the crew. The challenge of this monitoring is that fuel status may be adversely affected by a very wide variety of factors. This article will briefly review the factors affecting fuel status, and will then stress :

- The importance of fuel checks, developed to ensure timely detection of a low fuel situation
- The limits in the use of the FMS in Fuel On Board projections under degraded conditions

This article is a complement to the presentation titled “Detecting and managing situations of low usable fuel” given during the 14th Flight Safety Conference in Barcelona on October 2007.

2 | Fuel status variables

The factors affecting the fuel status may be sorted out in two classes.

- Those linked with the operating context such as :
 - Delays induced by ground operations factors at departure airport

- Air Traffic Control constraints modifying the scheduled flight plan
- Meteorological factors
- Congestion at the destination airport leading to holding or diverting.

- And those linked with the aircraft like :
 - Airplane ageing: mainly the engines, but also the airframe and nacelles
 - Airplane flying under conditions of the Minimum Equipment List (MEL) or Configuration Deviation List (CDL)
 - Aircraft speed not in accordance with the scheduled flight plan
 - Overweight compared to flight plan but also
 - In-flight failures with an effect on fuel consumption
 - In-flight failures with an effect on the fuel available for the mission (e.g. fuel leaks leading to fuel being trapped).

3 | Standard Operating Procedures (SOPs)

Because of the variety of causes that may lead to a low fuel situation, and in view of the configuration of the fuel system, several means must be used to maximise the chance of an early detection.

According to the SOPs for the cruise phase, 3 types of check have to be performed when over flying a waypoint, or every 30 minutes:

1. Fuel On Board
2. FMS Fuel prediction
3. Fuel On Board/Fuel Used

The above checks need to be performed as well each time a FUEL IMBALANCE procedure is necessary, and they should be performed before applying the Fuel Imbalance procedure.

Note: On the A300-600/A310/A320family/ A330/A340 and A380 aircraft, FUEL IMBALANCE detection is available as an "advisory" message associated with the Fuel System page on the System Display. On the A340-500/600 and A380, it triggers as well an amber caution appearing on the ECAM. No such alarm is available on the A320 family for the time being.

3.1 First check: Fuel On Board

Cruise SOP FCOM 3.03.15 P1 (SA/LR) FCOM 2.03.15 P1 (WB)¹ :

"Check Fuel on Board (ECAM)... and compare with the computer flight plan or the FCOM In-Cruise Quick-Check Table."

Any marked difference in FOB quantity compared to the flight plan prediction may reveal either:

- A fuel over-burn, which may be explained by:
 - Some significant deviations from the initial flight plan, due for instance to restrictions from Air Traffic Control, degradations of meteorological conditions, engine failure
 - An airplane configuration degradation, due for instance to an aerodynamic drag increase coming from flight control surfaces permanently deflected, a landing gear or gear doors partially extended, ice accretion.
- An external fuel leakage

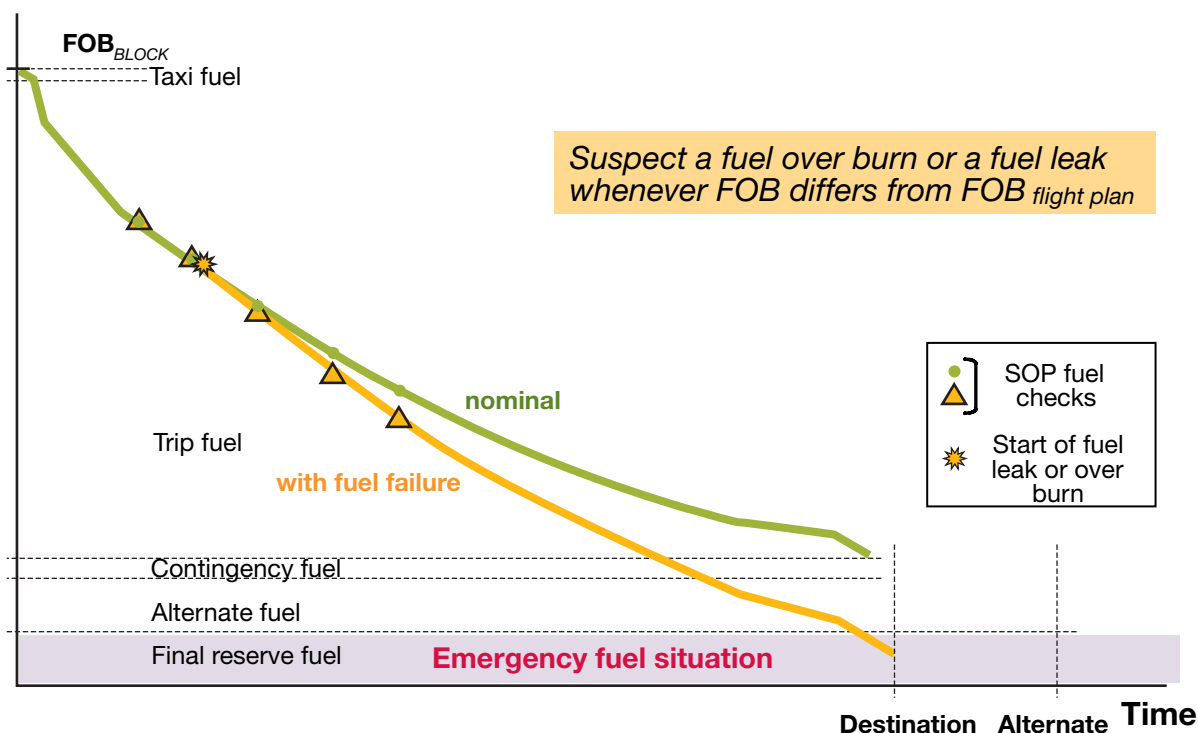

¹ SA: Single Aisle : A318/A319/A320/A321

LR: Long Range : A330/A340

WB: Wide Body : A300/A310

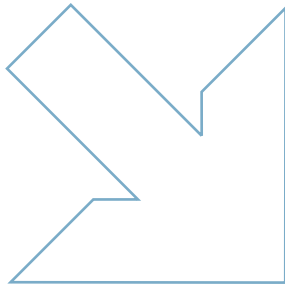

3.2 Second check: FMS Fuel prediction

Cruise SOP FCOM 3.03.15 P1 (SA/LR) FCOM 2.03.15 P1 (WB):

“Check... fuel prediction (FMGC) and compare to the computer flight plan or the FCOM In-Cruise Quick-Check Table.”

The FMS is able to make FOB predictions at point along the flight plan: waypoints, destination (DEST EFOB) or alternates. It considers the entered flight plan and assumes a nominal aircraft (potentially customized to monitored performance level through individual PERF factor) i.e. without failure.

It is updated permanently from the measured FOB and from modifications of the flight plan entered into the FMS, if any. In nominal conditions, without flight plan update, DEST EFOB should not show any marked evolution throughout the flight.

Hence, in case of fuel over-burn due, for instance, to a drag increase, DEST EFOB will decrease permanently at the same rate the actual FOB is drifting away from the initial flight plan prediction. The same behaviour would happen for a fuel leak.

Important note:

FMS prediction is a projection of actual FOB that never takes into account any degraded state of the aircraft, even when due to a failure that is monitored and shown on the cockpit panel or ECAM displays.

This rule has only one exception: engine failure, once confirmed in the FMS.

Decreasing DEST EFOB indication is a sign of degrading fuel situation.

For the above-mentioned reasons, it also means that the displayed DEST EFOB value cannot be used to anticipate the fuel status at destination. The same is true for all other EFOB projections, like at waypoints or alternates.

Note: DEST EFOB displayed on FMS pages turn to amber if it becomes lower than the sum of Alternate and Final reserves fuel entered in the FMS: it indicates that contingency fuel and extra fuel reserves are no more available.

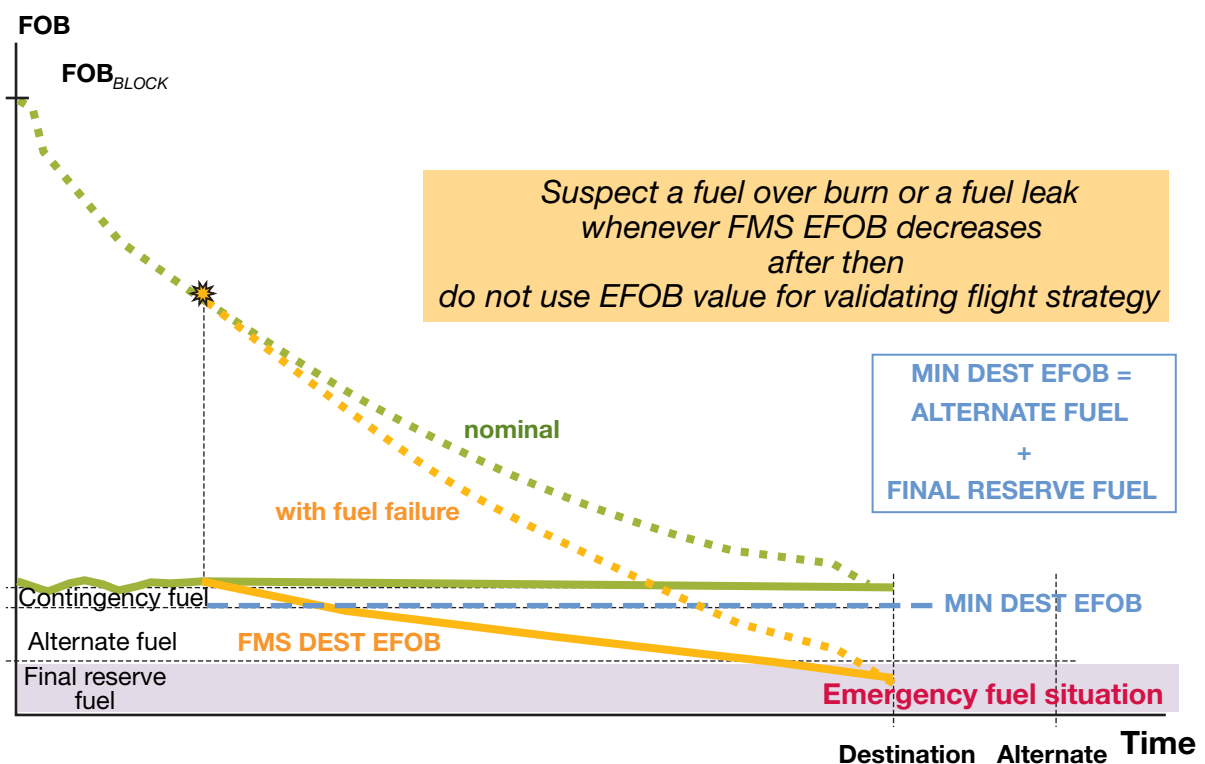

3.3 Third check: Fuel On Board/Fuel Used

Cruise SOP FCOM 3.03.15 P1 (SA/LR) FCOM 2.03.15 P1 (WB):

"Check that the sum of the Fuel On Board and the Fuel Used is consistent with the Fuel On Board at departure... If the sum is either unusually smaller than the FOB at departure, or if it decreases, suspect a fuel leak."

A higher sum may provide the indication of a frozen fuel quantity parameter leading to a wrong FOB data.

Note: The amber caution F. USED/FOB DISAGREE exists basically on the A340-500/600 and A380. On the A330 and A340-200/300, they have to be activated, provided the aircraft are equipped with the following minimum standards: FCMC 9.0 and FWC K5-5 (A330) or L8-0 (A340). This caution does not replace the SOP check, but may allow an earlier detection of a fuel leak.

Important note:

A fuel leak downstream of the Flow Meter will not be detected through this check. It will, however, be revealed through an excessive fuel flow on one of the engines.

Indeed, an unexpected engine fuel flow level may be caused by:

- A fuel leak, downstream of the Flow Meter, sometimes confirmed by:
 - Fuel spray visible from the cabin coming from engine or pylon
 - Fuel smell in the cabin
- But also a fuel over-burn associated with a failure impacting the aircraft aerodynamics or engine performance with the following possible indications:
 - Step or steep increase of engine control parameter
 - Difficulty to maintain ceiling or Mach number
 - Time or distance increase during step climbs
 - Aircraft asymmetry along roll or yaw axis visible sometimes only through compensation by control surfaces
 - Noise, buffet vibrations.

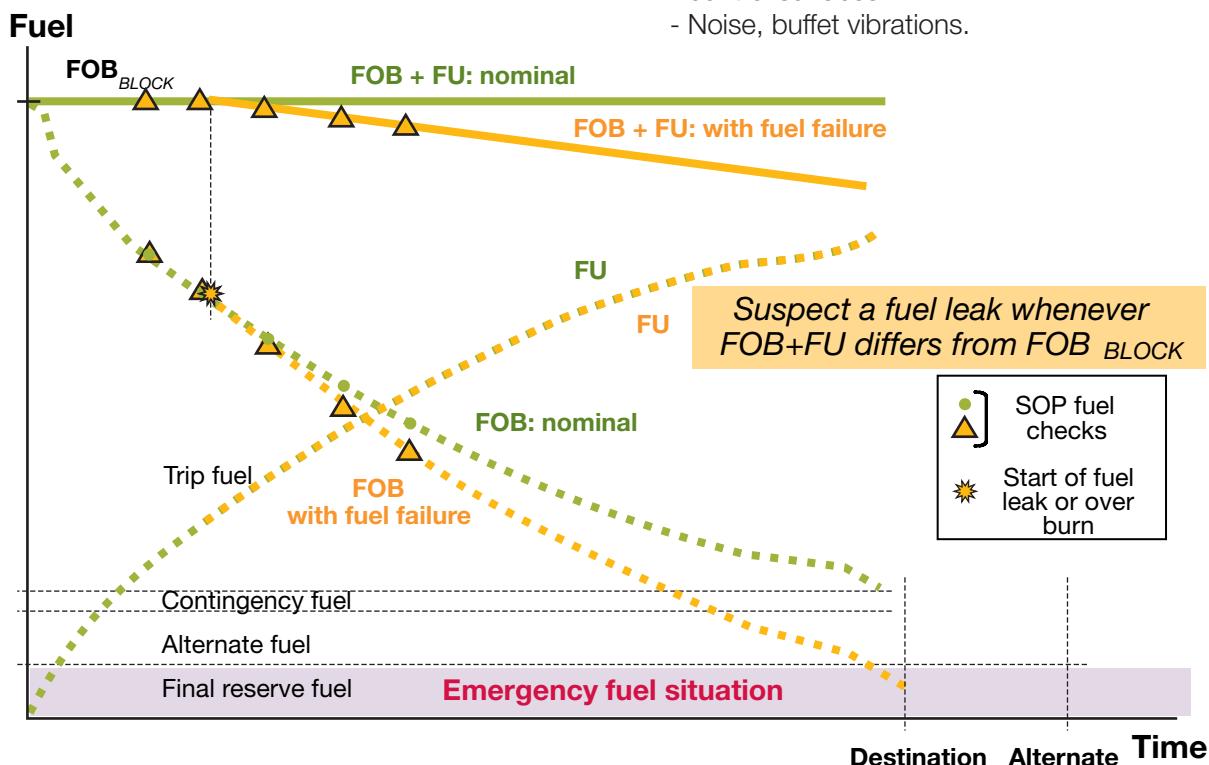

4 | Fuel On Board versus available fuel

The three checks described above all assume that the FOB is available to fly the aircraft. This may not always be the case as some fuel may be trapped or transferring too slowly due to an anomaly in the transfer sequence such as :

- Non operating transfer device (blocked or clogged transfer valve etc...)
- Ruptured or cracked transfer line in a fuel tank.

These situations may be detected through :

- A faulty equipment message on the Fuel page of the System Display
- A developing fuel imbalance when one of the wing tanks is affected
- A deviation in the fuel transfer sequence.

5 | Conclusion

The FOB, Fuel prediction and FOB/FU checks in cruise provide powerful means for detecting an abnormal fuel situation. These checks, included in the cruise phase SOPs, should be adhered to without exceeding the indicated interval of 30 minutes.

These checks should be performed as well after detection of an abnormal fuel status.

They will allow, after the corrective measures have been taken, to ensure that the procedures applied have reached the expected results.

It is also important to bear in mind that:

- FMS EFOB predictions do not take into account non-nominal aircraft conditions (except engine failures once confirmed in the FMS) and have to be corrected to take into account the consequences of excessive fuel consumption or fuel leaks.
- FOB/FU checks will not detect fuel leaks or excessive fuel burn downstream of the Flow Meter and should therefore be complemented by engine fuel flow checks.

With the rising price of fuel, there is a high chance for extra fuel reserves to be more and more challenged: in this evolving context, it is certainly worth developing crew awareness in terms of fuel monitoring to maintain a high level of safety in aircraft operation.



Rudder Pedal Jam

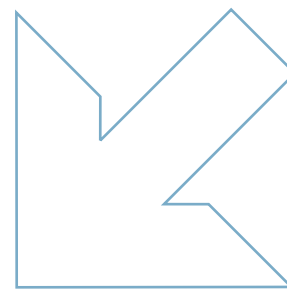

By: Joan RENDU

*Senior Engineer, Flight Control Systems
Customer Services*

1 | Introduction

In 1998, two A340 operators reported that when performing a rudder travel check, pedal displacement was found to be rough. Investigation evidenced that pens were stuck in the rudder pedal mechanism. These objects had fallen down from the cockpit through the cutouts of the cockpit pedals assembly covers. This led Airbus to develop a device to prevent such occurrences on the A330/340 and A320 family of aircraft.

In view of the remaining number of aircraft flying without this modification, it seems worthwhile to remind operators about the existing modifications.

2 | Original rudder pedal protective cover

The original cockpit pedals assembly covers presented a 5 cm open gap, to allow free movement of the rod connecting the pedal to the brake mechanism.

This unprotected gap let objects like pens or calculators slip into the braking mechanism.



*Protective cover
with no brush*

3 | Modified rudder pedal cover

The first events were reported on A340 aircraft and new pedal covers with brush were developed for the A330/340 family. Due to similarity in design, a similar cover was introduced on the A320 family as well.



Detail of brush

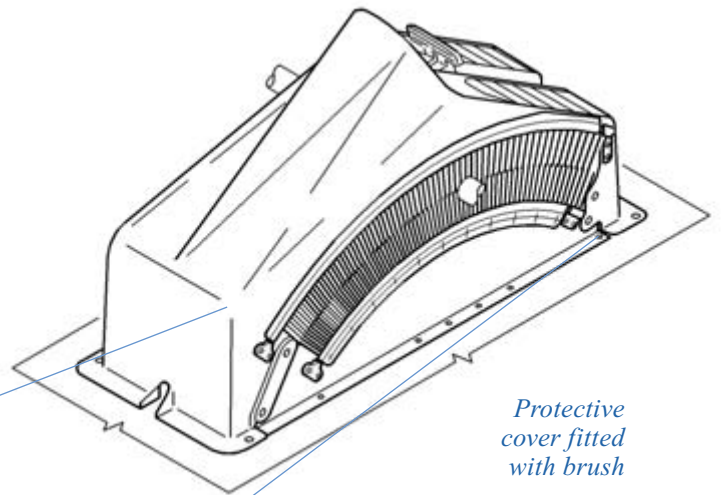

Protective cover fitted with brush

4 | New case reported

Recently one operator reported an event on an A320 aircraft.

The report indicates that, during preflight, the rudder pedal felt jammed. Investigations showed this was again due to a foreign object located into the pedal mechanism. The aircraft was pre-mod and the service bulletin was not embodied.

5 | Conclusion

Following this latest event and in order to prevent objects from falling into the pedal mechanism, Airbus would like to promote the following modifications:

A330

Modification n° 47292 fitted in production on aircraft models A330-200 from MSN 0339 and on models -300 from MSN 0342

Service bulletin n° 27-3074

A340

Modification n° 47292 fitted in production from MSN 0335

Service bulletin n° 27-4080

A318

Fitted on all aircraft

A319/320/321

Modification n° 28555 fitted in production from MSN 1344/1334/1356 respectively

Service bulletin n° 27-1131

The title of SB 27-1131, which is currently "Rudder mechanical control introduce modified rudder pedal mechanism assembly" will be changed to a more precise title "Introduce a means to prevent foreign object falling in rudder pedal mechanism assembly", and an OIT will be issued to inform operators.



Why do certain AMM tasks require equipment resets?



By: Duncan HARRIS

*Flight Guidance and
Navigation Systems Engineer
Customer Services*



1 | Introduction

While Line Replaceable Unit (LRU) replacement is often performed under significant pressure to maintain a timely aircraft departure, the relevant Aircraft Maintenance Manual (AMM) should not be forgotten. This article looks at one aspect of those AMM procedures whose importance may not always be entirely understood.

While the AMM may not always explicitly require a reset, this can be accomplished by an OFF/ON action request. For example, when starting a task, it may simply require switching OFF certain LRUs. This is accomplished either by pulling the relevant Circuit Breaker or by Cockpit Push Button. At the end of the task, when returning the aircraft to original configuration, the operator is required to switch the LRU back ON. A reset is effectively performed by the OFF/ON action. The LRU may also be switched OFF to avoid electrical or data disturbances in the affected system.

2 | Why do certain AMM tasks require equipment resets?

The reset is often necessary to clear faults recorded by systems before or even possibly during maintenance. Some systems (the example below illustrates this) use fault latching mechanisms. That is to say that once a fault has been detected, the input system will be considered unavailable until the user system is next reset.

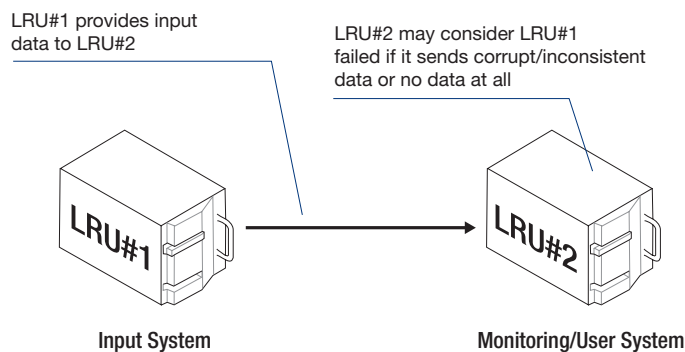

Typically if maintenance actions are performed to correct a given fault, it can be necessary to reset user systems to ensure that they consider the input system operational again.

3 | An example of Air Data/Inertial Reference Unit (ADIRU) replacement

Airbus recently investigated an event in which it was found that an aircraft departed in Alternate Flight control law following maintenance actions not performed fully according to AMM procedure. The circumstances of this event were as follows: During flight an ADR#1 (Air Data Reference) fault was detected. The ELAC (Elevator and Aileron Computer) on detecting this fault, latched the ADR#1 as failed until its next reset. The ELAC subsequently used only ADR#2 and #3 data for calculations.

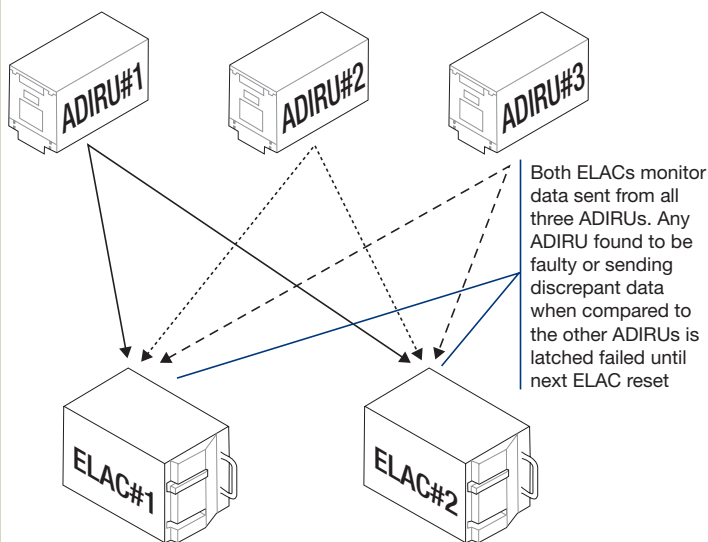

Upon landing, the maintenance crew swapped ADIRU#1 and #3, consequently the faulty ADIRU#1 became ADIRU#3. ADIRU#3 was therefore placed INOP as per MEL and the aircraft dispatched. At no point was an ELAC & SEC reset or aircraft electrical power reset performed. The consequence of this was significant: the ELAC kept its memory of ADR#1 Fault latched from the

previous flight. In addition it detected that the ADR#3 was INOP. Without ADR#1 or #3, only ADR#2 was considered available. Under these conditions the Electronic Flight Control system is only capable of operating in Alternate Law.

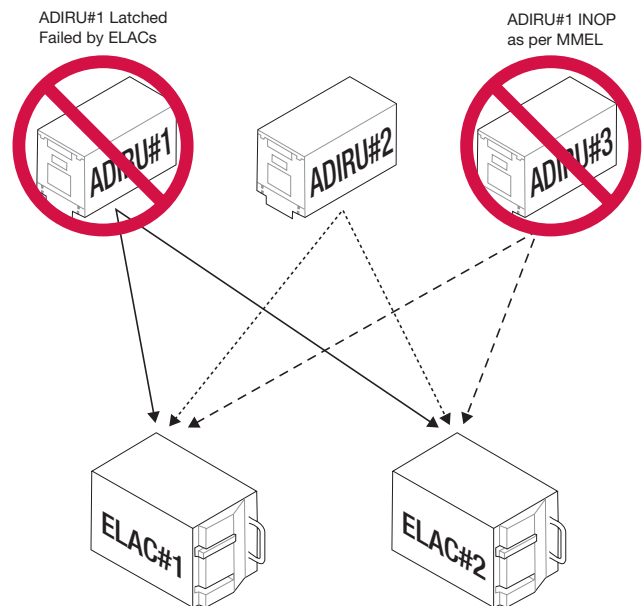

Had the maintenance crew correctly followed the AMM, including the ELAC reset, then the ADR#1 fault latched by the ELAC would have been reset and the Alternate law condition avoided.

5 | Conclusion

- Remember to always follow the relevant AMM task, even if each step may not always appear necessary.
- If in any doubt:
 - Contact Airbus customer support to task for assistance.
 - Perform an electrical reset of the aircraft: cut all aircraft electrical power, wait 5 minutes, and then power up again.



Slide/Raft Improvement



By: Fabien SAUVAGE
Emergency Equipment Engineer
Customer Services

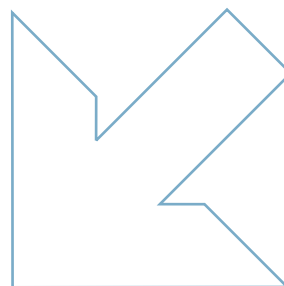

1 | Introduction

For years Airbus has been encouraging operators to report all escape slide and slide raft deployments, whether scheduled or inadvertent, successful or unsuccessful, in order to improve their reliability.

The number of reportings, however, has steadily decreased and represents only a fraction of the estimated number of deployments. The purpose of this article is to draw attention to the need for regular and extensive feed back of slide deployment information to Airbus.

2 | Regulatory requirements

Every 36 months, operators have to perform a certain number of slide deployments, which is a function of the number of doors on the considered type of aircraft, irrespective of the fleet size.

A330/A340 fleets can be combined for common doors, therefore an operator equipped with a mix of A330/A340 will have to deploy 4 slides, as this type of aircraft is equipped with 4 doors per side (5 on the A340-600).

These deployment may be performed on either side and do not all have to be performed on the same aircraft. Inadvertant deployments may not be used to satisfy these requirements.



3 | Product improvement

Based on the above requirements, Airbus has estimated that on the A330/A340 family alone, approximately 140 deployments should have been performed in 2007. Only 14, however, have been reported to Airbus, of which 7 were successful.

Slide reliability is increasing every year because of the continuous system and component improvements and thanks to the input from our customer airlines. Exhaustive deployment reporting is key to a better overview of the slide and slide raft reliability, and allows to identify areas that could be improved. Close monitoring and reporting of in-service occurrences is essential for an efficient event analysis and associated engineering investigation/resolution launch.

4 | Recommendations

The Aircraft Maintenance Manual and SIL 25-124 specify how deployment tests should be performed. The last page of SIL 25-061 Rev 3 includes a slide/raft deployment reporting form to be forwarded to Airbus Customer Services.

5 | Conclusion

In order to be able to improve the slide/rafts reliability, and hence passenger safety, we do encourage the reporting of all deployments, whether successful or unsuccessful, scheduled or inadvertent.



Cabin attendant falling through the avionics bay access panel in cockpit



By: Per-Oliver GUENZEL
Flight Safety Advisor
 A330/A340 program



1 | Introduction

Airbus has received reports of cabin attendants falling through the avionics hatch door located in the cockpit, when it is open for maintenance purposes. In most of the cases the cabin attendant hurt him/herself only slightly and could continue his/her duty. But there were also some occurrences where the cabin attendant couldn't continue his/her duty.

In 2001, an OIT (ref.: AI/SE 999.0002/01) was published to inform operators about such events and to provide some general recommendations. In addition, Airbus has developed a device that should contribute to prevent such mishaps.



Figure 1: Open access hatch seen from cockpit door (prototype of protective arm shown)

2 | Avionics bay access hatch

The avionics compartment access hatch is located in the cockpit behind the captain's seat. It opens upwards from front to back. When the hatch is open, it rests vertically and covers approximately 80% of the corridor width. This makes the hatch position noticeable and requires care to be taken to move around it when entering the cockpit. Therefore anyone entering the cockpit while the hatch is open should notice it (see fig. 1 and 2).



Figure 2: Open access hatch seen from behind the first officer's seat

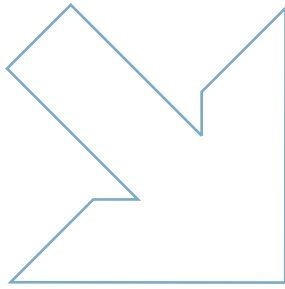

The reports received by Airbus about a cabin attendant falling into the hatch are not very detailed, but usually the cabin attendant entered the cockpit to provide some beverage to the flight crew, he/she stepped in the open hatch not realizing that there was a “hole” or fell in when stepping backwards to leave the cockpit.

Airbus decided to develop a protective device to help airlines prevent such events.

3 | Avionics bay access hatch protective arm

Mechanics need to have easy access to the avionics bay from the cockpit, sometimes with electronics equipment, thus it was necessary to develop a “protection” that doesn’t interfere with the mechanics work area. This “protection” had to be easily retrofittable, act as a visual attention getter to warn those who don’t realize the “hole” in front of them and provide enough physical resistance to somebody stepping back against it. However, its intent is not to act as a solid barrier to prevent somebody from falling.

The best compromise found by Airbus engineers is a protective arm that is attached to the hatch and unfolded when the hatch is open (see fig 3 & 4).



Figure 3: Avionics access hatch with folded protective arm



Figure 4: Avionics access hatch with unfolded protective arm

The following SBs are available to retrofit an avionics compartment access hatch with a protective arm on the different aircraft series.

A330-200/-300: SB 25-3356

A340-200/-300: SB 25-4292

A340-500/-600: SB 25-5146

The estimated installation time of the SB is 3 hours.

The same modification is available as an option for production a/c.

Safety **First**

Subscription form



SAFETY FIRST - The Airbus Safety Magazine

Subscription Form

To be sent back to

AIRBUS FLIGHT SAFETY OFFICE

Fax: 33 (0)5 61 93 44 29

Mail to: marie-josee.escoubas@airbus.com

Name

Surname

Job title/Function

Company/Organization

Address

.....

.....

Post/Zip Code

Country

Telephone

Cell phone

Fax

E-mail

Please send me the digital copy*

Please send me the paper copy* *(Please note that paper copies will only be forward to professional adresses)*

* Please tick the appropriate case



AIRBUS

AN EADS COMPANY