

The Airbus safety magazine

#33

# Safety first



**AIRBUS**

**Safety first, #33** January, 2022. Safety first is published by Airbus S.A.S. - 1, rond point Maurice Bellonte - 31707 Blagnac Cedex/France. Editor: Yannick Malinge, Chief Product Safety Officer. Concept Design by Airbus MultiMedia Studio 20211023. Reference: X00D16031905. Photos by Airbus, S. Ramadier, H. GOUSSÉ.

This brochure is printed on Symbol Tatami White. This paper is produced in factories that are accredited EMAS and certified ISO 9001-14001, PEFC and FSC CoC. It is produced using pulp that has been whitened without either chlorine or acid. The paper is entirely recyclable and is produced from trees grown in sustainable forest resources. The printing inks use organic pigments or minerals. There is no use of basic dyes or dangerous metals from the cadmium, lead, mercury or hexavalent chromium group. The printer, Art & Caractère (France 81500), is engaged in a waste management and recycling programme for all resulting by-products.

## Editorial Team

Guillaume Estragnat   Vanessa Sadi   Gwyneth Duggan   Tim Roach



© Airbus S.A.S. 2022 – All rights reserved. Proprietary documents.

By taking delivery of this Brochure (hereafter "Brochure"), you accept on behalf of your company to comply with the following guidelines:

» No other intellectual property rights are granted by the delivery of this Brochure than the right to read it, for the sole purpose of information.

» This Brochure and its content shall not be modified and its illustrations and photos shall not be reproduced without prior written consent of Airbus.

» This Brochure and the materials it contains shall not, in whole or in part, be sold, rented, or licensed to any third party subject to payment.

This Brochure contains sensitive information that is correct at the time of going to press.

This information involves a number of factors that could change over time, affecting the true public representation. Airbus assumes no obligation to update any information contained in this document or with respect to the information described herein.

Airbus S.A.S. shall assume no liability for any damage in connection with the use of this Brochure and of the materials it contains, even if Airbus S.A.S. has been advised of the likelihood of such damages.

# Safety first

**The Airbus magazine contributing to the enhancement of the safety of aircraft operations by increasing knowledge and communication on safety related topics.**

Safety first is published by the Product Safety department. It is a source of specialist safety information for the use of airlines who fly and maintain Airbus aircraft. It is also distributed to other selected organizations and is available on digital devices.

Material for publication is obtained from multiple sources and includes selected information from the Airbus Flight Safety Confidential Reporting System, incident and accident investigation reports, system tests and flight tests. Material is also obtained from sources within the airline industry, studies and reports from government agencies and other aviation sources.

All articles in Safety first are presented for information only and are not intended to replace ICAO guidelines, standards or recommended practices, operator-mandated requirements or technical orders. The contents do not supersede any requirements mandated by the State of Registry of the Operator's aircraft or supersede or amend any Airbus type-specific AFM, AMM, FCOM, MMEL documentation or any other approved documentation.

Articles may be reprinted without permission, except where copyright source is indicated, but with acknowledgement to Airbus. Where Airbus is not the author, the contents of the article do not necessarily reflect the views of Airbus, neither do they indicate Company policy.

Contributions, comment and feedback are welcome. Enquiries related to this publication should be addressed to:

**Airbus**  
**Product Safety department (W)**  
1, rond point Maurice Bellonte  
31707 Blagnac Cedex - France  
[safetycommunication@airbus.com](mailto:safetycommunication@airbus.com)

Visit us at [safetyfirst.airbus.com](https://safetyfirst.airbus.com)  
or install the Safety first app:



# editorial



**YANNICK MALINGE**

SVP & Chief  
Product Safety Officer

---

Dear Aviation colleagues,

Looking back at 2021, and even 2020, the industry has undoubtedly faced its share of turbulence from the health and financial challenges associated with the ongoing Covid-19 crisis. The industry as a whole has certainly been tested, and it was a huge test. However, we can now observe some positive signs of recovery, even if the world is not yet free of this crisis.

On the safety front, I am sure that everyone will agree that we have all been able to navigate through this crisis thanks to our collective resilience, which relies on our shared safety values. Reinforcing this resilience has remained a focus for all of us, from OEMs, suppliers, operators, authorities and aviation organisations. We need to maintain this focus to help address the challenges that lay ahead of us. Challenges such as getting out of the Covid-19 tunnel, managing our journey toward greater sustainability, and continuing to enhance our safety record.

A word on Airbus Safety first to say we are pleased to see more than 1,300 daily readers of articles on [safetyfirst.airbus.com](https://safetyfirst.airbus.com) and the Safety first app in 2021, and this continues to grow. Let's keep sharing our lessons learned and safety experiences, and keep up the connection with all of our aviation colleagues by sharing these articles.

The entire Airbus Safety team and I pass on our best wishes for open and clear skies ahead in 2022.

A handwritten signature in black ink, appearing to read 'Y. Malinge', with a horizontal line underneath.

# Safety first

The Airbus Safety magazine

Also available in app  
and website versions



Visit us at [safetyfirst.airbus.com](https://safetyfirst.airbus.com)





## **The 26th Airbus Flight Safety Conference will be held in Dubai, 28-31 March 2022**

**This event provides the opportunity for Airbus and its customers to exchange on how we can further strengthen safety in our Air Transport System.**

With the objective of strengthening safety for what's next, we will address how we have captured the lessons learned from the Covid-19 crisis across our industry, including a focus on maintenance, flight operations and training activities.

We will also present initiatives for securing safety enhancements on the Airbus fleet with the Safety Beyond Standard Programme. Finally, we will look ahead to the foreseeable evolution of technology in the cockpit, aircraft functions and flight operations.









# Safety first #33



 Flight Operations

 Cabin Operations

 Ground Operations

 Maintenance

## OPERATIONS

P06 

Safe Handling of TCAS Alerts

## TRAINING

P18 

Training Pilots for Resilience

## OPERATIONS

P28 

Lining Up with the Correct Glide Slope

P40   

Landing with Nosewheels at 90 degrees



# Safe Handling of TCAS Alerts

TCAS RAs are not correctly followed in more than 40% of cases according to a recent study published by Eurocontrol, making non-compliance with TCAS RAs one of the top 5 Air Traffic Management (ATM) operational and safety risks.

This article explains how the TCAS Alert Prevention (TCAP) and AP/FD TCAS functions can improve the situation by respectively reducing the number of RAs in congested airspace, and assisting flight crews to follow TCAS RAs in an optimum manner. The article also recalls the TCAS warning procedure step-by-step, with and without the AP/FD TCAS function and provides guidance for training flight crews.

This article is also available on [safetyfirst.airbus.com](https://safetyfirst.airbus.com) and on the Safety first app for iOS and Android devices.





# TCAS ALERTS IN OPERATIONS

Flight crews reacted correctly to a TCAS Resolution Advisory (RA) in only 58.7% of cases according to a recent study published by Eurocontrol(\*) in April 2021. In 29.8% of cases, the flight crew reacted by modifying the aircraft trajectory but did not reach the expected target. In 11.5% of cases, the flight crew did not react, or they reacted excessively and sometimes had the opposite reaction to what the RA requested.

Flight crews must always remember that a prompt and accurate response to TCAS RAs is important to maintain the highest level of safety.

The Eurocontrol study observed a **low level of compliance with “Climb” or “Descend” RAs**: only 33.7% of the “climb” and “descend” RAs were correctly followed, 44.2% did not reach the expected target, and 22.1% were not flown correctly.

“Only a third of the ‘climb’ and ‘descend’ RAs were correctly followed”

\* “The assessment of pilot compliance with TCAS RAs, TCAS mode selection, and serviceability using ATC radar data” issue 2.1 published on 09-APR-2021 by Eurocontrol.

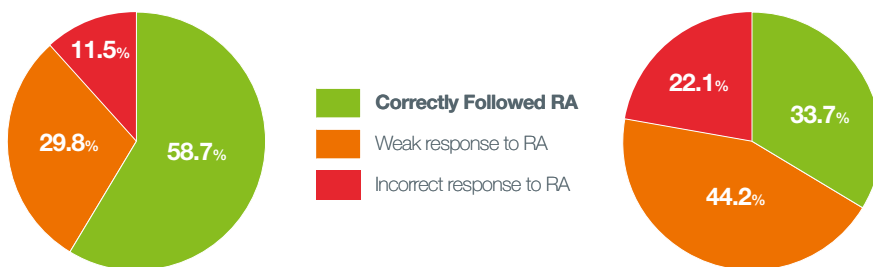

All Resolution Advisories

“Climb” and “Descend” RAs only

(fig-1)

Flight crew response to TCAS RAs (data from the Eurocontrol study\*)

## Why “level off” RAs are triggered in congested airspace?

The TCAS warning logic uses the current trajectory of the aircraft to predict collision threats. This does not anticipate the expected level off when the aircraft finishes its climb or descent and reaches its expected flight level. If another aircraft approaches on an adjacent flight level, it can trigger a “level off” RA, or a “level off” with a corresponding “climb” or “descend” RA (fig.2). This is more likely to occur in congested airspace.

(fig.2)

Example of an RA triggered when reaching a cleared flight level, near an aircraft flying on an adjacent flight level

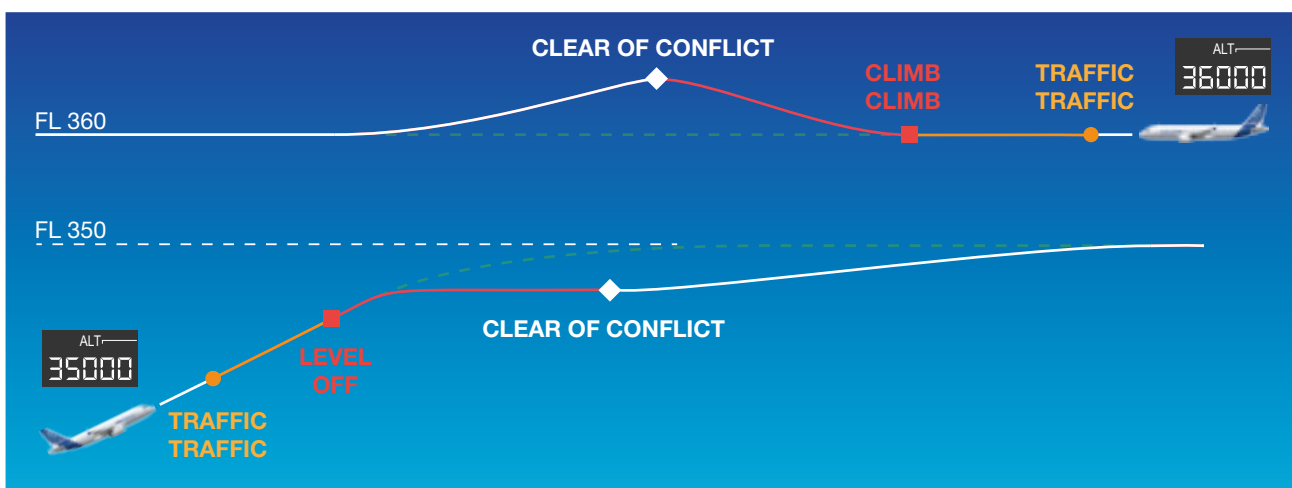

“‘Level off’ RAs made up 65% of all observed RAs in the Eurocontrol Study.”

“Level off” RAs made up 65% of all observed RAs in the Eurocontrol Study. ICAO recommends that the flight crew manually select a lower vertical speed when approaching the target flight level to prevent the triggering of “level off” RAs. This solution is effective but not always optimal, because it requires intervention by the flight crew. This is why Airbus developed the **TCAS Alert Prevention (TCAP) function**.

## TCAP PREVENTS RAs

The TCAP function is an improved **ALT\*** altitude capture law for flight guidance computers. When a TCAS Traffic Advisory (TA) is triggered for an aircraft that is almost at its target flight level, the **ALT\*** guidance mode will engage earlier and use a reduced vertical speed to reach the target altitude. This will prevent the need for an RA (fig.3). If the **ALT\*** guidance mode is already engaged when the TA is triggered, the TCAP function will further reduce the **ALT\*** vertical speed to prevent the RA.

If an Operator has a mixed fleet configuration of aircraft with and without the TCAP function activated, the flight crew can still manually select a lower vertical speed when approaching the target flight level on any aircraft depending on the Operator’s policy.

**(fig.3)**  
Principle of the TCAP function

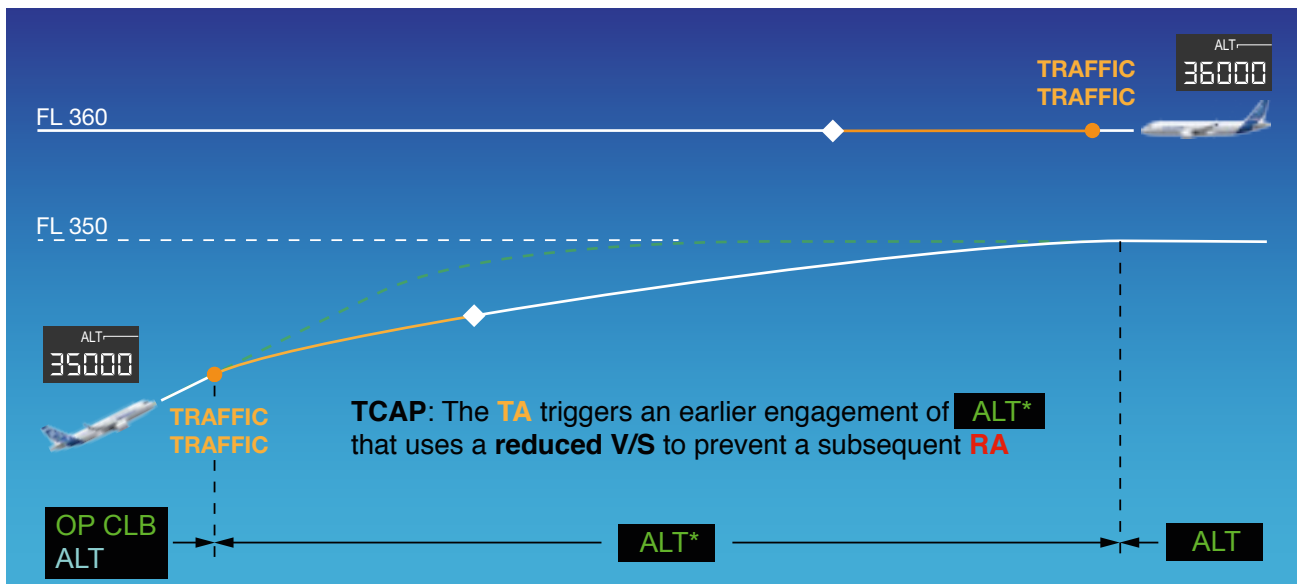

## TCAP Availability

The TCAP function is installed on A350 aircraft and on A380 aircraft delivered since July 2013. TCAP is also installed on all A320 family aircraft produced since early 2021, and on all A330 aircraft produced since October 2017 (since February 2016 on A330 aircraft with RR engines).

A380 aircraft delivered before July 2013 can be retrofitted using the activation Service Bulletin (SB) A380-22-8011.

Operators can retrofit TCAP on older A320 family and A330 aircraft. These aircraft must be fitted with a minimum standard of TCAS and a minimum standard of FMG(E)C. The minimum TCAS computer standard must be:

- ACSS **TCAS 2000** Change 7.0, or
- ACSS **T2CAS Std 1**, or
- ACSS **T3CAS Std 1**, or
- Collins **TCAS TTR920** Change 7.0, or
- Honeywell **TCAS TPA81A** Change 7.0

On **A320 family aircraft**, the TCAP function is automatically activated on aircraft equipped with the following:

- An FMGC with flight guidance Standard **PI17, PC20** or a subsequent standard
- Wiring installed by Mod 38790 (+Mod 30248 if T2CAS) between the FMGC and the TCAS/T2CAS/T3CAS computer.

On **A330 aircraft**, an activation service bulletin is necessary in addition to installing an FMGEC with flight guidance standard **HJ2** or **H3**.

## AP/FD TCAS ENSURES AN OPTIMUM HANDLING OF THE TCAS RAs

Sometimes the flight crew does not comply with RAs as expected or performs a maneuver that is too weak or excessive (**fig.4**). To help the flight crew perform optimum maneuvers in accordance with the RA, Airbus developed the AP/FD TCAS function. AP/FD TCAS enables the flight crew to follow TCAS function.

**(fig.4)**  
Response to TCAS RAs are not always optimum

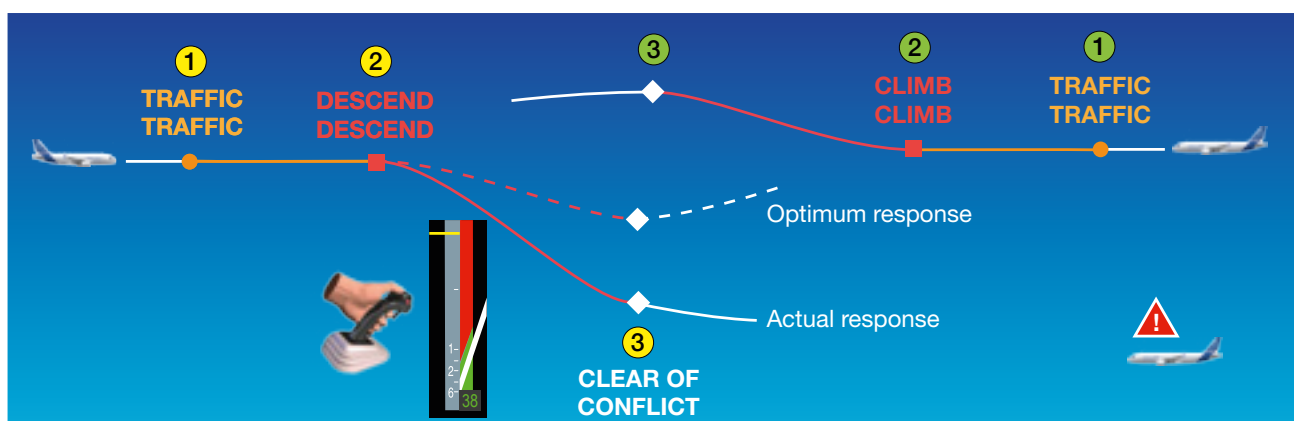

## AP/FD TCAS enables the flight crew to follow TCAS RAs with AP ON or FD guidance

The AP/FD TCAS function is an additional flight guidance mode of the autoflight system available for A320, A330, A350 and A380 aircraft. This function enables flight crews to either keep the autopilot ON to automatically follow the RA, or to manually perform the RA maneuver using FD guidance (fig.5): **1** When a TA is triggered, the **TCAS** mode is armed. **2** When an RA is triggered, the **TCAS** mode is engaged and targets a vertical speed **200 ft/min inside the RA green band**. **3** When the aircraft is clear of conflict, the TCAS mode then reverts to a **V/S +/- 1000** vertical speed mode toward the initially selected altitude.

**(fig.5)**

AP/FD TCAS ensures optimum handling of the TCAS RAs

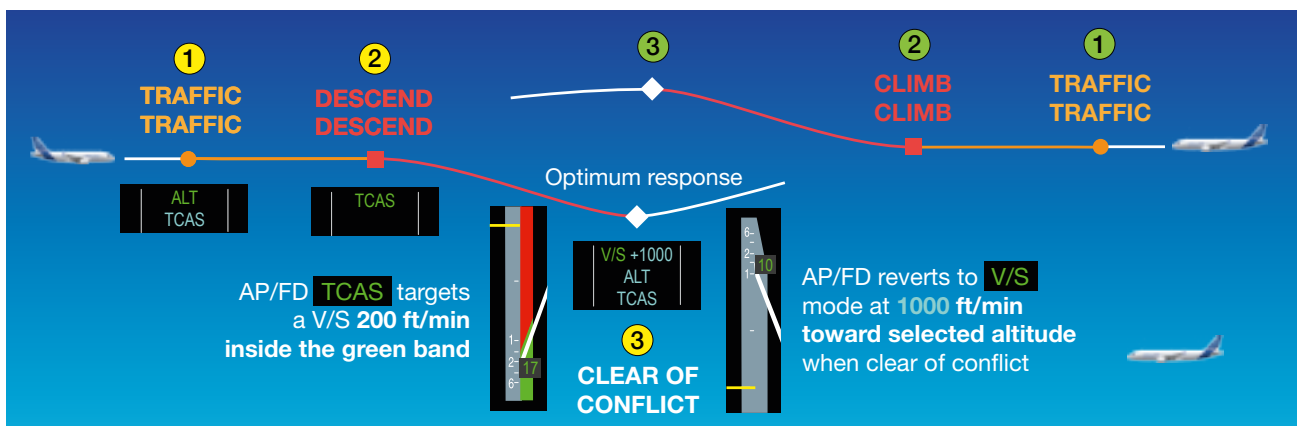

“If the flight crew prefers to follow the RA using the standard TCAS warning procedure, they can revert to it at any time.”

The AP/FD TCAS function assists flight crews to:

- Correctly respond to the RA and in a timely manner.
- Perform a maneuver only to the extent necessary.
- Perform a maneuver with a moderate load factor to ensure passenger comfort and to reduce the risk of injury.
- Prevent the triggering of TCAS alerts on other aircraft.

### Possible reversion to the standard procedure

If the flight crew prefers to follow the RA using the standard TCAS warning procedure, they can revert to it at any time. However, an Airbus analysis of more than 130 000 flights performed by A350 and A380 aircraft confirms the confidence of flight crews in the AP/FD TCAS function: in 91% of the RA situations, the flight crew kept the autopilot ON.

## AP/FD TCAS Availability

AP/FD TCAS is installed on all A350 and A380 aircraft. The function is installed by default on all A320 family aircraft produced since February 2017, and on all A330 aircraft produced since April 2012.

The AP/FD TCAS can be installed on A320 family and A330 aircraft that comply with the minimum system prerequisites listed below:

### Minimum system prerequisites for A320 family aircraft

<b>FMGC</b> H2C13 or S6C13 or H2BPC13 or S7PC13 for aircraft fitted with CFM engines	MOD 152224 or MOD 152225 or MOD 154191 or MOD 155031
<b>FMGC</b> H2I12 or S6I12 or H2BPI12 or S7PI12 for aircraft fitted with IAE/PW engines	MOD 152967 or MOD 152968 or MOD 154192 or MOD 155032
<b>FWC</b> H2F5	MOD 37871
<b>EIS:</b> EIS2 S8-2 or EIS1 V70	MOD 38146 or MOD 150603
<b>TCAS</b> change 7 or T2CAS or T3CAS	MOD 27740 or 27698 or 36559 or 34637 or 39146
<b>FDIMU</b> with new FDIU Standard S15	MOD 150037 or MOD 150038
<b>FCU</b> standard 4	MOD 38132
<b>Wiring provisions</b>	MOD 38790

### Minimum system prerequisites for A330 aircraft

<b>FMGEC</b> P4H3 or P5H3 or P5H3 or T5AH3	MOD 205773 or MOD 204758 or MOD 207492 or MOD 204775
<b>FWC</b> T3	MOD 58751
<b>EIS:</b> EIS2 L7 or EIS1 V513	MOD 57115 or MOD 201332
<b>TCAS</b> Change 7.0 or T2CAS or T3CAS	MOD 47392 or 52992 or 58449 or 46986 or 47572 or MOD 46728
<b>FDIMU</b> Standard L10 (Only if in EIS1 V513 configuration. Not necessary for EIS1 V514)	MOD 58688
<b>FCU</b> Standard 3	MOD 200272
<b>Wiring provisions</b>	MOD 57112 and MOD 56759 and (MOD 200939 (for TCAS) or MOD 201160 (for T2CAS or T3CAS))



**(fig.6)**

AP/FD TCAS installation status for A320 family and A330 aircraft

## Many in-service aircraft have all prerequisites for activation of AP/FD TCAS

An analysis of the in-service fleet shows that only slightly more than 30% of A320 family and A330 aircraft have the AP/FD TCAS function activated. The analysis also shows that a number of A320 family and A330 aircraft have all the system prerequisites installed and only need to activate the function to be able to use it. Operators should contact their Airbus Customer Support Director for information on the service bulletin about activating the AP/FD TCAS function on A320 family and A330 aircraft.

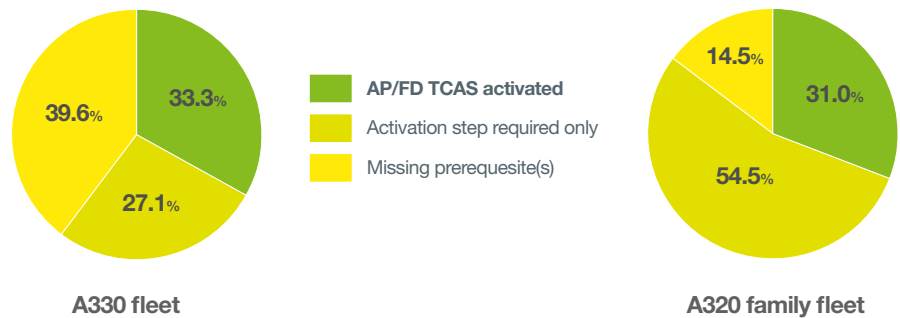

“When operating a mixed fleet, flight crews can easily check the Aircraft Configuration Summary (ACS) table in the QRH during cockpit preparation.”

## AP/FD TCAS: Mixed Fleet is not an Issue

Despite the possibility of retrofitting the AP/FD TCAS function on in-service A320 and A330 aircraft, some Operators may not be able to equip a full fleet with AP/FD TCAS. This should not stop Operators from activating the function on their capable aircraft, because operations with a mixed fleet are possible.

When operating a mixed fleet, flight crews can easily check the **Aircraft Configuration Summary (ACS)** table in the QRH during cockpit preparation. This will tell them if the aircraft has the AP/FD TCAS function activated.

In addition, flight crews must know how to apply both TCAS warning procedures (with and without AP/FD TCAS function), because even with the AP/FD TCAS activated, they will need to apply the standard TCAS warning procedure if the AP/FD TCAS function is inoperative.

Both procedures are described in the FCOM and QRH Memory Items part [MEM] SURV / TCAS WARNING.

### Step 1: If a TA is triggered, select the appropriate procedure to apply

- If **TCAS** is **NOT displayed** on the FMA, it is **not available or not installed**. If an RA is triggered, the PF announces “**TCAS, I have control**” and must be prepared to apply the standard TCAS warning procedure.
- If **TCAS** is **displayed** as armed on the FMA, the flight crew can use the AP/FD TCAS function in automatic or manual flight. In this case, the PF announces “**TCAS blue**”, ensures that the autothrust is engaged, and prepares to either fly the potential RA maneuver using autopilot or manually fly the RA with FD guidance.

### Step 1: "TRAFFIC TRAFFIC"

If AP/FD TCAS is NOT available

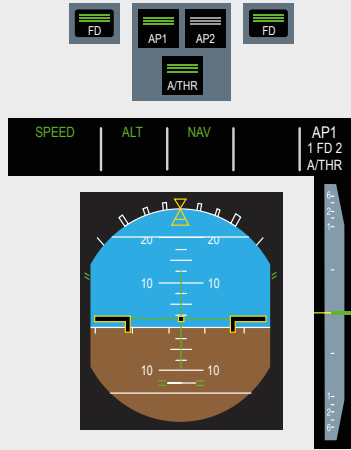

PF calls "TCAS, I have control"

If AP/FD TCAS is available

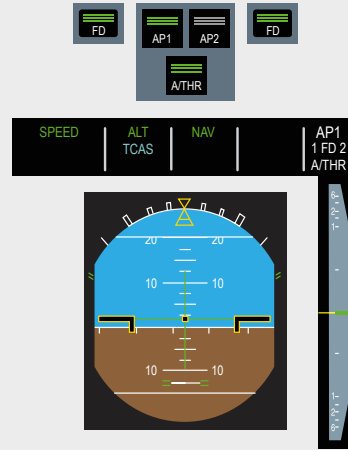

PF calls "TCAS blue"

### Step 2: Use the appropriate level of automation to follow the RA

Depending on the availability of the **TCAS** mode, the PF follows the RA with the appropriate level of automation:

- If the **TCAS** mode is not available or does not engage when the RA is triggered, the PF disconnects both the AP and the FD and flies the green on the V/S scale as per the standard TCAS warning procedure.
- If the **TCAS** mode engages when the RA is triggered, the PF can either leave the AP ON and monitor that the V/S reaches the green zone on the PFD, or manually follow the RA using FD guidance. The FD bars will automatically appear when the TCAS mode engages if they were previously switched off.

### Step 2: "CLIMB CLIMB"

If AP/FD TCAS is NOT available

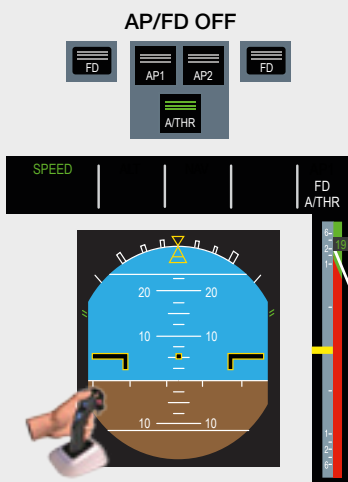

PF flies the green

If AP/FD TCAS is available

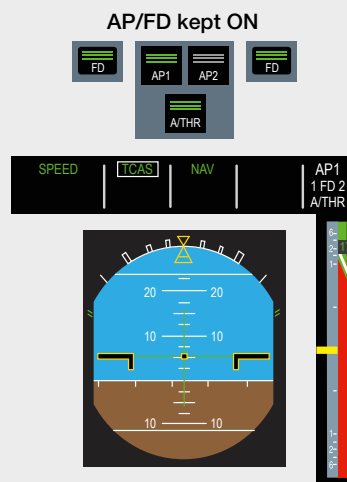

PF calls "TCAS" & monitors V/S inside the green

AP OFF

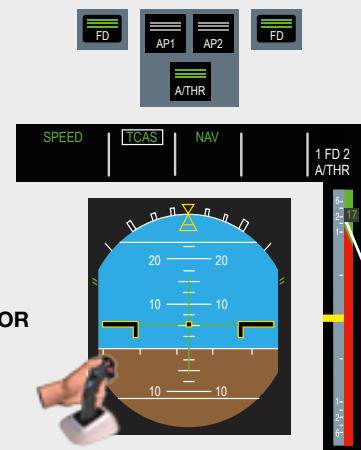

PF calls "TCAS" & follows FD to fly the green

### Step 3: Return to the initial trajectory when clear of conflict

When the aircraft is clear of conflict:

- If the RA was flown manually, the PF may adjust both the lateral and vertical trajectory to resume normal navigation in accordance with ATC instructions and may re-engage the AP and FD.
- If the RA was flown in **TCAS** mode, the flight guidance reverts to **V/S +/- 1000** mode when clear of conflict to go back to the selected altitude. The PF should then engage an appropriate vertical mode, or adjust the V/S target, in accordance with ATC instructions.

### Step 3: "CLEAR OF CONFLICT"

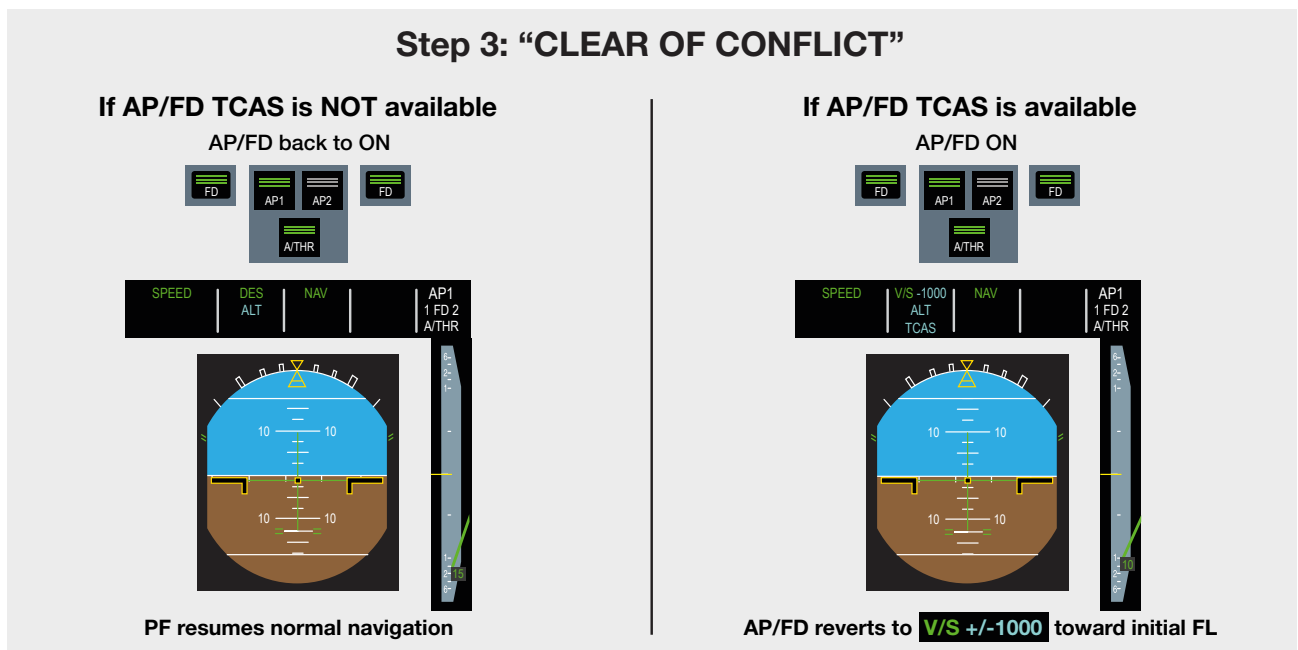

#### Video

"Operational use of the TCAS"



#### Article

Airbus AP/FD TCAS mode: a new step towards safety Improvement



## INFORMATION

The "**Operational use of the TCAS**" video available on the Worldwide Instructor News (WIN) website provides detailed information about the TCAS and how to use it. The video also describes the AP/FD TCAS function and provides answers to frequently asked questions.

The "Getting to Grips with Surveillance" brochure issue 2 also provides information about the TCAS and is available for download on the AirbusWorld portal.

Refer also to our first Safety first article on AP/FD TCAS published in February 2009: "**Airbus AP/FD TCAS mode: a new step towards safety Improvement**".

### Training on TCAS Warning Procedures

The Airbus Flight Crew Training Standards (FCTS) manuals provide recommendations for both type rating and recurrent training programs on how to train flight crews to apply the TCAS procedures. The manuals contain recommendations to define the training objectives in line with ICAO (doc 9995 Manual of Evidence-Based Training) and IATA recommendations (Evidence-Based Training Implementation Guide). FCTS manuals are available for download from the AirbusWorld portal.

During the type rating and recurrent training courses, flight crews should be trained on how to apply the TCAS procedure both with and without the AP/FD TCAS function. This is to ensure that the flight crew will react correctly to a TCAS warning if the AP/FD TCAS function is not available or if it is inoperative on their aircraft.

Evidence-Based Training (EBT) programs recommend that the TCAS procedure training should be performed at least one time every three years. ■

“Flight crews should be trained on how to apply the TCAS procedure both with and without the AP/FD TCAS function.”



## INFORMATION

### Upcoming modification (May 2022) of the TCAS Warning procedure in approach:

The TCAS WARNING procedure will be updated in May 2022 to standardize the procedure on all Airbus aircraft (all aircraft types, with or without AP/FD TCAS) and to comply with EASA and FAA regulation requirements. The procedure will be amended as follows:

- **If any “CLIMB” audio indicator sounds during the final approach:**  
GO AROUND.....PERFORM.

### CONTRIBUTORS:

#### **Christophe BAROUX**

Product Development  
Architect - Upgrade  
Services  
Customer Support

#### **Florence CARDONA**

Airframe Services  
Marketing

#### **Cédric CORRAL**

Flight Management  
& Auto Flight Systems  
Manager  
Design Office

#### **Xavier DUREPAIRE**

Training & Flight Ops  
Pilot Instructor  
Customer Support

#### **Maria Luisa LOPEZ VILLAREJO**

Product Safety  
Enhancement  
Product Safety

#### **Christine VILLENEUVE**

Product Development  
Architect - Upgrade  
Services  
Customer Support

It is crucial that flight crews respond promptly and accurately to TCAS Resolution Advisories (RAs) to maintain the highest levels of safety. However, TCAS RAs are not always followed as expected in operations according to a study published by Eurocontrol in April 2021. This confirms why non-compliance with TCAS RAs is identified as one of the current top-5 ATM operational risks.

The TCAP function can improve the situation by preventing RAs in congested airspace. The AP/FD TCAS function can provide assistance to the flight crew for following the TCAS RAs in an optimum way.

The TCAP and AP/FD TCAS functions are now activated on all newly built aircraft. Many A320 family and A330 in-service aircraft have all the system prerequisites and can easily activate the AP/FD TCAS function. Airbus encourages Operators to contact their Customer Support Directors for details on how to implement AP/FD TCAS on their aircraft and benefit from this function.

Flight crews can identify if an aircraft is equipped with the AP/FD TCAS function by checking the Aircraft Configuration Summary table in the QRH. In addition, the flight crew will know if the AP/FD TCAS function is available when the **TCAS** guidance mode is displayed as armed on the FMA in the case of a TA. Flying a mixed fleet of aircraft with or without the AP/FD TCAS function is therefore not an issue.

During type rating and recurrent training, flight crews should be trained on how to apply both TCAS warning procedures, with and without the AP/FD TCAS function, so that they can apply the standard TCAS procedure if the AP/FD TCAS function is not available.

Evidence-Based Training programs recommend training flight crews on how to apply the TCAS warning procedures at least one time every three years.







# Training Pilots for Resilience

Resilience training is not a new concept in aviation. It was introduced in mandatory Crew Resource Management (CRM) training for pilots a few years ago. Resilience is built on a pilot's confidence and competencies. But what if they did not fly for many weeks or months?

With many aircraft returning to service following the massive fleet grounding our industry has faced as a result of the COVID-19 crisis, it is a good time to highlight the importance of resilience training.

This article is also available on [safetyfirst.airbus.com](https://safetyfirst.airbus.com) and on the Safety first app for iOS and Android devices.



## THE NEED FOR RESILIENCE

When an A300 cargo aircraft was hit on the left wing by a surface-to-air missile, all three hydraulic systems were lost. The Captain who was Pilot Flying immediately realized that engine control was the only means to safely land the aircraft. This was done by applying symmetric thrust control to adjust the pitch and speed, and asymmetric thrust control to adjust the bank angle. He did this based on the memory of a similar event that occurred a few years before when the flight crew took the initiative to use differential thrust to manage the loss of all hydraulic systems. The landing gear was extended by gravity and the flight crew eventually managed to land the aircraft without causing any injuries. This was a clear demonstration of flight crew resilience in an extraordinary situation.

Events like these may be considered as extreme startle events that a majority of flight crews may never see in their flying careers. Some may believe that training for resilience is only useful for such rare situations. Resilience is in fact useful anytime an unexpected situation occurs. An unexpected situation is not necessarily an extreme case such as the A300 example above. Resilience training for flight crews will help them to overcome the startle effect and temporary loss of situational awareness, to react in a controlled manner, and to continue a safe flight.

### What is resilience?

The term resilience has become widely used in recent years, and not only in aviation. Resilience is used to qualify and evaluate human performance when faced with unexpected disruptions in operation. EASA has defined flight crew resilience as, “the ability of a flight crew member to recognize, absorb and adapt to disruptions”.

#### Two key elements: competence and confidence

This high-level definition of resilience has been refined into two key elements by the Pilot Training Task Force (PTTF) of IATA: “flight crew resilience can be substantiated by raising the level of competence and by achieving the appropriate level of confidence (trust)” **(fig.1)**. In other words, to build their resilience, the flight crew needs to develop their competencies and their confidence.

“To build their resilience, the flight crew needs to develop their competencies and their confidence.”

#### **(fig.1)**

The two pillars of Resilience:  
Competence and Confidence



**(fig.2)**

Chart showing how training to increase the level of flight crew resilience can support faster performance recovery following a “startle” event.

### One main cause: the startle effect

When a flight crew is exposed to unexpected disruptions, they may experience a physiological reaction, known as the startle effect. This involuntary and uncontrollable reaction may be accompanied by a momentary loss of situational awareness resulting in a temporary deterioration in performance. The goal of resilience training is to minimize this deterioration and to enable the flight crew to recover performance as quickly as possible (fig.2).

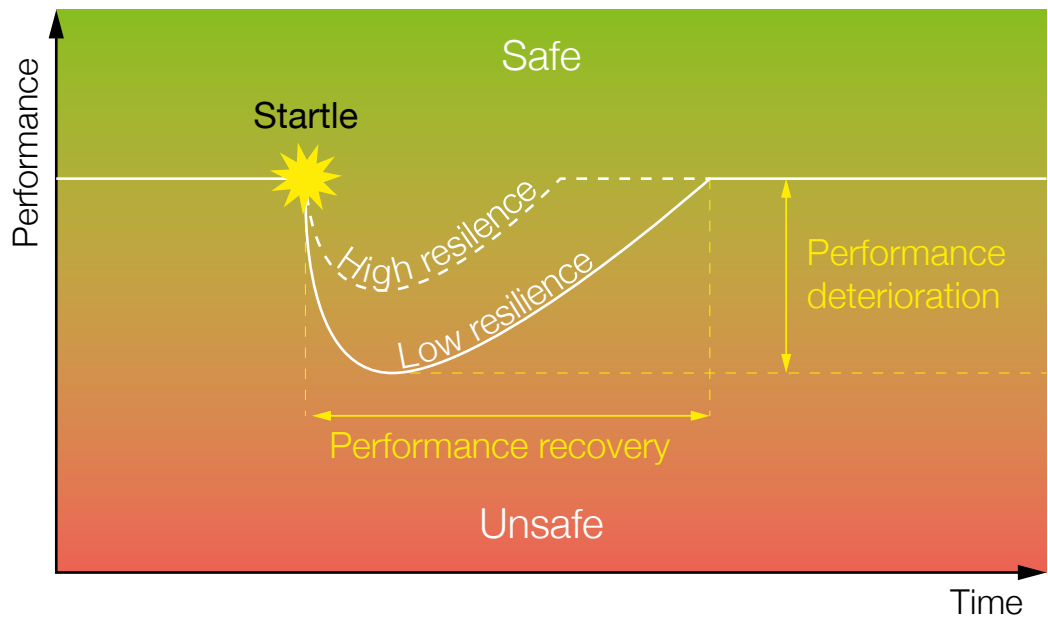

“When rigid routines are established, it will require more effort from the flight crew to adapt to an unexpected situation.”

### One main enemy: routine

Resilience is the ability to adapt to changing situations. Routine reduces this ability. Facing the same situations over again when training or during operations can create rigid patterns of actions. When rigid routines are established, it will require more effort from the flight crew to adapt to an unexpected situation.

### Unexpected but not always abnormal

The “disruptions” mentioned in the EASA definition of resilience do not refer only to an abnormal situation associated with a failure or a critical event. A disruption can be any deviation from the expected plan. For example, when the flight crew is suddenly cleared direct to the FAP even though they expected to follow the entire STAR as usual. This disruption in operations requires resilience to some extent and for the flight crew to quickly adapt to the unexpected situation.

### The importance of resilience

A flight crew will demonstrate resilience by the actions they perform to maintain sufficient safety margin following an unexpected or ‘startle’ event. How they apply their competencies to communicate, manage their workload, and make decisions, is illustrative of their level of resilience to these kinds of events and how they manage the threats and errors.

Resilience training for pilots throughout the process of pilot selection, education, training, and assessment has become an important element of flight safety. ■

# EVOLUTION OF TRAINING TOWARD MORE RESILIENCE

## Task-Based vs. Competency-Based Training

Flight crew training was traditionally a task-based approach, which evolved into a competency-based approach. This places priority on training and assessment of a finite number of competencies over the training of tasks alone. Airbus decided to move from task-based training and checking to a competency-based training and assessment program in 2014 with the introduction of the A350 Type Rating.

### Task-based training approach

Traditional approaches to training development involve separating jobs into tasks. For each task there is an assigned learning objective with associated elements in a training plan and checks to ensure that all of the learning objectives are met.

A limitation of this approach is that each task must be taught and assessed. In complex systems, or when jobs evolve rapidly, it may not be possible to teach and assess every task. Some examples of the tasks to be performed in the recurrent training and checking programs today are listed below:

- Takeoff with an engine failure
- Engine failure during the final approach segment
- Go around with one engine failed
- Landing with one engine failed
- Rejected takeoff
- 3D approach
- 2D approach
- System malfunctions in all ATA chapters
- Low visibility takeoff
- Low visibility approach
- Low visibility go around
- Low visibility landing

This task-based training approach is by nature only adapted to predictable scenarios. Flight crews have to apply this task-based approach, while developing their ability to also take into account the operational context.

### Competency-based training approach

ICAO defines competency as, “a dimension of human performance that is used to reliably predict successful performance on the job. A competency is manifested and observed through behaviours that mobilize the relevant knowledge, skills and attitudes to carry out activities or tasks under specified conditions.” In other words, the competency of an individual to proficiently perform on the job is demonstrated through observable behaviors. The observation of these behaviors, which relies on relevant **K**nowledge, the right set of **S**kills, and the appropriate **A**ttitude or motivation (KSA), can be used to predict future performance.

In Competency Based Training and Assessment (CBTA), the training goal is not to train the flight crew to react to every specific situation, but to be prepared for an infinite number of situations by developing a finite number of competencies. The training and assessment of a finite number of competencies is prioritized

“ In CBTA, the training goal is to be prepared for an infinite number of situations by developing a finite number of competencies. ”



over the training of tasks. This should enable pilots to successfully perform in a complex and changing operational environment. They should also be able to manage tasks and situations that are unforeseen, and for which they have not been specifically trained. This builds strong resilience.

For instance, EASA defines nine competencies (also used by Airbus) for flight crew training:

- Application of knowledge
- Application of procedures and compliance with regulations
- Communication
- Flight Path Management - Automation
- Flight Path Management - Manual control
- Leadership and Teamwork
- Problem Solving and Decision making
- Situation awareness and management of information
- Workload management

Observable behaviors are associated with each defined competency and are used for training and assessment purposes through a variety of scenarios. An assessment of competence is of course necessary in CBTA, but when completed, it provides the opportunity for pilots to learn most effectively when they are not under test conditions.

Task-Based Approach	Competency-Based Approach
<ul style="list-style-type: none"> <li>• Ever growing number of tasks to train</li> <li>• Train only for predicted situations</li> <li>• Isolated task training: difficulty to adapt</li> <li>• More time spent on checking</li> <li>• Generic training</li> <li>• Limited level of performance in complex and evolving environments</li> </ul> <p style="text-align: center;"><b>LOW RESILIENCE</b></p>	<ul style="list-style-type: none"> <li>• Finite number of competencies to train</li> <li>• Train for unpredicted situations</li> <li>• Multi scenario-based training: strengthens ability to adapt</li> <li>• More time spent on training</li> <li>• Individualized training</li> <li>• Increased level of performance in complex and evolving environments</li> </ul> <p style="text-align: center;"><b>HIGH RESILIENCE</b></p>

### CBTA: Old concept, new application

The competency-based training approach has existed since the late 1950s. It has been progressively deployed in the aviation industry since the 2000s with the Multi-crew Pilot License (MPL) introduced in 2006, which was the first CBTA program for licensing training. The first CBTA program for recurrent training was introduced in 2013 with Evidence-Based Training (EBT).

In 2016, ICAO published Amendment 5 to ICAO Doc 9868 Procedures for Air Navigation Services - Training (PANS-TRG), which introduced general provisions for CBTA. The revision of ICAO Annex 1, published in 2020, recommends the use of CBTA as a principle of training in a wide range of other aviation disciplines such as Air Traffic Control, Aircraft Maintenance, and Flight Dispatch.

The latest PANS-TRG revision, published in 2020, further develops the CBTA training method as an important tool to ensure safe operations. It requires pilots to “demonstrate resilience when encountering an unexpected event”.



## INFORMATION

In the light of the COVID-19 pandemic and its impact on our industry, IATA published the “*Guidance for post-COVID Restart of Operations: CBTA Training Solutions*”. The objective of this document is to provide guidance on training solutions to ensure a safe and efficient restart of operations after a long period of inactivity.

Additionally, Airbus introduced the Airbus Pilot Relaunch Program (APRP). The aim of the APRP is to enable flight crews of Airbus aircraft to do training to reinforce operational fundamentals after a long period without flying. The content of the training depends on the level of training requested by the Operator and on the flight crew competencies to be reinforced.

### Example of CBTA: Evidence-Based Training (EBT)

IATA launched a qualitative initiative in 2007 to review the recurrent training system for flight crews, supported by ICAO and the International Federation of AirLine Pilots’ Associations (IFALPA). It was called the Training and Qualification Initiative (ITQI) and its goal was to continuously reduce the number of incidents and accidents. Previous to this, training was designed in the 1960s when only the second and third generation of commercial jet aircraft were flying, whereas air transport traffic today is mostly made up of third and fourth generation commercial jet aircraft. More information on the four generations of commercial jet aircraft is available on the **Airbus accidents statistics website**. This modernization of the fleet, and the increasing role of human factors, meant that reevaluating the training tools and methods was necessary.

This initiative relied on various data sources such as flight data analysis, air safety reports, Line Observation Safety Audits (LOSA), which includes flight observations, and more specifically threat and error management observations. It also relied on training criticality surveys, which addressed the effectiveness of training by highlighting the difference between the situations faced in line operations and in training. These sources, along with other data, were collected as evidence to evaluate the relevance of training depending on the generation of commercial jet aircraft the pilot is flying.

The result of this analysis is the *ICAO Doc 9995 Manual of Evidence-Based Training (EBT)* published in 2013. It focuses on a competency-based training approach, giving more emphasis to non-technical skills and Crew Resource Management (CRM) and depending on the generation of aircraft flown. More information on the EBT concept can be found in the “**Learning From the Evidence**” Safety first article, published in July 2014.

IATA published the *Manual of EBT* together with the *EBT Implementation Guide*, which already highlighted the importance of developing resilience training. IATA and ICAO were supported in their study with in-service data coming from aircraft manufacturers including Airbus and from Operators. This data formed the *EBT Data Report*, which allowed for a realistic evaluation of the relevance of the training. ■



**Website**  
Airbus accidents statistics



**Article**  
Learning From the Evidence

## BEST PRACTICES FOR TRAINING RESILIENCE

### Helping flight crews to be aware of their own resilience

The goal of CBTA is to be able to manage any situation, even situations that trainees have not been specifically trained for. Being aware of how well they perform in unpredictable situations can help the flight crew to develop their confidence and build their resilience. The instructor is there to support the trainees to develop this awareness. For example, the instructor can highlight how applying procedures and using checklists when appropriate is already one way to mitigate threats and errors. This maintains an acceptable level of safety and is an illustration of resilience. Similarly, another example of resilience is anticipating crosswind before descent and then reviewing the corresponding procedures to be better prepared for landing.

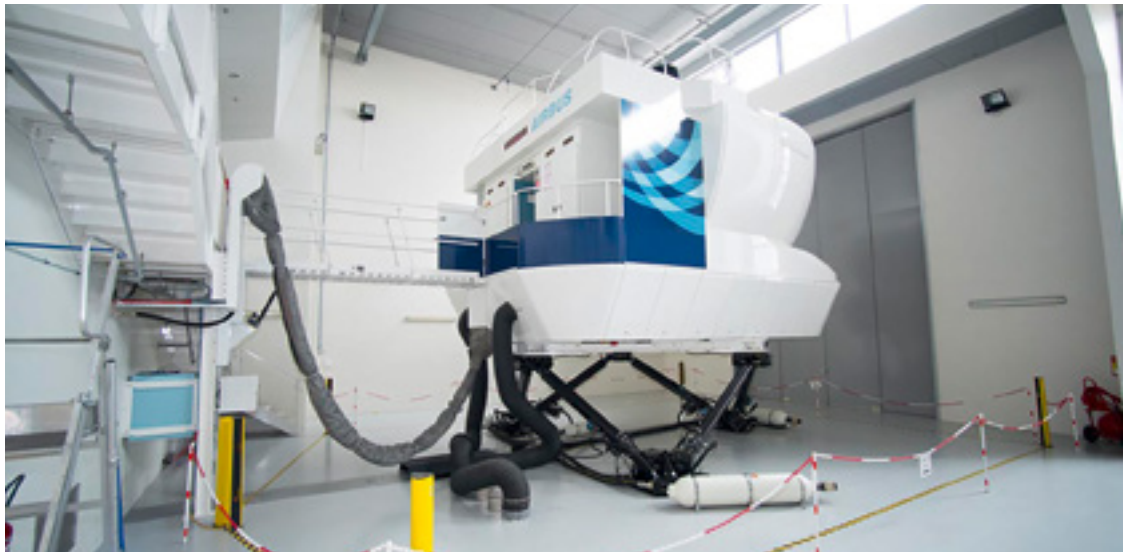

### Recognizing and managing the startle effect

The use of full-flight simulators is not always necessary for resilience training. An awareness session about the psychological and physiological effects of “startle” can help pilots better understand the “startle effect”. They will be able to better recognize how they respond to unexpected disruptions in their daily routines and how they react to them. Knowing the physiological effects of ‘startle’ and controlling the initial response is an essential part of increasing a pilot’s own resilience and can prevent incorrect actions on the aircraft controls.



**Video**

“The Two Sides of Fear”



## INFORMATION

For more information about startle management, you can watch the video “**The Two Sides of Fear**” available on Airbus Worldwide Instructor News (WIN) website.

## Exposing flight crews to different situations

Engine failure, autopilot disconnection in cruise, turbulence, and wake vortex encounters are some examples of situations that flight crews should be exposed to when training for resilience. Increasing the variety of situations will reduce the risk of a pilot forming behaviors that are too rigid due to the repetition of the same situations and affecting their ability to adapt to new ones. Behaviors that are too rigid or automatically applied are much more difficult to transfer to an unexpected situation.

All Airbus Type Rating courses today offer multiple-choice scenarios, both operational and technical that the instructor can select. Multiple-choice scenarios provide the element of surprise to the flight crews and increase the variety of unexpected scenarios they can encounter. This allows for the design of better resilience training and assessment.

## Adapting training scenarios

The training scenarios should be well suited to the existing competencies of the flight crews. The instructor should adapt the training scenario based on the pilot's previous assessment. It is recommended that the instructor end the training session in a positive manner with a situation that the pilot will be confident to manage with a successful outcome.

## Importance of the debriefing

### Highlighting the positive

Increasing resilience relies heavily on the principle of reinforcing confidence. Highlighting the positive outcomes during a debriefing session is essential to this. Instructors are still required to record notes of any observations during the training session, to give feedback, and to focus on them in future training sessions. However, to only focus on the errors or inadequacies of the pilot's performance can have the unintended effect of decreasing their level of resilience.

### Facilitation technique

A simple way to ensure a constructive debriefing session is to allow the trainees to debrief themselves and reflect on what they have done to reach a safe outcome. The instructor may notice that they will not need to add many additional observations. They can, therefore, pay more attention to developing mitigation strategies together with the trainee to avoid any deficiencies in the future. This will help build the trainee's confidence and increase their level of resilience.

### CBTA is still relevant

If the instructor considers that the facilitated debriefing is not sufficient to correct the root-cause of the problem, they should recommend further training. It is advisable to select a different exercise that requires the trainee to use the same competencies to manage the situation. ■

“ A simple way to ensure a constructive debriefing session is to allow the trainees to debrief themselves ”



## BEST PRACTICE

---

Debriefing after each flight is also an opportunity to increase the flight crew's resilience by letting them reflect on how they react to threats and errors, and how they apply their competencies to keep sufficient margins of safety. The Flight Crew Techniques Manual (FCTM) is being updated to include a new part on how to conduct operational briefings. This new part is already available for A350 aircraft, and it will be available for A320/A330/A340/A380 aircraft at the end of 2021 and for A300-600/A310 aircraft in 2022. Debriefing is a powerful tool for long-term safety management.

---

**CONTRIBUTORS:****Florence BURRATTO**

Expert in Human Factors  
for Flight Operations  
Customer Support

**Capt. Robert GRAEF**

Head of Pedagogy  
and Flight Operations  
Standards  
Customer Support

**With thanks to Capt. Craig Hildebrandt from Product Safety, Thomas Gobeaut from A300/A310 Flight Operations Support, Eric Denoux from Flight Training, Capt. Christian Norden, and Claire Pellegrin.**

The term “resilience” has become widely used in recent years. It is now used in every field of activity, not only in aviation. Resilience describes a flight crew's ability to recognize, absorb, and adapt to disruptions according to EASA's definition of resilience.

Resilience relies on two pillars: competence and confidence. It is the combination of a flight crew's confidence to manage unexpected situations and how they apply their competencies in such situations that reflects their level of resilience. The goal of resilience training is to enable the flight crew to recover performance as quickly as possible after they experience the ‘startle effect’ caused by an unexpected situation.

The preferred training methodology to strengthen a pilot's level of resilience is the CBTA approach. Instead of following the traditional task-based approach, which requires checking a continuously growing list of tasks, CBTA focuses on a limited number of competencies applied to a variety of situations. The objective of CBTA is to train pilots to manage any unforeseen situation during flight, and therefore, to develop their resilience when faced with any unexpected events.

EBT is a CBTA program that focuses on recurrent training for pilots. It was developed in 2014 by ICAO to increase the level of flight safety through resilience training for pilots, and it has since been adopted by Airbus for all type ratings.

The instructor has a key role to play in supporting pilots to strengthen their level of resilience during training sessions. In addition to developing and assessing each trainee's competencies, the instructor needs to be mindful to reinforce the pilot's confidence. This is a key component for increasing resilience. Exposing flight crews to a variety of situations, adapting training scenarios to their current level of performance, debriefing using the facilitation technique, or ending the training session on a positive outcome, are just some of the recommendations instructors should follow to increase the level of resilience in their trainees.

Targeting a high level of resilience for pilots, but also for cabin crews, air traffic controllers, maintenance personnel and all actors of the air transport system is crucial to ensure an even higher level of safety especially when facing unpredictable or unexpected situations.





# Lining Up with the Correct Glide Slope

The Instrument Landing System (ILS) is accurate and reliable, but the ILS antenna design today causes secondary glide slopes to appear above the primary glide slope. Flight crews must be aware of this phenomenon to prevent unwanted aircraft behavior during an ILS glide slope capture.

This article explains the phenomenon of secondary glide slopes and their effect on aircraft systems. It provides guidance and examples that show how flight crews can prevent capturing a secondary glide slope. It also describes the protections on Airbus aircraft that limit the effect of an unintended secondary glide slope capture on the aircraft trajectory.

This article is also available on [safetyfirst.airbus.com](https://safetyfirst.airbus.com) and on the Safety first app for iOS and Android devices.



Capturing a secondary glide slope can lead to unexpected aircraft behavior. It is important for flight crew to be aware of the phenomenon and to know how to prevent secondary glide slope capture. Some typical scenarios, based on real cases, with their associated effects on the aircraft trajectory and their prevention means are described below.

## CASE 1: EXCESSIVE PITCH DOWN DURING ILS GLIDE SLOPE INTERCEPTION FROM ABOVE

The first case happens during an **ILS glide slope interception from above**. The aircraft descends in **OP DES** guidance mode (fig.1). The air traffic controller clears the flight crew for approach. ① The flight crew consequently presses the **APPR** pushbutton. ② The PFD indicates a glide slope below the aircraft, as expected by the flight crew. ③ A few seconds later, the **G/S\*** mode engages and the autopilot orders a pitch down command toward the glide slope. The pitch down command continues until it reaches the 13° pitch down limit for autopilot disconnection ④. The flight crew must take over to recover the situation and perform a go-around.

**(fig.1)**

Event of excessive pitch down during its glide slope interception from above

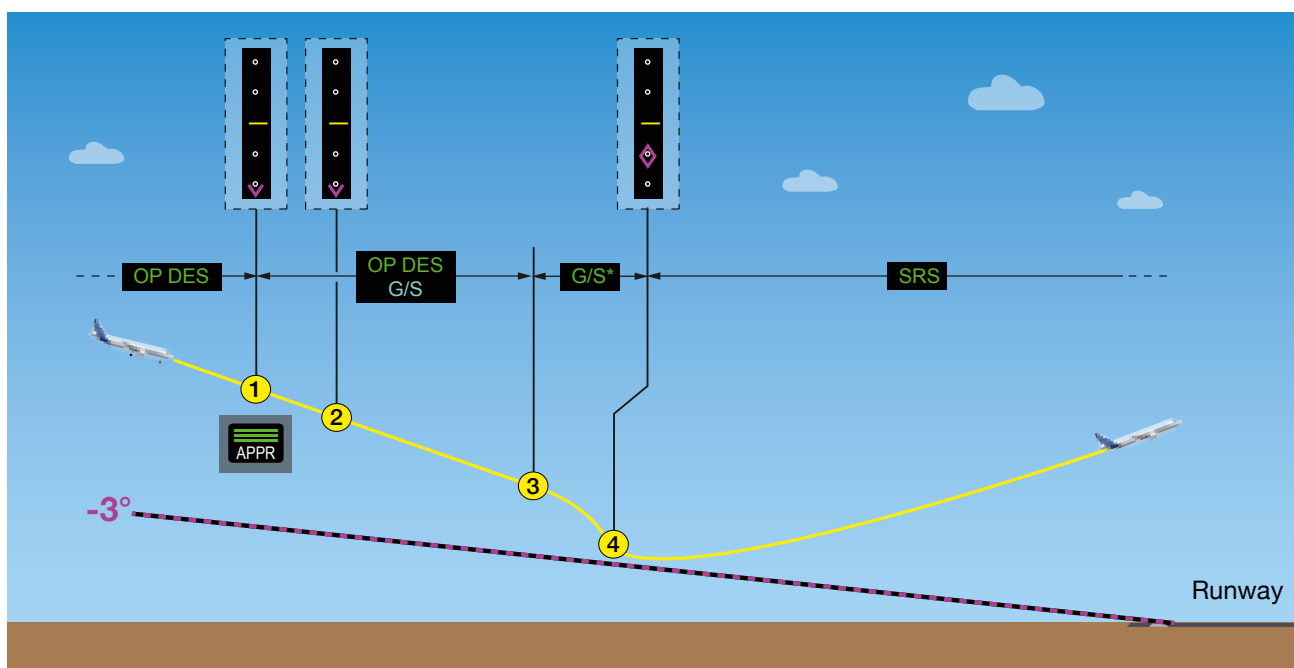

### A secondary glide slope capture was the cause of this event

Analysis of the data from the flight recorders enabled us to identify that this excessive pitch down order was caused by an initial capture of a secondary glide slope that caused undue early engagement of the **G/S\*** guidance mode. Before explaining what happened, we need to know what the secondary glide slope phenomenon is.

### ILS Secondary Glide Slope Phenomenon

Secondary glide slopes are an inevitable characteristic due to the ILS antenna design. When an aircraft flies well above the main glide slope, the glide slope deviations displayed on the PFD will refer to the nearest glide slope, which may be a secondary glide slope instead of the primary one. This can lead both the flight crew and the autopilot to erroneously consider the secondary glide slope as the reference for the final descent.

There are several types of ILS glide slope antennas that use different technologies. They can be classified into two theoretical categories: “Inverted” glide slope and “repeated” glide slope. This considers the associated impact on the autopilot behavior and the indications observed by the flight crew.

#### ILS with “inverted” secondary glide slopes

This category of glide slope antennas inverts the orientation of the glide slope at every other glide slope. For example, in the case of a  $-3^\circ$  glide slope, secondary glide slopes exist at  $-9^\circ$ ,  $-15^\circ$ ,  $-21^\circ$  and every other  $6^\circ$ , but the glide slopes at  $-9^\circ$ ,  $-21^\circ$  and every other  $12^\circ$  are inverted. The PFD glide slope deviations are inverted for these glide slopes, i.e. the aircraft is seen above the glide slope when it is below and vice versa (fig.2).

**(fig.2)**

Theoretical representation of a main  $-3^\circ$  ILS glide slope and its inverted secondary glide slopes (only the secondary glide slopes at  $-9^\circ$ ,  $-15^\circ$ , and  $-21^\circ$  are represented for clarity and the angles are represented at twice their actual size)

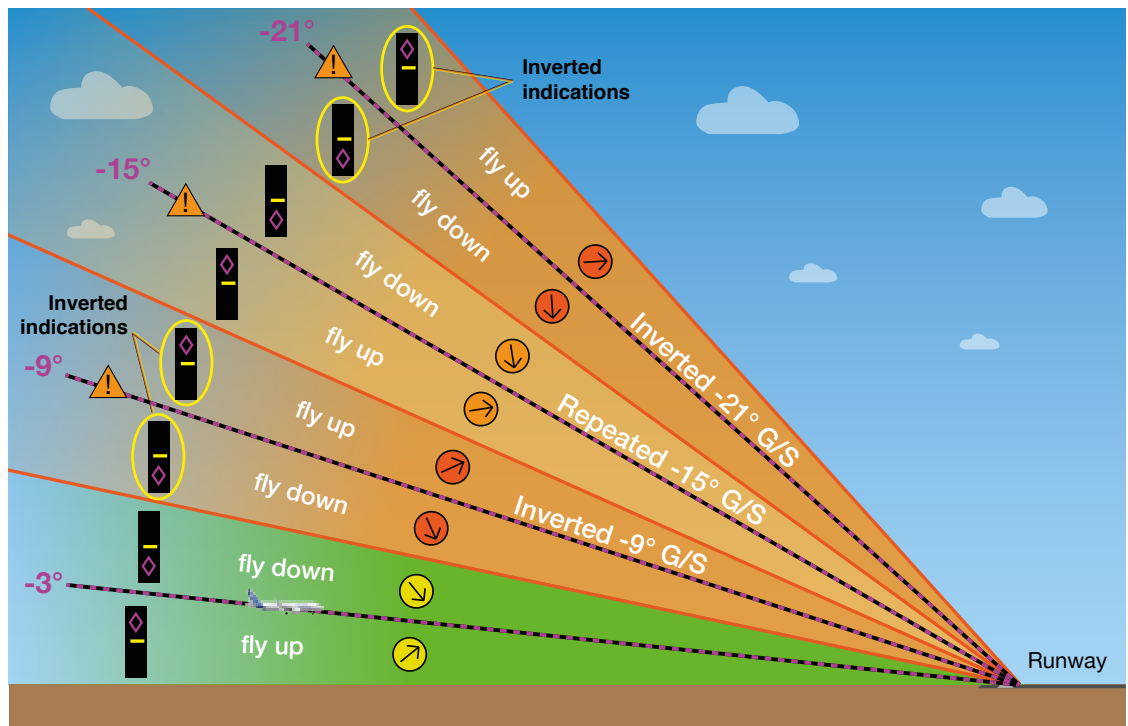

### ILS with only “repeated” secondary glide slopes

This category of antennas has only repeated glide slopes above the main glide slope (**fig.3**).

For example, in the case of a  $-3^\circ$  glide slope, repeated secondary glide slopes exist at  $-9^\circ$ ,  $-15^\circ$ ,  $-21^\circ$  and every other  $6^\circ$ .

### (fig-3)

Theoretical representation of a main  $-3^\circ$  ILS glide slope and its repeated secondary glide slopes (only the secondary glide slopes at  $-9^\circ$ ,  $-15^\circ$ , and  $-21^\circ$  are represented for clarity and the angles are represented at twice their actual size)

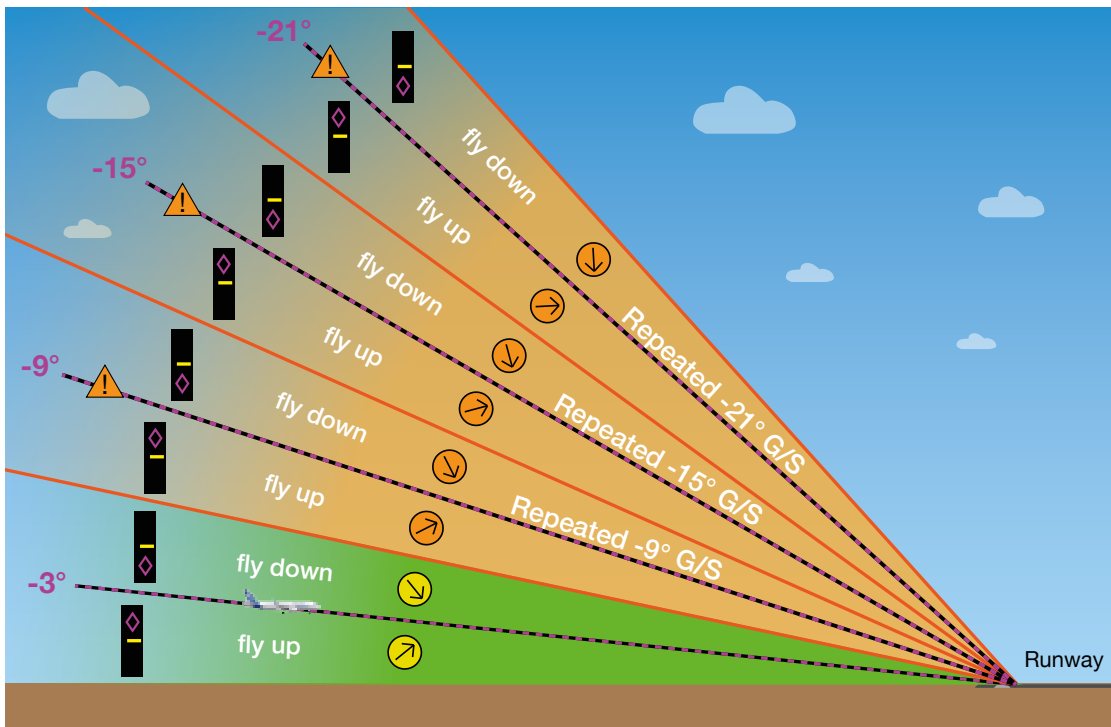

### NOTE

There is no way for flight crews to know which category of ILS antenna (either with “inverted” or “only repeated”) is used at their destination airport.

Note that no cases of unexpected behavior due to ILS with “only repeated” glide slopes were reported to Airbus, therefore the examples shown only describe scenarios of ILS with inverted glide slopes.

### Variable measured signal characteristics at the boundary between two glide slopes

Test flights performed to analyze the secondary glide slope structures showed that the real characteristics of the glide slopes may differ from the above theory, in particular in the boundary region between two glide slopes (shown as amber lines in **fig.2** and **fig.3**). Therefore, it is difficult to predict the behavior of the autopilot in these zones.

# OPERATIONS

## Lining Up with the Correct Glide Slope

### Possible inappropriate engagement of **G/S\*** when crossing the boundary between two glide slopes.

When an aircraft crosses the boundary between two glide slopes (at approximately  $-6^\circ$ ,  $-12^\circ$ ,  $-18^\circ$ , etc...), temporary deviation “jumps” and/or a false deviation value of zero can trigger inappropriate engagement of the **G/S\*** capture mode. This can happen when the approach guidance modes are armed, meaning that the **APPR** (LAND for A300-600/A310) pushbutton was previously pressed. The physical characteristics of the glide slope or the speed and angle at which the aircraft crosses the boundary, will influence if engagement occurs. Note that this phenomenon is possible for both the “repeated” and “inverted” types of secondary glide slope. Therefore, it is difficult to anticipate the autopilot behavior when crossing the boundary between two glide slopes. ■

**(fig.4)**

Example of the ICAO envelope for an ILS with a  $-3^\circ$  glide slope

### The ICAO envelope for glide slope signal quality.

ICAO guidelines provide recommendations for ensuring the quality of the ILS glide slope signal. Periodic checks on all ILS equipped runways ensure that the **ILS signal quality is at the required level inside a defined envelope**.

Capturing the ILS glide slope within this envelope ensures that the aircraft is within the area of influence for the primary glide slope. It also ensures that the ILS signal is of sufficient quality to ensure a normal ILS glide slope capture. The ICAO envelope (**fig.4**) is within:

- **10 NM** from the runway threshold
- **$\pm 8^\circ$  laterally** from the runway centerline
- **$0.3 \times \theta$  up to  $1.75 \times \theta$**  ( $\theta$ , being the nominal glide path angle).

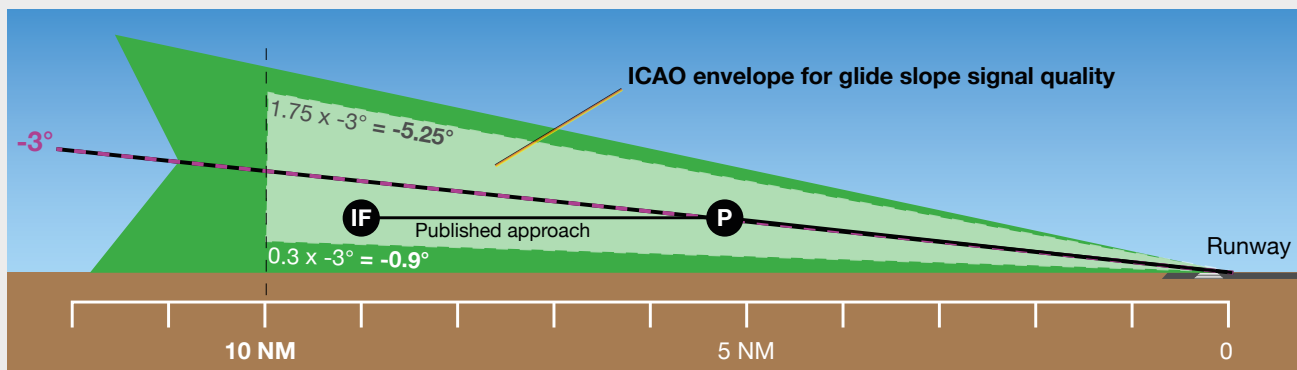

## Analysis of the excessive pitch down event

With the secondary glide slope theory in mind, we can review the scenario of the event to better understand what happened.

The aircraft is in **OP DES** (LVL/CH for A300-600/A310) mode (**fig.5**). **1** The flight crew presses the **APPR** (LAND for A300-600/A310) pushbutton well above the  $-3^\circ$  glide slope, within the  $-9^\circ$  zone of influence. The aircraft is nearer to the  $-9^\circ$  secondary glide slope but far enough from it so that the **G/S** mode is armed but not engaged. **2** The inverted glide slope deviations mean the flight crew cannot detect that their aircraft is in the zone of influence of an inverted secondary glide slope. The glide slope indicated below the aircraft is as expected Safety first - December 2021 Page 5/12 by the flight crew. **3** When the aircraft crosses the  $-6^\circ$  boundary between the  $-3^\circ$  and  $-9^\circ$  glide slopes, a temporary false deviation value of zero received by the MMR triggers the undue engagement of the **G/S\*** mode. Therefore, the autopilot orders a pitch down command toward the  $-3^\circ$  glide slope. As the aircraft is flying high above the  $-3^\circ$ , there is sufficient time for the pitch to reach the  $13^\circ$  pitch down limit for autopilot disconnection **4**. In manual flight, the flight crew must take over to recover the situation and perform a go-around.

**(fig-5)**

Excessive pitch down due to undue G/S\* activation during ILS glide slope interception from above

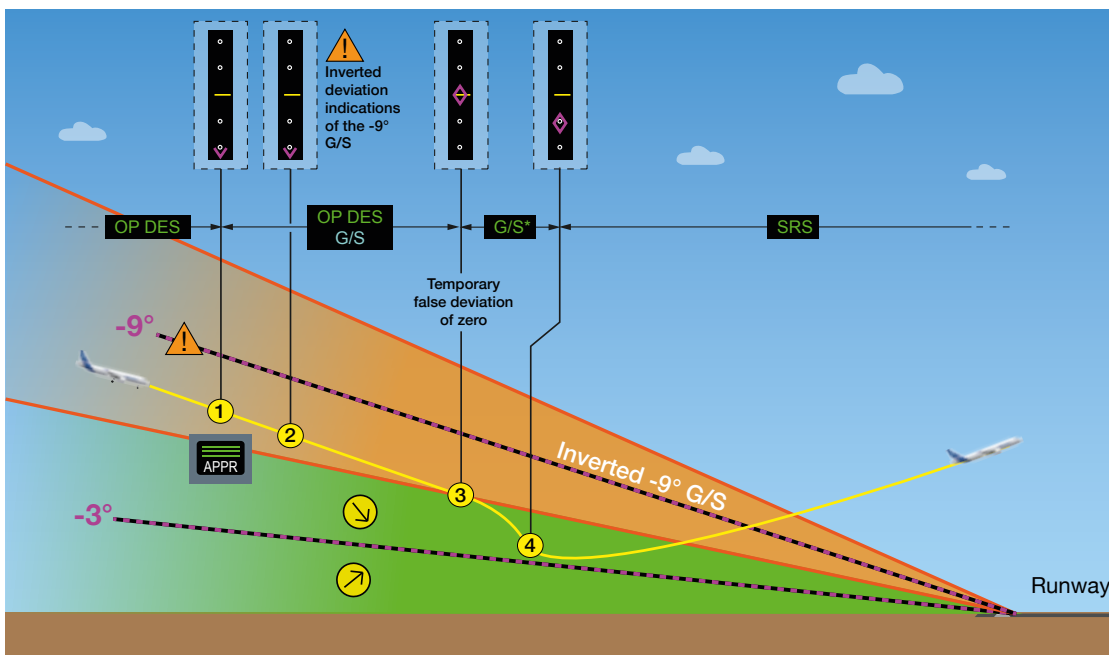

### Prevention: Quick check of the aircraft position before pressing the APPR pushbutton when intercepting a glide slope from above.

When intercepting the glide slope from above, the flight crew should ensure that the aircraft is below the upper boundary of the main glide slope before they press the **APPR** (LAND for A300-600/A310) pushbutton. This boundary is located at approximately twice the value of the primary glide slope angle (approximately  $-6^\circ$  in our example). This ensures that the capture will be done on the correct glide



# OPERATIONS

## Lining Up with the Correct Glide Slope

**(fig.6)**

For ILS glide slope interception from above, a quick altitude vs. distance check ensures that the aircraft is below the upper boundary of the primary glide slope before pressing the APPR (LAND for A300-600/A310) pushbutton

slope. As a rule of thumb, a quick altitude vs. distance check can be done to ensure that the aircraft is below the upper boundary of the main glide slope. The aircraft altitude above airport elevation (in ft) should be less than 6 times the distance to runway (in NM) multiplied by 100 (**fig.6**):

$$h(\text{ft AAL}) < 6 \times d(\text{NM}) \times 100$$

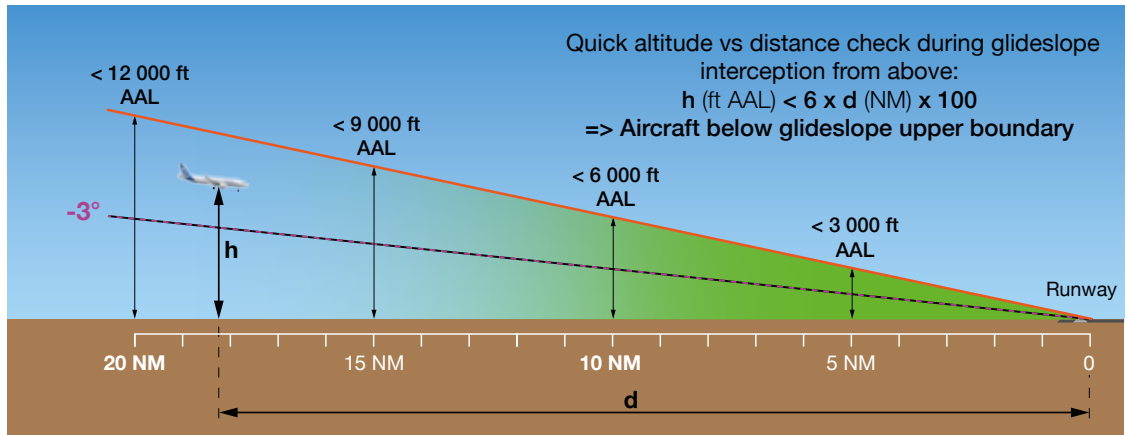

### Check of the glide slope in standard glide slope interception (from below)

Similarly to the above quick check, the flight crew can estimate if they are intercepting the correct glide slope during a standard glide slope interception from below using the formula:  $h(\text{ft AAL}) = 3 \times d(\text{NM}) \times 100$

### FCOM procedure: guidance mode for glide interception from above.

In the described event and in the next one, the flight crew uses the **OP DES** guidance mode to intercept the glide slope from above. This is not recommended in the FCOM. As per the FCOM "Glide interception from above" procedure and the FCTM, after the aircraft is established on the localizer, the flight crew should press the **APPR** pushbutton, set the FCU altitude above the aircraft altitude, and then select the **V/S** mode to intercept the glide slope. ■



## CASE 2: EXCESSIVE PITCH UP DURING ILS GLIDE SLOPE INTERCEPTION FROM ABOVE

In this second case, an aircraft also intercepts the glide slope from above (fig.7).

① The flight crew presses the **APPR** (LAND for A300-600/A310) pushbutton but does not set the FCU altitude target above the aircraft altitude, because it is usually requested by the SOP for an ILS approach. The aircraft converges toward the  $-3^\circ$  glide slope, but reaches the target altitude before the **G/S\*** can engage. ② The aircraft levels off and starts to diverge from the  $-3^\circ$  glide slope and to converge with the  $-9^\circ$  secondary glide slope. ③ When crossing the  $-6^\circ$  boundary between the  $-3^\circ$  and  $-9^\circ$  glide slopes, the MMR receives a temporary false deviation value of zero, but it is not sufficient to engage the **G/S\*** mode. ④ The  $-9^\circ$  glide slope is inverted, and as a result, the glide slope deviation indications show the glide slope below the aircraft. ⑤ When the aircraft crosses the  $-9^\circ$  secondary glide slope, the **G/S\*** guidance mode engages. The autopilot then commands a pitch up when the aircraft crosses the  $-9^\circ$  glide slope, due to its inversion. In this case, the flight crew has no choice but to perform a go-around ⑥.

(fig.7)

Excessive pitch up command due to inverted secondary glide slope capture

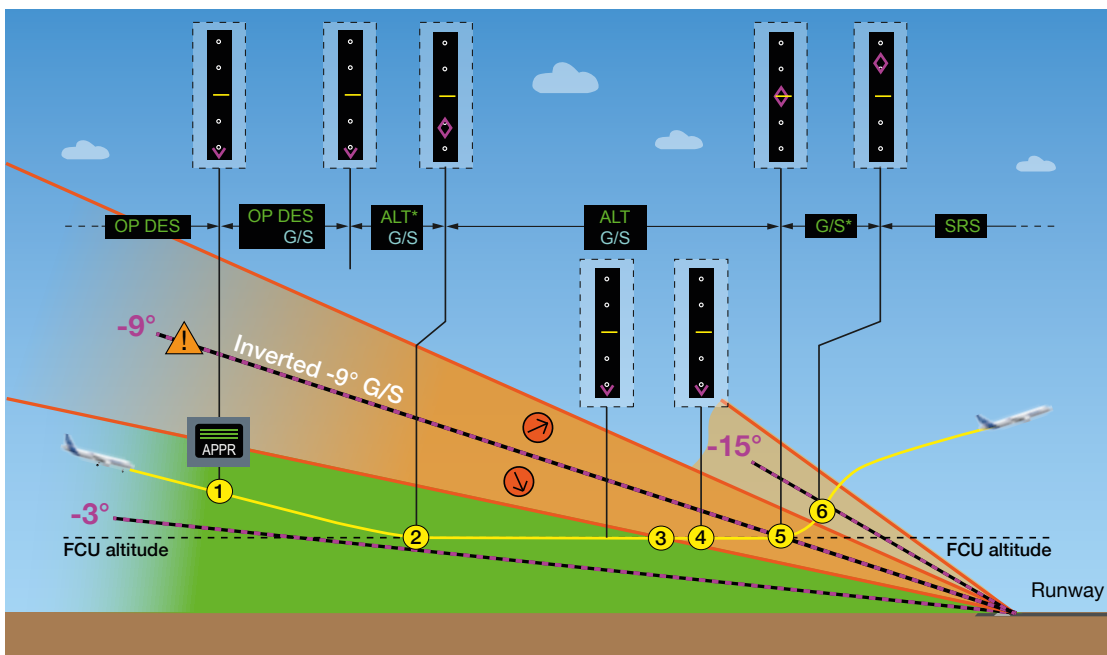

### Prevention: Correct FCU altitude setting during glide interception from above.

The "glide interception from above" FCOM procedure requests the flight crew to select the FCU altitude above aircraft altitude. This should be done after the flight crew presses the **APPR** (LAND for A300-600/A310) pushbutton to prevent unwanted **ALT\*** engagement and possible level-off that can lead to the capture of a secondary glide slope as shown in this example. This important step of the procedure can prevent such an occurrence. ■

## CASE 3: UNEXPECTED PITCH UP DURING A DISCONTINUED APPROACH

(fig.8)

Unexpected pitch up during a discontinued approach

1 The flight crew needs to interrupt their glide slope interception from above at the request of ATC, due to unavailability of the runway (fig.8). 2 The flight crew presses the VS-FPA knob-selector to level off but does not press the APPR pushbutton to disarm the G/S guidance mode, which is usually expected during a discontinued approach. The aircraft levels off as expected. This now follows the same scenario as described in case 2: 3 When the aircraft crosses the -6° boundary between the -3° and -9° glide slope, the duration of the temporary false deviation value of zero is short enough not to engage the G/S\* mode. 4 When the aircraft crosses the -9° glide slope, the G/S\* mode engages and commands a pitch up due to the inversion of the secondary glide slope. 5 The flight crew must take over and perform a go-around.

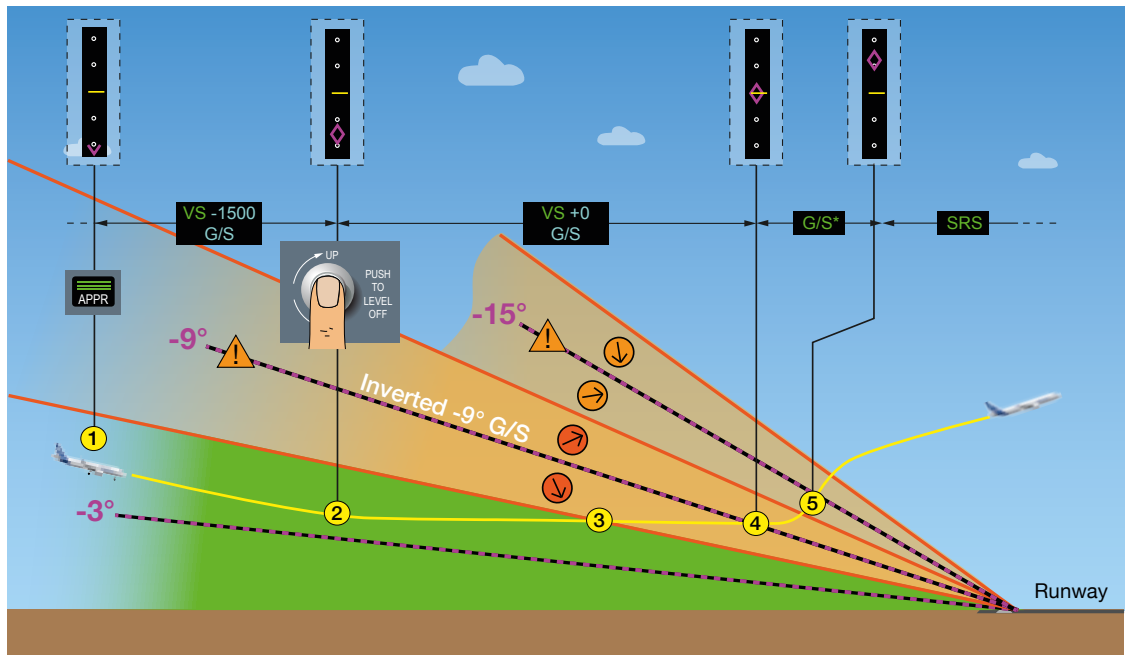

### Prevention: Disarming of the approach guidance mode during discontinued approach procedure.

After the flight crew announces “CANCEL APPROACH”, they must remember to press the APPR pushbutton to disarm the G/S guidance mode as per the “discontinued approach” SOP. This will prevent engagement of the G/S\* and G/S modes on a secondary ILS glide slope. ■

# AVAILABLE PROTECTIONS

Airbus developed some protections to limit the Flight Path Angle (FPA) in the case of a secondary glide slope capture by doing some modification on the autopilot flight guidance laws. These are available on A330, A340, A350, and A380 aircraft and limit the maximum Flight Path Angle (FPA) between 0° and -6° in **G/S\*** mode. A320neo family aircraft have FPA protection in both **G/S\*** and **G/S** modes.

The protections referred to above are not available on A220, A300, A310, and A320ceo aircraft at the time of publishing. The same protections will be introduced on A320ceo, and the protections that are already available on A330, A350, and A380 aircraft will be updated with the next Flight Guidance computer standard update to make these protections available in both **G/S\*** and **G/S** modes. A similar protection will be added in the **GS** guidance mode of A220 aircraft at the opportunity of a future avionics build. ■

**(table 1)**

Availability of protections in **G/S\*** and **G/S** guidance modes to prevent excessive pitch if a capture of a secondary glide slope occurs.

Note: Data correct at time of publication in December 2021.

Aircraft	Current Design		Future Design		
	Protected Modes -6° < FPA < 0°	Minimum Flight Guidance Standard	Protected Modes -6° < FPA < 0°	Minimum Flight Guidance Standard	Availability Date
<b>A300, A310</b>	None	Not applicable	None	Not applicable	Not applicable
<b>A220</b>	None	Not applicable	<b>GS</b>	Avionics build 8B or later	Not yet planned
<b>A320ceo</b>	None	Not applicable	<b>G/S*</b> and <b>G/S</b>	I16 or C15 PI20 or PC22	2023 2024
<b>A320neo</b>	<b>G/S*</b> and <b>G/S</b>	Basic	<b>G/S*</b> and <b>G/S</b>	Basic	Available
<b>A330 &amp; A330neo</b>	<b>G/S*</b>	HJ1 or G1	<b>G/S*</b> and <b>G/S</b>	H7	Q1 2022
<b>A340</b>	<b>G/S*</b>	F3	<b>G/S*</b>	F3	Available
<b>A350</b>	<b>G/S*</b>	Basic	<b>G/S*</b> and <b>G/S</b>	PRIM P13	Q4 2021
<b>A380</b>	<b>G/S*</b>	P8	<b>G/S*</b> and <b>G/S</b>	PRIM P13.5	Q2 2022

### CONTRIBUTORS:

#### Hélène CARROLS

Accident/Incident  
Investigator  
Product Safety

#### Cedric

#### DESCHEEMAER

Product Safety  
Enhancement Manager  
Product Safety

#### Xavier DUREPAIRE

Training & Flight  
Operations Expert Pilot  
Customer Support

#### Nicolas MARCONNET

Avionics System  
Engineer  
Design Office

#### Lilian RONCERAY

Aircraft Control System  
Engineer  
Design Office

Secondary glide slopes are inevitable characteristics of ILS approaches. Flight crews must be aware of secondary glide slopes and their possible effect on the display of the glide slope deviations and on the aircraft trajectory. This will ensure that they react correctly in the case of a secondary glide slope capture.

Flight crews can prevent a secondary glide slope capture by following the applicable FCOM SOP.

**To intercept an ILS glide slope from above**, the aircraft should be below the boundary between the primary glide slope and the first secondary glide slope (6° for a 3° glide slope). The flight crew should then press the **APPR** (LAND for A300-600/A310) pushbutton and ensure that the FCU altitude is set above the aircraft altitude.

**In the case of a discontinued approach**, after the "CANCEL APPROACH" callout, the flight crew should press the **APPR** (ALT. HLD for A300-600/A310) pushbutton to disarm the **G/S** guidance mode as per the SOP.

Airbus developed protections for the **G/S\*** and **G/S** guidance modes to limit the flight path angle of the aircraft between 0° and -6°. This will prevent an excessive pitch command if an unwanted capture of a secondary glide slope occurs. These protections are available on many Airbus aircraft in **G/S\*** guidance modes and will be made available for most of the Airbus fly-by-wire aircraft in both **G/S\*** and **G/S** guidance modes on future flight guidance computer standards.







# Landing with Nosewheels at 90 degrees

In the past few years, several events occurred involving landing with the Nose Landing Gear (NLG) wheels turned to 90° from the aircraft centerline.

The investigations identified the root causes, which were different for each event. Mitigating actions were developed and deployed accordingly.

This article describes the outcomes of investigations into several events of aircraft landing with NLG wheels at 90° and shows why they are not related. It also recalls the corrective actions and existing operational recommendations to prevent any recurrence.

This article is also available  
on [safetyfirst.airbus.com](https://safetyfirst.airbus.com)  
and on the Safety first app  
for iOS and Android devices.



# CASE 1: NLG COMPONENT STRUCTURAL FAILURE

## Event description

In 2005, during the takeoff of an A320 family aircraft, a few seconds after landing gear retraction was commanded, the **L/G SHOCK ABSORBER FAULT** ECAM alert was triggered followed by the **WHEEL N/W STRG FAULT** ECAM alert. As a result, the flight crew was not able to retract the Nose Landing Gear (NLG). They suspected an issue with the NLG, and so they performed a flyby allowing ATC to observe the situation of the NLG. ATC confirmed to the crew that the nosewheels of the aircraft were turned at 90°. The flight crew decided to divert to an airport with a longer runway. The aircraft remained airborne to use fuel before landing. The aircraft touched down on the runway and the flight crew delayed the nosewheel touchdown by not using ground spoilers, autobrake, or applying reverse thrust. The nosewheel tires burst shortly after touchdown and the wheels on the runway generated a lot of sparks. The aircraft remained on the runway centerline. After the aircraft stopped, the flight crew deemed that it was not necessary to perform an emergency evacuation and all passengers disembarked the aircraft using stairs.

## Event analysis

There are two lugs on the upper support of the NLG shock absorber that prevent it from rotating freely in its housing (**fig.1**). The investigation showed that both lugs had sheared off and this caused the NLG to lose its centered position. This condition was immediately detected by the Landing Gear Control Interface Unit (LGCIU), which triggered the **L/G SHOCK ABSORBER FAULT** ECAM alert. The Braking & Steering Control Unit (BSCU) also detected the rotation and deactivated the Nose Wheel Steering (NWS) system. This triggered the **WHEEL N/W STRG FAULT** ECAM alert. The absence of nosewheel steering, combined with the broken anti-rotation lugs and the aerodynamic loads, enabled the NLG wheels to turn at 90° from the centerline.

It was discovered that the BSCU standard fitted to the aircraft at the time performed a greater number of steering movements during the preland checks compared to previous BSCU standards. This caused more fatigue to the 2 lugs on the upper support of the shock absorber. The internal pressure of the shock absorber was also found to be too high due to incorrect servicing during maintenance. This resulted in additional friction being applied to the NLG self-centering mechanical device, which is connected to the upper support, and eventually caused the 2 lugs to shear.

(fig.1)

Position of the 2 lugs on the upper support of the NLG shock absorber

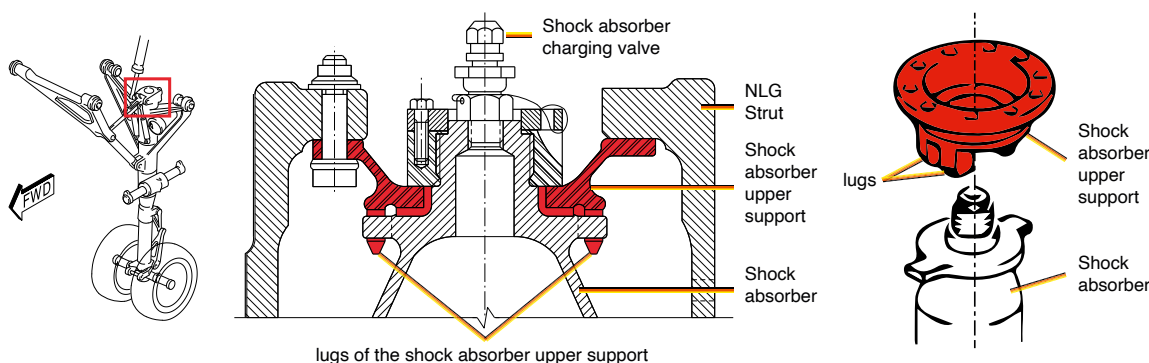

# OPERATIONS

Landing with Nosewheels at 90 degrees

## Prevention

### New BSCU Standard BSCU Standard

L4.9B was developed with a reduced number of steering movements during the preland tests. The retrofit of this new standard is complete. The BSCU standard responsible for the lug failure is no longer in service.

The temporary solution published in OEB 175/176 is no longer applicable for any of the A320 family aircraft now that the BSCU retrofit campaign is complete.



## KEYPOINT

In the case of **L/G SHOCK ABSORBER FAULT** and **WHEEL N/W STRG FAULT** ECAM alerts, no reset is authorized in flight on any A320 family aircraft.

### Correct shock absorber servicing

Before this event, it was possible to perform servicing of the shock absorber with weight on wheels but it was difficult to service the correct pressure. This led to a tendency to overpressure the shock absorber and caused increased fatigue on its upper support. NLG shock absorber servicing procedures were improved following the event to allow for easier servicing with weight off wheels using jacks on the NLG. If the shock absorber can only be serviced with weight on wheels, then the servicing task must be done again, and with weight off wheels, within the next 7 days.

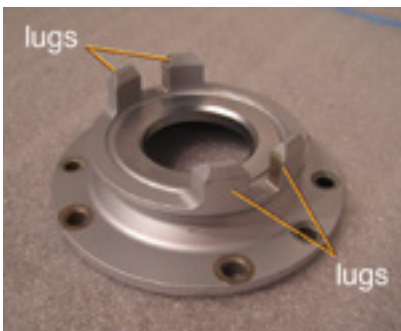

Initial design



Improved design

### (fig.2)

Differences between the initial design and improved design for the reinforced upper support of the NLG shock absorber



## BEST PRACTICE

AMM procedures must be followed when servicing the NLG shock absorber. In particular, the jacks for the NLG should be used to ensure servicing the optimum pressure for the shock absorbers. This will minimize the risk of overpressure, which can cause structural fatigue of NLG components.

### Reinforced upper support of the NLG shock absorber

Following another event that led to a landing with the NLG rotated to 90°, which had been caused by installation errors during maintenance, a new foolproof design of the NLG shock absorber was introduced (fig.2). This design prevents any lug rupture on the upper support of the shock absorber, and it is installed on all A320 family aircraft in production since 2004 and SB A320-32-1277 (Mod 34160) is available for retrofit.

## CASE 2: BSCU FAILURE

### Event description

In 2007, after the takeoff of an A320 family aircraft, the AUTOBRAKE MAX **ON** light remained on and the **BRAKES SYS 2 FAULT** ECAM alert was triggered.

During cruise, the flight crew pressed the AUTOBRAKE MAX pushbuttons. They also set the A/SKID & N/W STRG switch to OFF and back to ON, which was not requested in any ECAM/QRH/OEB procedure. This had no effect on the AUTOBRAKE MAX ON light.

On approach, the AUTOBRAKE MAX ON light remained on after the landing gear was extended and the **L/G SHOCK ABSORBER FAULT** ECAM alert was triggered. The flight crew set the A/SKID & N/W STRG switch to OFF and the AUTOBRAKE MAX ON light went off but the ECAM alerts remained.

The flight crew eventually landed the aircraft with the nosewheels turned at 90° to the centerline.

### Event analysis

It was found that the nosewheels were able to rotate up to 90° because of a hardware failure on the BSCU. The BSCU remained active but it could not be controlled and its outputs became frozen. This caused the **BRAKES SYS 2 FAULT** ECAM alert and malfunction of the AUTOBRAKE MAX **ON** light.

### Prevention

An updated design was introduced to improve the robustness of the BSCU and to allow a switch-over to the passive BSCU system when the outputs of the active BSCU system become frozen (i.e. switch from BSCU 1 to BSCU 2 or vice versa).

The retrofit of the updated BSCU standard was mandatory and is now complete. There are no reported events with a similar root cause after the affected BSCU standards were replaced. ■

## CASE 3: COMBINATION OF INDEPENDENT FAILURES

### Event description

In 2011, during cruise on an A320 family aircraft, the **NAV ILS 1 FAULT** ECAM alert was triggered followed by the **WHEEL N/W STRG FAULT** ECAM alert. The flight crew then observed that the Captain's PFD went blank for a few seconds.

On approach, the **L/G SHOCK ABSORBER FAULT** ECAM alert was triggered after extension of the landing gear. The flight crew suspected an NWS issue, so they performed a flyby for ATC to check the position of the NLG wheels. ATC confirmed that the wheels were turned 90° to the aircraft centreline. The flight crew landed the aircraft by delaying NLG touchdown as recommended in the A320 FCOM procedure, which is applicable when both the **L/G SHOCK ABSORBER FAULT** and **WHEEL N/W STRG FAULT** ECAM alerts are

triggered. The aircraft safely came to a stop and the passengers disembarked using the stairs. There were no injuries and one nosewheel tire was damaged during the event

### Event analysis

When the landing gear was extended, no steering control was available because an electrical transient in the power supply to the BSCU 1 caused a loss of steering function. The **WHEEL N/W STRG FAULT** ECAM alert was triggered. The electrical power transient was due to arcing at a connector on IDG1. Power transients affecting BSCU 1 were already observed on several previous flights.

It was also found that a maintenance task on the NLG was not correctly carried out and this resulted in the hydraulic selector valve jammed in the open position. This would usually be detected in the preland test. However, the flight crew were not able to perform the test due to a fault in the landing gear lever position. This fault was present for several previous flights.

With the selector valve jammed open, there was hydraulic pressure on the nosewheels when the nose landing gear extended. The nosewheels began to turn due to the loss of the steering function. The **L/G SHOCK ABSORBER FAULT** ECAM alert was triggered because the nosewheels were not centered. BSCU System 1 switched to System 2, but the NWS system remained inactive as it detected that the nosewheels were not centered. The nosewheels continued to rotate to 90°.

### Prevention

#### Fault classification

In the case of a fault of the landing gear lever position, the **BRAKES SYS 1(2) FAULT** ECAM alert is now triggered. This improvement is available from the BSCU Standard L4.10. It is installed on all A320 family aircraft in production since 2016 and SB A320-32-1432 is available for retrofit.

#### BSCU standard

Since the introduction of BSCU Standard L4.9B, the BSCU now centers the NLG wheels in case no preland tests are performed. The retrofit of this new standard is completed.

#### “Display Unit failure” QRH procedure

In this event, the power transient that affected the BSCU was not sufficient to switch to the BSCU 2 sooner, which would have prevented the NLG from turning to 90°.

If the PFD flickers with no **ELEC GEN 1(2) FAULT**, the flight crew should apply the “Display Unit Failure” QRH abnormal procedure. If the Captain’s PFD is affected, GEN 1 should be set to OFF, and if the First Officer’s PFD is affected, GEN 2 should be set to OFF. The application of this procedure forces the BSCU to switch from BSCU 1(2) to BSCU 2(1). ■



# CASE 4: WATER INGRESS IN NLG STEERING SENSORS

## Event description

In January 2021, during the approach of an A320 family aircraft, the **L/G SHOCK ABSORBER FAULT** and **WHEEL N/W STRG FAULT** ECAM alerts were triggered after extension of the landing gear. The flight crew set the A/SKID & N/W STRG switch to OFF and back to ON again even though it was not requested in any ECAM/QRH/OEB procedure. The flight crew landed the aircraft and delayed the NLG touchdown as long as possible, as recommended in the A320 FCOM procedure applicable when both the **L/G SHOCK ABSORBER FAULT** and **WHEEL N/W STRG FAULT** ECAM alerts are triggered.

After NLG touchdown, both NLG tires burst and the aircraft stopped on the runway. There were no injuries. The NLG wheels were turned to 90° from the aircraft centerline and skid marks of more than 1200 m long were found on the runway (fig.3).

## Event analysis

During inspection of the NLG after the event, water was found in the two Rotary Variable Differential Transformers (RVDTs). These two sensors provide the angle of the NWS position to the BSCU. Three days before the event, the aircraft was cleaned during a maintenance C check. The water ingress in the RVDTs most probably happened at this time.

A ferry flight was performed after the C check and cleaning. Analysis of the recorder data showed that one RVDT was blocked during this flight. It is likely that this was due to the water in the RVDT freezing at altitude but was probably unblocked as the ice broke up upon landing. A steering offset resulted from this flight and remained for the next 7 flights.

The steering offset was at almost 2° during taxi-out on the flight when the event occurred. The flight crew kept the aircraft from veering off course and continued with the takeoff.

The **L/G SHOCK ABSORBER FAULT** and **WHEEL N/W STRG FAULT** ECAM alerts were triggered when the landing gear extended. The NWS was already at an angle that was too excessive to be corrected by the normal mechanical self-alignment of the wheels.

When the flight crew inappropriately cycled the A/SKID & N/W STRG switch, they reactivated the BSCU and hydraulic pressure was supplied to the steering actuator. During the preland test, the BSCU could not centre the nosewheels because of the faulty sensor and the angle of the NWS position was already too excessive. This resulted in the nosewheels rotating further toward 90° before landing.

## Prevention

### Compliance with the AMM/MP tasks for aircraft washing

AMM/MP tasks for NLG washing must be followed (12-21-11 “External Cleaning”, which refers to AMM/MP 32-21-00 “Cleaning of the Nose Landing Gear”). These tasks clearly warn against the use of high-pressure hoses and provide details on protections to be used.



**(fig.3)**  
View of the NLG  
after landing





## Article

Aircraft Protection during Washing and Painting



## INFORMATION

For further information on aircraft washing, an OIT (ref. 999.0042/10) is available on the AirbusWorld portal and the “**Aircraft Protection during Washing and Painting**” Safety first article was published in January 2014, highlighting the importance of correctly applying the washing and painting procedures, including the washing of NLG.

### Operations with a nosewheel steering offset

The “Operation with Nosewheel Steering Offset” A320 FCOM supplementary procedure states that the flight crew should not attempt to take off with an offset exceeding 1.5°. The nosewheel steering offset is determined based on the rudder trim input necessary to cancel the tendency for the aircraft to veer on taxi out.

### No system resets when not authorized

The flight crew must only perform authorized reset procedures in flight. They are described in the System Reset table of the A320 QRH. If the flight crew performs a reset that is not listed in this table it could lead to unintended and serious incidents. ■



## Article

System Reset: Use with Caution



## KEYPOINT

The flight crew must only attempt authorized resets as per the System Reset table in the A320 QRH/FCOM. Unauthorized resets can have dramatic consequences. More information about authorized system resets is available in the “**System Reset: Use with Caution**” Safety first article.

## CASE 5: 180° TURN WITH NLG INOPERATIVE BEFORE TAKEOFF

### Event description

In March 2021, an A320 family aircraft was dispatched with the NWS inoperative (MEL item 32-51-01 “Nose Wheel Steering Control System”). This was due to a failure detected by the BSCU. The **WHEEL N/W STRG FAULT** ECAM alert was triggered during engine start as expected for the dispatch under the MEL.

The MEL operational procedure states that the flight crew must avoid sharp turns when the NWS is inoperative. Differential braking and asymmetric thrust were used to steer the aircraft during the taxi-out. The flight crew then performed a sharp 180° turn to align the aircraft on the runway contrary to the conditions of the MEL. After liftoff, the **L/G SHOCK ABSORBER FAULT** ECAM alert was triggered and the landing gear lever was jammed in the DOWN position. The flight crew performed an In-Flight Turn Back (IFTB) and landed the aircraft. The NLG had rotated to 90° and both NLG tires burst (**fig.4**).



(fig.4)

View of the NLG after landing

## Event analysis

The NLG wheels were in free-to-castor mode (**fig.5**) because of the inoperative NWS.

### Free-to-castor mode

In free-to-castor mode, the NLG wheels will return to 0° after up to 15° of steering due to the self-centering effect offered by the rake angle of the leg. Between 15° and 25°, the wheels will return to 0° but with more difficulty. If the NWS steering angle exceeds 25°, then NLG wheels will rotate toward 90°.

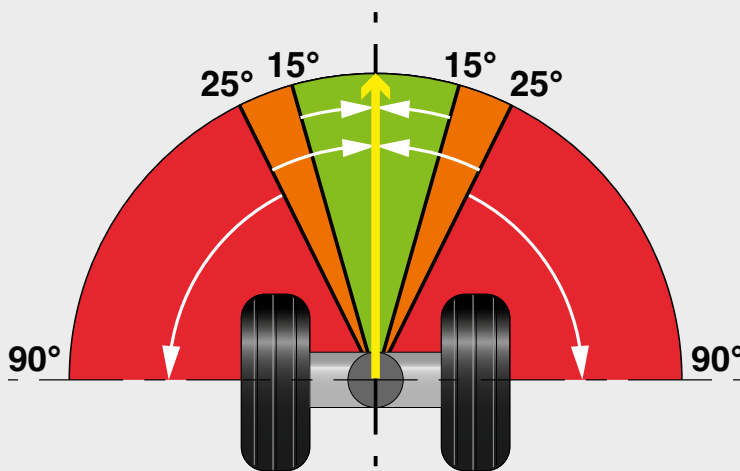

**(fig.5)**

Ability of the NLG wheels to self-center when in free-to-castor mode

Analysis of recorder data showed the evolution of the NWS angle during the taxi-out, which resulted in a U-turn. The NLG wheels remained below 15° during the first left turn and naturally returned to the centered position. During the right turn, the angle of the wheels was more than 25°, which means they will continue rotation towards the 90° position at the end of the sharp 180° turn. The wheels remained in the 90° position during the takeoff roll and upon landing.

The **L/G SHOCK ABSORBER FAULT** ECAM alert was triggered at takeoff because the nosewheels were not centred at 0°. This prevented the flight crew from retracting the landing gear.

**(fig.6)**

Illustration of the 180° turn performed during the event

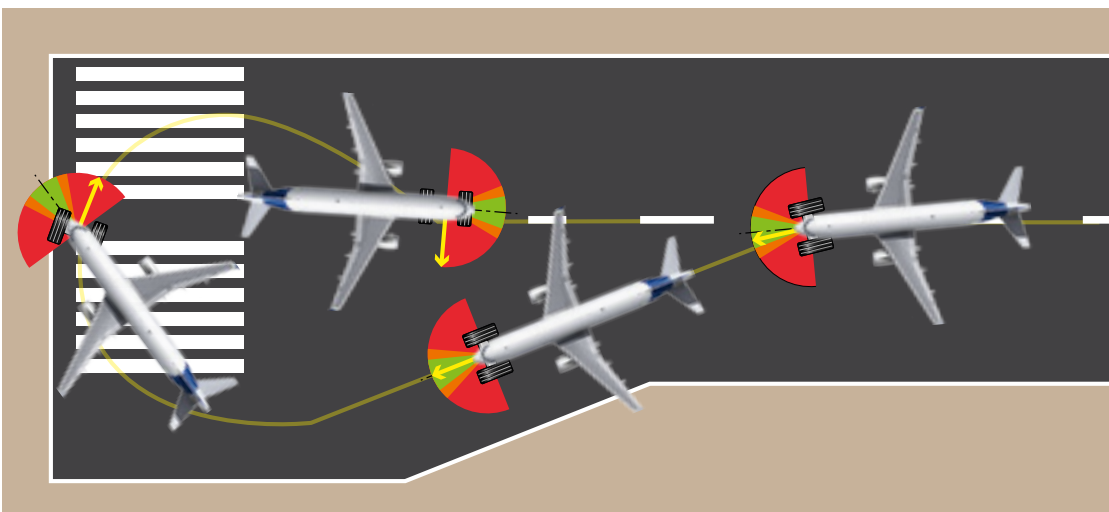

### Prevention

There were very few cases of dispatch with inoperative NWS on A320 family aircraft reported to Airbus over the last 15 years. Dispatching an aircraft with an inoperative NWS requires operational precautions that are explained in the associated operational procedure.

Even if the safety analysis shows that an acceptable level of safety is granted when dispatching the aircraft without an operative NWS system, the operational burden is significant. For that reason, and to avoid such an event occurring again, the Nose Wheel Steering Item 32-51-01 will be removed from the MMEL. It will no longer be possible to dispatch an aircraft with an inoperative NWS system. The updated Master MEL (MMEL) revision will be available in February 2022. An FOT will also be published to further explain the rationale for removing this MMEL item and to provide appropriate mitigation means in the case of inoperative NWS.

It is not possible to dispatch other Airbus aircraft types with an inoperative NLG due to design differences. The only exception is A300/A310 family aircraft. Based on in-service experience and the design of the A300/A310 NLG, the wheels are not likely to turn at 90°.

### Operational considerations

The A320 FCOM mentions the possibility of having NLG wheels at 90° when both the **WHEEL N/W STRG FAULT** and **L/G SHOCK ABSORBER FAULT** ECAM alerts are triggered and recommends delaying the nosewheel touchdown at landing. ■

## **CONTRIBUTORS:**

### **Hélène CARROLS**

Incident/Accident  
Investigator  
Product Safety

### **LAURENT COUTURET**

Braking and Steering  
Operations Expert  
Customer Support

### **Olivier FERRAN**

Senior Flight Operations  
Engineer  
Customer Support

### **Laurent TIZAC**

Landing Gear  
Mechanical Design  
Expert  
Design Office

**With thanks to Ian  
GOODWIN from  
Product Safety and  
Matthieu BURLOTTE  
from Customer  
Support**

The events in recent years where A320 family aircraft landed with their NLG wheels turned at 90° have different root causes and are not related. There were no serious injuries or fatalities and the damage caused to the nose gears on these aircraft was repairable.

Actions were taken to prevent recurrence of each event. Updated Brake System Control Unit (BSCU) standards were developed and retrofitted. Improved design for the upper support of the NLG shock absorber was deployed on the A320 family fleet.

Following the maintenance and operational procedures remains the strongest safety net to prevent such occurrence. Compliance with the AMM tasks is essential: for shock absorber servicing to avoid an overpressure condition or for aircraft washing to warn against the use of high-pressure hoses.

It is also important for flight crews to remember that they must only perform the authorized reset procedures in flight, which are described in the System Reset table of the A320 QRH/FCOM. If the flight crew performs a reset that is not listed in this table it could lead to unintended and serious incidents.

The latest action taken is to prevent the dispatch of an aircraft with the NWS system inoperative in order to avoid the risk of having the nosewheels at 90°.

